

SECTION IV

2023

ASME Boiler and
Pressure Vessel Code
An International Code

Rules for Construction
of Heating Boilers

Markings such as “ASME,” “ASME Standard,” or any other marking including “ASME,” ASME logos, or the ASME Single Certification Mark shall not be used on any item that is not constructed in accordance with all of the applicable requirements of the Code or Standard. Use of the ASME Single Certification Mark requires formal ASME certification; if no certification program is available, such ASME markings may not be used. (For Certification and Accreditation Programs, see <https://www.asme.org/certification-accreditation>.)

Items produced by parties not formally possessing an ASME Certificate may not be described, either explicitly or implicitly, as ASME certified or approved in any code forms or other document.

AN INTERNATIONAL CODE

2023 ASME Boiler & Pressure Vessel Code

2023 Edition

July 1, 2023

IV RULES FOR CONSTRUCTION OF HEATING BOILERS

ASME Boiler and Pressure Vessel Committee
on Heating Boilers



The American Society of
Mechanical Engineers

Two Park Avenue • New York, NY • 10016 USA

Date of Issuance: July 1, 2023

This international code or standard was developed under procedures accredited as meeting the criteria for American National Standards and it is an American National Standard. The standards committee that approved the code or standard was balanced to ensure that individuals from competent and concerned interests had an opportunity to participate. The proposed code or standard was made available for public review and comment, which provided an opportunity for additional public input from industry, academia, regulatory agencies, and the public-at-large.

ASME does not “approve,” “certify,” “rate,” or “endorse” any item, construction, proprietary device, or activity. ASME does not take any position with respect to the validity of any patent rights asserted in connection with any items mentioned in this document, and does not undertake to insure anyone utilizing a standard against liability for infringement of any applicable letters patent, nor does ASME assume any such liability. Users of a code or standard are expressly advised that determination of the validity of any such patent rights, and the risk of infringement of such rights, is entirely their own responsibility.

Participation by federal agency representatives or persons affiliated with industry is not to be interpreted as government or industry endorsement of this code or standard.

ASME accepts responsibility for only those interpretations of this document issued in accordance with the established ASME procedures and policies, which precludes the issuance of interpretations by individuals.

The endnotes and preamble in this document (if any) are part of this American National Standard.



ASME Collective Membership Mark



ASME Single Certification Mark

“ASME” and the above ASME symbols are registered trademarks of The American Society of Mechanical Engineers.

No part of this document may be reproduced in any form, in an electronic retrieval system or otherwise, without the prior written permission of the publisher.

Library of Congress Catalog Card Number: 56-3934

Adopted by the Council of The American Society of Mechanical Engineers, 1914; latest edition 2023.

The American Society of Mechanical Engineers
Two Park Avenue, New York, NY 10016-5990

Copyright © 2023 by
THE AMERICAN SOCIETY OF MECHANICAL ENGINEERS
All rights reserved
Printed in U.S.A.

TABLE OF CONTENTS

List of Sections		xiii
Foreword		xiv
Statement of Policy on the Use of the ASME Single Certification Mark and Code Authorization in Advertising		xvi
Statement of Policy on the Use of ASME Marking to Identify Manufactured Items		xvi
Personnel		xvii
Correspondence With the Committee		xxxix
Preamble		xli
Summary of Changes		xlii
Cross-Referencing in the ASME BPVC		xlv
PART HG	GENERAL REQUIREMENTS FOR ALL MATERIALS OF CONSTRUCTION .	1
Article 1	Scope and Service Restrictions	1
HG-100	Scope	1
HG-101	Service Restrictions	1
HG-102	Units	1
HG-103	Tolerances	2
Article 2	Material Requirements	3
HG-200	General Material Requirements	3
HG-201	Specific Material Requirements	3
Article 3	Design	4
HG-300	Design Pressure	4
HG-301	Cylindrical Parts Under Internal Pressure	4
HG-305	Formed Heads, Pressure on Concave Side	4
HG-306	Formed Heads, Pressure on Convex Side	5
HG-307	Flat Heads	5
HG-309	Spherically Dished Covers (Bolted Heads)	9
HG-312	Cylindrical Parts Under External Pressure	11
HG-320	Openings in Boilers, General Requirements	14
HG-321	Reinforcement Required for Openings in Shells and Formed Heads	15
HG-323	Flanged-In Openings in Formed Heads	16
HG-325	Reinforcement Required for Openings in Flat Heads	16
HG-326	Limits of Metal Available for Reinforcement	17
HG-327	Strength of Reinforcement	19
HG-328	Reinforcement for Multiple Openings	19
HG-330	Inspection and Access Openings	19
HG-340	Stayed Surfaces	21
HG-341	Staybolts	23
HG-342	Dimensions of Stays	23

HG-343	Dimensions of Diagonal Stays	25
HG-345	Staying of Heads	25
HG-346	Tubesheets With Firetubes Used As Stays	26
HG-350	Ligaments	29
HG-360	Requirements for Tube Holes and Tube Attachments	29
HG-370	External Piping Connections	32
Article 4	Pressure-Relieving Devices	33
Article 4A	Overpressure Protection	34
HG-400A	General Requirements	34
HG-401A	Responsibility	34
HG-402A	Pressure Relief Valve Requirements	34
HG-403A	Heating Surface	36
Article 5	Tests, Inspection, and Marking	37
HG-500	Proof Tests to Establish Design Pressure	37
Article 6	Instruments, Fittings, and Controls	51
HG-600	General	51
HG-601	For Steam Heating Boilers	51
HG-610	For Hot Water Heating or Hot Water Supply Boilers	53
HG-620	For All Boilers	54
HG-630	Electric Wiring	54
HG-640	Controls and Heat Generating Apparatus	54
Article 7	Installation Requirements	56
HG-700	Installation Requirements, All Boilers	56
Article 8	Modular Boilers	65
HG-800	Inspection and Access Openings	65
HG-801	Marking and Certification of Modular Boilers and Use of Manufacturer's Modular Master Data Reports	65
HG-802	Instruments, Fittings, and Controls	65
HG-803	Installation Requirements	66
PART HF	REQUIREMENTS FOR BOILERS CONSTRUCTED OF WROUGHT MATERIALS	68
Article 1	General	68
HF-100	Scope	68
Article 2	Material Requirements	69
HF-200	General Material Requirements	69
HF-201	Plate	69
HF-202	Rods, Bars, and Shapes	69
HF-203	Prefabricated or Preformed Pressure Parts	69
HF-204	Pipe and Tubes	70
HF-205	Material Not Fully Identified	71
HF-206	Recertification of Material Produced to a Specification Not Permitted by This Section	72
HF-207	Austenitic Stainless Steel	72
HF-210	Maintaining Material Identification	72
Article 3	Design Stresses and Minimum Thicknesses	73
HF-300	Maximum Allowable Stress Values	73

HF-301	Minimum Thicknesses	73
HF-302	Basis for Establishing Stress Values in Section II, Part D, Table 6A or Table 6B	73
PART HF — SUBPART HW	REQUIREMENTS FOR BOILERS FABRICATED BY WELDING	74
Article 4	General Requirements	74
HW-400	Scope	74
HW-401	Responsibility of Manufacturer or Contractor	74
Article 5	Material Requirements	75
HW-500	Permissible Materials	75
HW-501	Materials of Different Specifications	75
HW-502	Materials for Small Parts	75
Article 6	Welding Processes and Qualifications	76
HW-600	Welding Processes	76
HW-610	Welding Qualifications	76
HW-611	No Production Work Without Qualifications	76
HW-612	Interchange of Qualifying Tests Among Manufacturers Prohibited	76
HW-613	Maintenance of Records of Qualifications and Identifying Marks	76
Article 7	Design of Weldments	77
HW-700	Design of Welded Joints	77
Article 8	Fabrication Requirements	92
HW-800	Forming Plates	92
HW-801	Base Metal Preparation	92
HW-810	Assembly	92
HW-812	Alignment Tolerance	92
HW-813	Distortion	92
HW-820	Specific Welding Requirements	93
HW-830	Repair of Weld Defects	94
HW-840	Posthydrotest Welding of Nonpressure Parts to Pressure Parts	94
Article 9	Inspection	95
HW-900	Inspection During Fabrication	95
HW-910	Check of Welding Procedure Qualifications	95
HW-911	Check of Welder and Welding Operator Performance Qualifications	95
PART HF — SUBPART HB	REQUIREMENTS FOR BOILERS FABRICATED BY BRAZING	96
Article 10	General Requirements	96
HB-1000	Scope	96
HB-1001	Responsibility of Manufacturer or Contractor	96
Article 11	Material Requirements	97
HB-1100	General	97
HB-1101	Combinations of Dissimilar Materials	97
HB-1102	Brazing Filler Metals	97
HB-1103	Fluxes and Atmospheres	97
Article 12	Brazing Processes, Procedures, and Qualifications	98
HB-1200	Brazing Processes	98
HB-1201	Joint Brazing Procedures	98
HB-1202	Brazing Qualifications and Records	98
Article 13	Design	99

HB-1300	Strength of Brazed Joints	99
HB-1301	Brazed Joint Efficiency Factors	99
HB-1302	Minimum Thickness	99
HB-1303	Permissible Service Temperature	99
HB-1304	Application of Brazing Filler Metal	99
HB-1305	Joint Clearance	99
HB-1306	Openings	100
HB-1307	Brazed Connections	100
Article 14	Fabrication Requirements	101
HB-1400	Cleaning of Surfaces to Be Brazed	101
HB-1401	Postbrazing Operations	101
HB-1402	Repair of Defective Brazing	101
Article 15	Inspection and Marking	102
HB-1500	Inspection	102
PART HC	REQUIREMENTS FOR BOILERS CONSTRUCTED OF CAST IRON	103
Article 1	General	103
HC-100	Scope	103
Article 2	Material Requirements	104
HC-200	General Material Requirements	104
HC-201	Manufacture	104
HC-202	Chemical Composition	104
HC-203	Tensile Strength Classification	104
HC-204	Test Bars	104
HC-205	Selection of Test Bar Size	104
HC-206	Molding and Pouring Test Bars	104
HC-207	Number of Tests	104
HC-208	Tension Test	105
HC-209	Tension Test Procedure	105
HC-210	Tension Retests	105
HC-211	Transverse Test	106
HC-212	Transverse Test Procedure	106
HC-213	Transverse Retests	106
HC-214	Workmanship, Finish, and Repair	107
HC-215	Examinations and Tests	107
HC-216	Test Records	107
Article 3	Design	109
HC-300	Maximum Allowable Stress Values	109
HC-301	Basis for Establishing Stress Values in Table HC-300	109
HC-310	Heads	109
HC-311	Spherically Shaped Covers	109
HC-315	Openings and Reinforcements	111
HC-320	Corners and Fillets	111
HC-325	Washout Openings	111
HC-330	Assembly Method	112
Article 4	Tests	113

HC-400	Tests to Establish Design Pressure	113
Article 5	Quality Control and Inspection	115
HC-501	General	115
HC-502	Outline of Features to Be Included in the Written Description of the Quality Control System	115
HC-510	Examination	116
HC-520	Certificates of Conformance	117
Part HA	REQUIREMENTS FOR BOILERS CONSTRUCTED OF CAST ALUMINUM . .	118
Article 1	General	118
HA-100	Scope	118
Article 2	Material Requirements	119
HA-200	General Material Requirements	119
HA-201	Workmanship, Finish, and Repair	119
HA-202	Examinations and Tests	119
HA-203	Test Records	120
Article 3	Design	121
HA-300	Maximum Allowable Stress Values	121
HA-301	Heads and Spherically Shaped Covers	121
HA-302	Openings and Reinforcements	121
HA-303	Corners and Fillets	121
HA-304	Washout Openings	121
HA-305	Assembly Method	121
Article 4	Tests	122
HA-400	Tests to Establish Design Pressure	122
Article 5	Quality Control and Inspection	125
HA-501	General	125
HA-502	Outline of Features to Be Included in the Written Description of the Quality Control System	125
HA-503	Examination	126
HA-504	Certificates of Conformance	127
Part HLW	REQUIREMENTS FOR POTABLE-WATER HEATERS	128
	Introduction	128
Article 1	General	130
HLW-100	Scope	130
HLW-101	Service Limits	130
HLW-102	Permissible Marking	130
HLW-103	Units	130
Article 2	Material Requirements	132
HLW-200	Lining	132
HLW-201	Primary Pressure Parts Material	133
HLW-202	Acceptance of Unidentified or Small Quantities of Material	133
HLW-203	Miscellaneous Pressure Parts Material	134
HLW-204	Flanges and Pipe Fittings	134
HLW-205	Nonpressure Part Material	134
Article 3	Design	135
HLW-300	Design	135

HLW-301	Basis for Establishing Stress Values in Section II, Part D, Tables 6C and 6D	135
HLW-302	Minimum Thicknesses	135
HLW-303	Shells Under Internal Pressure	135
HLW-305	Blank Unstayed Dished Heads, Pressure on Concave Side	136
HLW-306	Blank Unstayed Dished Heads, Pressure on Convex Side	136
HLW-307	Tubes	136
HLW-308	Openings	136
HLW-309	Tubes Attached by Expanding	137
HLW-310	Storage Tanks	137
Article 4	Design of Weldments	138
HLW-400	Design of Welded Joints	138
Article 5	Tests	153
HLW-500	Tests to Establish Maximum Allowable Working Pressure and Production Line Tests	153
Article 6	Inspection and Marking	156
HLW-600	Inspection and Certification	156
HLW-601	Manufacturer's Data and Partial Data Reports	156
HLW-602	Marking of Water Heaters and Storage Tanks	157
Article 7	Controls	160
HLW-700	Controls	160
Article 8	Installation Requirements	161
HLW-800	Pressure Relief Valves	161
HLW-801	Mounting Pressure Relief Valves	161
HLW-805	Water Supply	162
HLW-809	Provisions for Thermal Expansion in Hot Water Systems	162
HLW-810	Bottom Drain Valve	162
HLW-820	Thermometer	163
Article 9	Modular Water Heater Requirements	165
HLW-900	General	165
HLW-901	Marking	165
HLW-902	Instruments, Fittings, and Controls	165
HLW-903	Installation Requirements	165
Mandatory Appendix 2	Codes, Standards, and Specifications Referenced in Text	167
2-100	Reference Standards	167
2-200	Organizations	167
Mandatory Appendix 3	Adhesive Attachment of Nameplates to Casing	169
3-100	Scope	169
3-101	Nameplate Application Procedure Qualification	169
Mandatory Appendix 4	Guide to Manufacturer's Data Report Forms	170
4-100	Introduction	170
4-200	Manufacturer's Data Report Forms	170
4-300	Certificate of Conformance Forms	170
Mandatory Appendix 5	Vacuum Boilers	198
5-100	Scope	198
5-200	Maximum Pressure and Temperature	198

5-300	Design Parameters	198
5-400	Welding	198
5-500	Alternative to Hydrotest	198
5-600	Instruments, Fittings, and Controls	199
5-700	Inspection Openings	199
Mandatory Appendix 6	Standard Units for Use in Equations	200
Mandatory Appendix 7	Rules for Mass-Production of Heating Boilers	201
7-100	Introduction	201
7-200	Scope	201
7-300	General	201
7-400	Quality Control Procedures	201
7-500	Manufacturer's Data Reports	202
Mandatory Appendix 8	Criteria for Reapplication of a Certification Mark	204
Mandatory Appendix 9	Establishing Governing Code Editions, Addenda, and Cases for Heating Boilers and Replacement Parts	205
9-100	General	205
9-200	Design	205
9-300	Materials	205
9-400	Fabrication	205
9-500	Examination	205
9-600	Inspection	205
9-700	Testing	206
9-800	Overpressure Protection	206
9-900	Field Assembly	206
9-1000	Certification	206
Mandatory Appendix 10	Requirements for Feedwater Economizers	207
10-100	General	207
10-200	Design	207
10-300	Pressure Relief	207
Nonmandatory Appendix A	Estimating Pressure Relief Valve Capacity Requirements	208
A-100	Guide for Estimating Pressure Relief Valve Capacity Based on Heating Surface	208
Nonmandatory Appendix B	Method of Checking Pressure Relief Valve Capacity by Measuring Maximum Amount of Fuel That Can Be Burned	209
B-100	Procedure	209
B-101	Examples	209
B-102	Heats of Combustion of Fuels	210
Nonmandatory Appendix C	Examples of Method of Calculating a Welded Ring Reinforced Furnace	211
C-100	For a Steam or Hot Water Boiler	211
C-101	For a Hot Water Boiler	212
Nonmandatory Appendix D	Examples of Methods of Computation of Openings in Boiler Shells . .	213
D-100	Pad Reinforced Opening	213
D-101	Nozzle Reinforced Opening	213
Nonmandatory Appendix E	Terminology	216
E-100	Terms Relating to Certification	216
E-101	Terms Relating to Design	216
E-102	Terms Relating to Welding	218

Nonmandatory Appendix F	Quality Control System	221
F-100	General	221
F-202	Outline of Features to Be Included in the Written Description of the Quality Control System	221
Nonmandatory Appendix H	List of Abbreviations and Addresses	223
Nonmandatory Appendix K	Guide to Information Appearing on Certificate of Authorization	224
Nonmandatory Appendix M	Guidance for the Use of U.S. Customary and SI Units in the ASME Boiler and Pressure Vessel Code	227
M-100	Use of Units in Equations	227
M-200	Guidelines Used to Develop SI Equivalentents	227
M-300	Soft Conversion Factors	229
Nonmandatory Appendix N	Guide to Manufacturer's Certificate of Conformance for Pressure Relief Valves	230
Nonmandatory Appendix P	Guide to the Relocation of Overpressure Protection Requirements . .	231
 Figures		
HG-307	Some Acceptable Types of Unstayed Flat Heads and Covers	6
HG-309	Spherically Dished Steel Plate Covers With Bolting Flanges	10
HG-312.4	Acceptable Type of Ring-Reinforced Furnace	12
HG-312.7	Connection Between Plain and Corrugated Furnace	13
HG-312.8	Acceptable Type of Semicircular Furnace Reinforcement	14
HG-321	Chart for Determining Values of F	16
HG-326.1	Some Representative Configurations Describing the Reinforcement Dimension, t_e , and the Finished Opening Dimension, d	18
HG-326.2	Nomenclature and Formulas for Reinforced Openings	20
HG-340.1	Pitch of Staybolts Adjacent to Upper Corners of Fireboxes	22
HG-340.2	Acceptable Proportions for Ends of Through-Stays	22
HG-340.3	Examples of Acceptable Corner Welds for Pressures Not Over 30 psi . . .	23
HG-343	Details of Installation of Diagonal Stays	26
HG-345.1(a)	Sketch Showing Application of HG-345.1 to the Staying of Boilers	27
HG-345.1(b)	Sketch Showing Application of HG-345.1 to the Staying of Boilers	28
HG-350.1	Example of Tube Spacing With Pitch of Holes Equal in Every Row	29
HG-350.2	Example of Tube Spacing With Pitch of Holes Unequal in Every Second Row	30
HG-350.3	Example of Tube Spacing With Pitch of Holes Varying in Every Second and Third Row	31
HG-350.4	Example of Tube Spacing With Tube Holes on Diagonal Lines	31
HG-530.1	Official Certification Mark to Denote the American Society of Mechanical Engineers' Standard	44
HG-530.2	Steam and Water Boilers Form of Marking on Completed Boilers or Their Nameplates (Not Applicable for Boilers Constructed Primarily of Cast Iron)	45
HG-530.3	Boilers Suitable for Water Only Form of Marking on Completed Boilers or Their Nameplates (Not Applicable for Boilers Constructed Primarily of Cast Iron)	45
HG-530.4	Steam and Water Boilers Form of Data Cast or Marked on Cast Iron Boiler Sections	46
HG-530.5	Boilers Suitable for Water Only Form of Data Cast or Marked on Cast Iron Boiler Sections	46

HG-530.6	Boilers Suitable for Water Only Form of Data Cast or Marked on Cast Aluminum Boiler Sections	47
HG-530.7	Steam and Water Boilers Form of Marking on Completed Cast Iron Boilers or Their Nameplates	47
HG-530.8	Boilers Suitable for Water Only Form of Marking on Completed Cast Iron or Cast Aluminum Boilers or Their Nameplates	47
HG-531.1	Form of Marking on Part or Accessory — H Designator	48
HG-531.2	Form of Marking on Part or Accessory — PRT IV Designator	49
HG-703.1(a)	Steam Boilers in Battery — Pumped Return — Acceptable Piping Installation	58
HG-703.1(b)	Steam Boilers in Battery — Gravity Return — Acceptable Piping Installation	59
HG-703.2	Hot Water Boilers in Battery — Acceptable Piping Installation	60
HG-725(a)	Spacing and Weld Details for Supporting Lugs in Pairs on Horizontal-Return Tubular Boiler	63
HG-725(b)	Welded Bracket Connection for Horizontal-Return Tubular Boiler	63
HW-701.1	Butt Welding of Plates of Unequal Thickness	78
HW-701.3	Some Forms of Attachments of Pressure Parts to Flat Plates to Form a Corner Joint (Tee Joint)	79
HW-710.4(a)	Some Acceptable Types of Diagonal Stays for Installation by Welding . . .	80
HW-710.4(b)	Unacceptable Types of Diagonal Stays for Installation by Welding	80
HW-715.1	Heads Attached to Shells	83
HW-731	Some Acceptable Types of Welds for Fittings, Nozzles, and Other Connections to Shells, Drums, and Headers	85
HW-740	Three-Ply Joint Assemblies	87
HW-745	Two-Ply Joint Assemblies	90
HC-204.1	Dimensions of Tensile Test Specimen	105
HC-205.1	Cast Test Bars	106
HC-311	Spherically Shaped Covers With Bolting Flanges	110
HLW-401.1	Butt Welding of Plates of Unequal Thickness	138
HLW-401.2	Typical Corner Joints	139
HLW-411	Typical Water Heater Welded Joints	141
HLW-413	Tubes Attached by Welding	143
HLW-415	Heads Attached to Shells	144
HLW-431.1	Some Acceptable Types of Welds for Fittings, Nozzles, and Other Connections to Shells and Head	146
HLW-431.5	Some Acceptable Types of Welds for Fittings, Nozzles, and Other Connections to Shells and Head	147
HLW-432.1	Some Acceptable Types of Brazed Fittings, Nozzles, and Other Connections to Copper-Lined Shells and Heads	150
HLW-602.1	Official Symbol to Denote The American Society of Mechanical Engineers' Standard	158
HLW-602.2	Form of Marking on Completed Water Heaters	158
HLW-809.1	A Typical Acceptable Piping Installation for Storage Water Heaters in Battery	163
HLW-809.2	A Typical Acceptable Piping Installation for Flow Through Water Heater With Provisions for Piping Expansion	164
D-100	Computation of Typical Pad Reinforcement	213
D-101	Computation of a Typical Nozzle Fitting	214
K-1	Sample Certificate of Authorization	226

Tables

HG-321	Values of Spherical Radius Factor K_1	16
HG-340	Allowable Pitch of Stays, in. (mm) (Limited by HG-340.3)	24
HG-360	Permitted O-Ring Materials	31
HG-370	Minimum Thickness of Material for Threaded Connections to Boilers	32
HG-709.2	Expansion Tank Capacities for Forced Hot Water Systems	61
HG-715	Size of Bottom Blowoff Piping, Valves, and Cocks	62
HW-713	Firetube Extension Through Tubesheets for Welded Construction	82
HB-1305	Recommended Joint Clearances at Brazing Temperature	100
HC-212	Correction Factors for Transverse Test Bars	107
HC-214	Pipe Plug Size for Minimum Wall Thickness	108
HC-300	Maximum Allowable Stress Values in Tension for Cast Iron, ksi (MPa)	109
HLW-401.3-1	Alignment Tolerance	139
HLW-809.1	Expansion Tank Capacities for a Water Heater	164
2-100	Codes, Standards, and Specifications Referenced in Text	168
4-1	Guide for the Preparation of Section IV Manufacturer’s Data Report Forms	171
6-1	Standard Units for Use in Equations	200
A-100	Guide for Estimating Steaming Capacity Based on Heating Surface	208

Forms

H-1	Manufacturer’s Modular Master Data Report for Modular Boilers or Modular Water Heaters	174
H-2	Manufacturer’s Data Report for All Types of Boilers Except Watertube and Those Made of Cast Iron or Cast Aluminum	176
H-3	Manufacturer’s Data Report for Watertube Boilers and Economizers	178
H-4	Manufacturer’s Partial Data Report	180
H-5	Manufacturer’s Master Data Report for Boilers Constructed From Cast Iron	182
H-5A	Manufacturer’s Master Data Report for Boilers Constructed From Cast Aluminum	184
H-6	Manufacturer’s Data Report Supplementary Sheet	186
HC-1	Manufacturer’s Material Certificate of Conformance for Cast Iron Boiler Sections	187
HC-2	Manufacturer’s Material Certificate of Conformance for Hydrostatic Testing of Cast Iron Boiler Sections	188
HC-3	Manufacturer’s Report for the Application of Nameplates on Cast Iron Boilers	189
HA-1	Manufacturer’s Material Certificate of Conformance for Cast Aluminum Boiler Sections	190
HA-2	Manufacturer’s Material Certificate of Conformance for Hydrostatic and Pneumatic Testing of Cast Aluminum Boiler Sections	191
HA-3	Manufacturer’s Report for the Application of Nameplates on Cast Aluminum Boilers	192
HLW-6	Manufacturer’s Data Report for Water Heaters or Storage Tanks	193
HLW-7	Manufacturer’s Partial Data Report for Water Heaters and Storage Tanks	195
HLW-8	Manufacturer’s Master Data Proof Test Report for Water Heaters or Storage Tanks	197

Endnotes

.	232
-----------	-----

LIST OF SECTIONS

(23)

SECTIONS

- I Rules for Construction of Power Boilers
- II Materials
 - Part A — Ferrous Material Specifications
 - Part B — Nonferrous Material Specifications
 - Part C — Specifications for Welding Rods, Electrodes, and Filler Metals
 - Part D — Properties (Customary)
 - Part D — Properties (Metric)
- III Rules for Construction of Nuclear Facility Components
 - Subsection NCA — General Requirements for Division 1 and Division 2
 - Appendices
 - Division 1
 - Subsection NB — Class 1 Components
 - Subsection NCD — Class 2 and Class 3 Components
 - Subsection NE — Class MC Components
 - Subsection NF — Supports
 - Subsection NG — Core Support Structures
 - Division 2 — Code for Concrete Containments
 - Division 3 — Containment Systems for Transportation and Storage of Spent Nuclear Fuel and High-Level Radioactive Material
 - Division 4 — Fusion Energy Devices
 - Division 5 — High Temperature Reactors
- IV Rules for Construction of Heating Boilers
- V Nondestructive Examination
- VI Recommended Rules for the Care and Operation of Heating Boilers
- VII Recommended Guidelines for the Care of Power Boilers
- VIII Rules for Construction of Pressure Vessels
 - Division 1
 - Division 2 — Alternative Rules
 - Division 3 — Alternative Rules for Construction of High Pressure Vessels
- IX Welding, Brazing, and Fusing Qualifications
- X Fiber-Reinforced Plastic Pressure Vessels
- XI Rules for Inservice Inspection of Nuclear Reactor Facility Components
 - Division 1 — Rules for Inspection and Testing of Components of Light-Water-Cooled Plants
 - Division 2 — Requirements for Reliability and Integrity Management (RIM) Programs for Nuclear Reactor Facilities
- XII Rules for Construction and Continued Service of Transport Tanks
- XIII Rules for Overpressure Protection

FOREWORD*

In 1911, The American Society of Mechanical Engineers established the Boiler and Pressure Vessel Committee to formulate standard rules for the construction of steam boilers and other pressure vessels. In 2009, the Boiler and Pressure Vessel Committee was superseded by the following committees:

- (a) Committee on Power Boilers (I)
- (b) Committee on Materials (II)
- (c) Committee on Construction of Nuclear Facility Components (III)
- (d) Committee on Heating Boilers (IV)
- (e) Committee on Nondestructive Examination (V)
- (f) Committee on Pressure Vessels (VIII)
- (g) Committee on Welding, Brazing, and Fusing (IX)
- (h) Committee on Fiber-Reinforced Plastic Pressure Vessels (X)
- (i) Committee on Nuclear Inservice Inspection (XI)
- (j) Committee on Transport Tanks (XII)
- (k) Committee on Overpressure Protection (XIII)
- (l) Technical Oversight Management Committee (TOMC)

Where reference is made to “the Committee” in this Foreword, each of these committees is included individually and collectively.

The Committee’s function is to establish rules of safety relating to pressure integrity, which govern the construction** of boilers, pressure vessels, transport tanks, and nuclear components, and the inservice inspection of nuclear components and transport tanks. The Committee also interprets these rules when questions arise regarding their intent. The technical consistency of the Sections of the Code and coordination of standards development activities of the Committees is supported and guided by the Technical Oversight Management Committee. This Code does not address other safety issues relating to the construction of boilers, pressure vessels, transport tanks, or nuclear components, or the inservice inspection of nuclear components or transport tanks. Users of the Code should refer to the pertinent codes, standards, laws, regulations, or other relevant documents for safety issues other than those relating to pressure integrity. Except for Sections XI and XII, and with a few other exceptions, the rules do not, of practical necessity, reflect the likelihood and consequences of deterioration in service related to specific service fluids or external operating environments. In formulating the rules, the Committee considers the needs of users, manufacturers, and inspectors of pressure vessels. The objective of the rules is to afford reasonably certain protection of life and property, and to provide a margin for deterioration in service to give a reasonably long, safe period of usefulness. Advancements in design and materials and evidence of experience have been recognized.

This Code contains mandatory requirements, specific prohibitions, and nonmandatory guidance for construction activities and inservice inspection and testing activities. The Code does not address all aspects of these activities and those aspects that are not specifically addressed should not be considered prohibited. The Code is not a handbook and cannot replace education, experience, and the use of engineering judgment. The phrase *engineering judgment* refers to technical judgments made by knowledgeable engineers experienced in the application of the Code. Engineering judgments must be consistent with Code philosophy, and such judgments must never be used to overrule mandatory requirements or specific prohibitions of the Code.

The Committee recognizes that tools and techniques used for design and analysis change as technology progresses and expects engineers to use good judgment in the application of these tools. The designer is responsible for complying with Code rules and demonstrating compliance with Code equations when such equations are mandatory. The Code neither requires nor prohibits the use of computers for the design or analysis of components constructed to the requirements of the Code. However, designers and engineers using computer programs for design or analysis are cautioned that they are responsible for all technical assumptions inherent in the programs they use and the application of these programs to their design.

* The information contained in this Foreword is not part of this American National Standard (ANS) and has not been processed in accordance with ANSI’s requirements for an ANS. Therefore, this Foreword may contain material that has not been subjected to public review or a consensus process. In addition, it does not contain requirements necessary for conformance to the Code.

** *Construction*, as used in this Foreword, is an all-inclusive term comprising materials, design, fabrication, examination, inspection, testing, certification, and overpressure protection.

The rules established by the Committee are not to be interpreted as approving, recommending, or endorsing any proprietary or specific design, or as limiting in any way the manufacturer's freedom to choose any method of design or any form of construction that conforms to the Code rules.

The Committee meets regularly to consider revisions of the rules, new rules as dictated by technological development, Code Cases, and requests for interpretations. Only the Committee has the authority to provide official interpretations of this Code. Requests for revisions, new rules, Code Cases, or interpretations shall be addressed to the Secretary in writing and shall give full particulars in order to receive consideration and action (see Submittal of Technical Inquiries to the Boiler and Pressure Vessel Standards Committees). Proposed revisions to the Code resulting from inquiries will be presented to the Committee for appropriate action. The action of the Committee becomes effective only after confirmation by ballot of the Committee and approval by ASME. Proposed revisions to the Code approved by the Committee are submitted to the American National Standards Institute (ANSI) and published at <http://go.asme.org/BPVCPublicReview> to invite comments from all interested persons. After public review and final approval by ASME, revisions are published at regular intervals in Editions of the Code.

The Committee does not rule on whether a component shall or shall not be constructed to the provisions of the Code. The scope of each Section has been established to identify the components and parameters considered by the Committee in formulating the Code rules.

Questions or issues regarding compliance of a specific component with the Code rules are to be directed to the ASME Certificate Holder (Manufacturer). Inquiries concerning the interpretation of the Code are to be directed to the Committee. ASME is to be notified should questions arise concerning improper use of the ASME Single Certification Mark.

When required by context in this Section, the singular shall be interpreted as the plural, and vice versa, and the feminine, masculine, or neuter gender shall be treated as such other gender as appropriate.

The words "shall," "should," and "may" are used in this Standard as follows:

- *Shall* is used to denote a requirement.
- *Should* is used to denote a recommendation.
- *May* is used to denote permission, neither a requirement nor a recommendation.

STATEMENT OF POLICY ON THE USE OF THE ASME SINGLE CERTIFICATION MARK AND CODE AUTHORIZATION IN ADVERTISING

ASME has established procedures to authorize qualified organizations to perform various activities in accordance with the requirements of the ASME Boiler and Pressure Vessel Code. It is the aim of the Society to provide recognition of organizations so authorized. An organization holding authorization to perform various activities in accordance with the requirements of the Code may state this capability in its advertising literature.

Organizations that are authorized to use the ASME Single Certification Mark for marking items or constructions that have been constructed and inspected in compliance with the ASME Boiler and Pressure Vessel Code are issued Certificates of Authorization. It is the aim of the Society to maintain the standing of the ASME Single Certification Mark for the benefit of the users, the enforcement jurisdictions, and the holders of the ASME Single Certification Mark who comply with all requirements.

Based on these objectives, the following policy has been established on the usage in advertising of facsimiles of the ASME Single Certification Mark, Certificates of Authorization, and reference to Code construction. The American Society of Mechanical Engineers does not “approve,” “certify,” “rate,” or “endorse” any item, construction, or activity and there shall be no statements or implications that might so indicate. An organization holding the ASME Single Certification Mark and/or a Certificate of Authorization may state in advertising literature that items, constructions, or activities “are built (produced or performed) or activities conducted in accordance with the requirements of the ASME Boiler and Pressure Vessel Code,” or “meet the requirements of the ASME Boiler and Pressure Vessel Code.” An ASME corporate logo shall not be used by any organization other than ASME.

The ASME Single Certification Mark shall be used only for stamping and nameplates as specifically provided in the Code. However, facsimiles may be used for the purpose of fostering the use of such construction. Such usage may be by an association or a society, or by a holder of the ASME Single Certification Mark who may also use the facsimile in advertising to show that clearly specified items will carry the ASME Single Certification Mark.

STATEMENT OF POLICY ON THE USE OF ASME MARKING TO IDENTIFY MANUFACTURED ITEMS

The ASME Boiler and Pressure Vessel Code provides rules for the construction of boilers, pressure vessels, and nuclear components. This includes requirements for materials, design, fabrication, examination, inspection, and stamping. Items constructed in accordance with all of the applicable rules of the Code are identified with the ASME Single Certification Mark described in the governing Section of the Code.

Markings such as “ASME,” “ASME Standard,” or any other marking including “ASME” or the ASME Single Certification Mark shall not be used on any item that is not constructed in accordance with all of the applicable requirements of the Code.

Items shall not be described on ASME Data Report Forms nor on similar forms referring to ASME that tend to imply that all Code requirements have been met when, in fact, they have not been. Data Report Forms covering items not fully complying with ASME requirements should not refer to ASME or they should clearly identify all exceptions to the ASME requirements.

PERSONNEL

ASME Boiler and Pressure Vessel Standards Committees, Subgroups, and Working Groups

(23)

January 1, 2023

TECHNICAL OVERSIGHT MANAGEMENT COMMITTEE (TOMC)

R. E. McLaughlin, <i>Chair</i>	W. M. Lundy
N. A. Finney, <i>Vice Chair</i>	D. I. Morris
S. J. Rossi, <i>Staff Secretary</i>	T. P. Pastor
G. Aurioles, Sr.	M. D. Rana
R. W. Barnes	S. C. Roberts
T. L. Bedeaux	F. J. Schaaf, Jr.
C. Brown	G. Scribner
D. B. DeMichael	W. J. Sperko
R. P. Deubler	D. Srnec
J. G. Feldstein	R. W. Swayne
G. W. Galanes	J. Vattappilly
J. A. Hall	M. Wadkinson
T. E. Hansen	B. K. Nutter, <i>Ex-Officio Member</i>
G. W. Hembree	M. J. Pischke, <i>Ex-Officio Member</i>
R. B. Keating	J. F. Henry, <i>Honorary Member</i>
B. Linnemann	

Subgroup on Research and Development (TOMC)

S. C. Roberts, <i>Chair</i>	R. B. Keating
S. J. Rossi, <i>Staff Secretary</i>	R. E. McLaughlin
R. W. Barnes	T. P. Pastor
N. A. Finney	D. Andrei, <i>Contributing Member</i>
W. Hoffelner	

Subgroup on Strategic Initiatives (TOMC)

N. A. Finney, <i>Chair</i>	M. H. Jawad
S. J. Rossi, <i>Staff Secretary</i>	R. B. Keating
R. W. Barnes	R. E. McLaughlin
T. L. Bedeaux	T. P. Pastor
G. W. Hembree	S. C. Roberts

Task Group on Remote Inspection and Examination (SI-TOMC)

S. C. Roberts, <i>Chair</i>	M. Tannenbaum
P. J. Coco	J. Cameron, <i>Alternate</i>
N. A. Finney	A. Byk, <i>Contributing Member</i>
S. A. Marks	J. Pang, <i>Contributing Member</i>
R. Rockwood	S. J. Rossi, <i>Contributing Member</i>
C. Stevens	C. A. Sanna, <i>Contributing Member</i>

Special Working Group on High Temperature Technology (TOMC)

D. Dewees, <i>Chair</i>	B. F. Hantz
F. W. Brust	R. I. Jetter
T. D. Burchell	P. Smith
P. R. Donavin	

ADMINISTRATIVE COMMITTEE

R. E. McLaughlin, <i>Chair</i>	M. J. Pischke
N. A. Finney, <i>Vice Chair</i>	M. D. Rana
S. J. Rossi, <i>Staff Secretary</i>	S. C. Roberts
J. Cameron	R. R. Stevenson
R. B. Keating	R. W. Swayne
B. Linnemann	M. Wadkinson
B. K. Nutter	

MARINE CONFERENCE GROUP

J. Oh, <i>Staff Secretary</i>	H. N. Patel
J. G. Hungerbuhler, Jr.	N. Prokopuk
G. Nair	J. D. Reynolds

CONFERENCE COMMITTEE

R. D. Troutt — Texas, <i>Chair</i>	J. LeSage, Jr. — Louisiana
J. T. Amato — Ohio, <i>Secretary</i>	A. M. Lorimor — South Dakota
W. Anderson — Mississippi	M. Mailman — Northwest Territories, Canada
R. Becker — Colorado	W. McGivney — City of New York, New York
T. D. Boggs — Missouri	S. F. Noonan — Maryland
R. A. Boillard — Indiana	C. L. O'Guin — Tennessee
D. P. Brockerville — Newfoundland and Labrador, Canada	B. S. Oliver — New Hampshire
R. J. Bunte — Iowa	J. L. Oliver — Nevada
J. H. Burpee — Maine	P. B. Polick — Illinois
M. Carlson — Washington	J. F. Porcella — West Virginia
T. G. Clark — Oregon	B. Ricks — Montana
B. J. Crawford — Georgia	W. J. Ross — Pennsylvania
E. L. Creaser — New Brunswick, Canada	M. H. Sansone — New York
J. J. Dacanay — Hawaii	T. S. Seime — North Dakota
R. DeLury — Manitoba, Canada	C. S. Selinger — Saskatchewan, Canada
A. Denham — Michigan	J. E. Sharier — Ohio
C. Dinic — Ontario, Canada	R. Spiker — North Carolina
D. A. Ehler — Nova Scotia, Canada	D. Srnec — Alberta, Canada
S. D. Frazier — Washington	D. J. Stenrose — Michigan
T. J. Granneman II — Oklahoma	R. J. Stimson II — Kansas
S. Harder — Arizona	R. K. Sturm — Utah
M. L. Jordan — Kentucky	D. K. Sullivan — Arkansas
R. Kamboj — British Columbia, Canada	J. Taveras — Rhode Island
E. Kawa — Massachusetts	G. Teel — California
A. Khssassi — Quebec, Canada	D. M. Warburton — Florida
D. Kinney — North Carolina	M. Washington — New Jersey
K. S. Lane — Alaska	E. Wiggins — Alabama

INTERNATIONAL INTEREST REVIEW GROUP

V. Felix
 Y.-G. Kim
 S. H. Leong
 W. Lin
 O. F. Manafa

C. Minu
 Y.-W. Park
 A. R. Reynaga Nogales
 P. Williamson

COMMITTEE ON POWER BOILERS (BPV I)

R. E. McLaughlin, *Chair*
 E. M. Ortman, *Vice Chair*
 U. D'Urso, *Staff Secretary*
 D. I. Anderson
 J. L. Arnold
 K. K. Coleman
 J. G. Feldstein
 S. Fincher
 G. W. Galanes
 T. E. Hansen
 J. S. Hunter
 M. Ishikawa
 M. Lemmons
 L. Moedinger
 Y. Oishi
 M. Ortolani
 A. Spangenberg
 D. E. Tompkins
 D. E. Tuttle

J. Vattappilly
 M. Wadkinson
 R. V. Wielgoszinski
 F. Zeller
 H. Michael, *Delegate*
 D. L. Berger, *Honorary Member*
 P. D. Edwards, *Honorary Member*
 D. N. French, *Honorary Member*
 J. Hainsworth, *Honorary Member*
 J. F. Henry, *Honorary Member*
 W. L. Lowry, *Honorary Member*
 J. R. MacKay, *Honorary Member*
 P. A. Molvie, *Honorary Member*
 J. T. Pillow, *Honorary Member*
 B. W. Roberts, *Honorary Member*
 R. D. Schueler, Jr., *Honorary Member*
 J. M. Tanzosh, *Honorary Member*
 R. L. Williams, *Honorary Member*
 L. W. Yoder, *Honorary Member*

Executive Committee (BPV I)

E. M. Ortman, *Chair*
 R. E. McLaughlin, *Vice Chair*
 D. I. Anderson
 J. L. Arnold
 J. R. Braun
 K. K. Coleman
 H. Dalal
 T. Dhanraj

U. D'Urso
 P. F. Gilston
 K. Hayes
 P. Jennings
 A. Spangenberg
 D. E. Tompkins
 M. Wadkinson

Subgroup on Design (BPV I)

D. I. Anderson, *Chair*
 L. S. Tsai, *Secretary*
 P. Becker
 L. Krupp
 C. T. McDaris

N. S. Ranck
 J. Vattappilly
 M. Wadkinson
 D. Dewees, *Contributing Member*
 J. P. Glaspie, *Contributing Member*

Subgroup on Fabrication and Examination (BPV I)

J. L. Arnold, *Chair*
 P. F. Gilston, *Vice Chair*
 P. Becker, *Secretary*
 K. K. Coleman
 S. Fincher
 G. W. Galanes
 T. E. Hansen

P. Jennings
 M. Lewis
 C. T. McDaris
 R. E. McLaughlin
 R. J. Newell
 Y. Oishi
 R. V. Wielgoszinski

Subgroup on General Requirements and Piping (BPV I)

D. E. Tompkins, *Chair*
 M. Wadkinson, *Vice Chair*
 M. Lemmons, *Secretary*
 R. Antoniuk
 T. E. Hansen
 M. Ishikawa
 R. E. McLaughlin
 L. Moedinger

B. J. Mollitor
 Y. Oishi
 E. M. Ortman
 D. E. Tuttle
 J. Vattappilly
 R. V. Wielgoszinski
 W. L. Lowry, *Contributing Member*

Subgroup on Locomotive Boilers (BPV I)

J. R. Braun, *Chair*
 S. M. Butler, *Secretary*
 G. W. Galanes
 D. W. Griner
 M. A. Janssen

S. A. Lee
 L. Moedinger
 G. M. Ray
 M. W. Westland

Subgroup on Materials (BPV I)

K. K. Coleman, *Chair*
 K. Hayes, *Vice Chair*
 M. Lewis, *Secretary*
 S. H. Bowes
 G. W. Galanes
 P. F. Gilston
 J. S. Hunter
 E. Liebl

F. Masuyama
 L. S. Nicol
 M. Ortolani
 D. W. Raho
 F. Zeller
 B. W. Roberts, *Contributing Member*
 J. M. Tanzosh, *Contributing Member*

Subgroup on Solar Boilers (BPV I)

P. Jennings, *Chair*
 R. E. Hearne, *Secretary*
 S. Fincher

J. S. Hunter
 P. Swarnkar

Task Group on Modernization (BPV I)

D. I. Anderson, *Chair*
 U. D'Urso, *Staff Secretary*
 J. L. Arnold
 D. Dewees
 G. W. Galanes
 J. P. Glaspie

T. E. Hansen
 R. E. McLaughlin
 E. M. Ortman
 D. E. Tuttle
 J. Vattappilly

Germany International Working Group (BPV I)

A. Spangenberg, *Chair*
 P. Chavdarov, *Secretary*
 B. Daume
 J. Fleischfresser
 C. Jaekel
 R. Kauer
 D. Koelbl
 S. Krebs
 T. Ludwig

R. A. Meyers
 H. Michael
 F. Miunske
 M. Sykora
 R. Helmholdt, *Contributing Member*
 J. Henrichsmeyer, *Contributing Member*
 B. Müller, *Contributing Member*

India International Working Group (BPV I)

H. Dalal, <i>Chair</i>	S. Purkait
T. Dhanraj, <i>Vice Chair</i>	M. G. Rao
K. Thanupillai, <i>Secretary</i>	G. U. Shanker
P. Brahma	D. K. Shrivastava
S. Chakrabarti	K. Singha
A. Hantodkar	R. Sundararaj
A. J. Patil	S. Venkataramana

Subgroup on International Material Specifications (BPV II)

M. Ishikawa, <i>Chair</i>	F. Zeller
P. Chavdarov, <i>Vice Chair</i>	C. Zhou
A. Chaudouet	O. Oldani, <i>Delegate</i>
H. Chen	H. Lorenz, <i>Contributing Member</i>
A. F. Garbolevsky	T. F. Miskell, <i>Contributing Member</i>
D. O. Henry	E. Uptis, <i>Contributing Member</i>
W. M. Lundy	

COMMITTEE ON MATERIALS (BPV II)

J. Cameron, <i>Chair</i>	L. S. Nicol
G. W. Galanes, <i>Vice Chair</i>	M. Ortolani
C. E. Rodrigues, <i>Staff Secretary</i>	D. W. Raho
A. Appleton	W. Ren
P. Chavdarov	E. Shapiro
K. K. Coleman	R. C. Sutherlin
D. W. Gandy	F. Zeller
J. F. Grubb	O. Oldani, <i>Delegate</i>
J. A. Hall	A. Chaudouet, <i>Contributing Member</i>
D. O. Henry	J. D. Fritz, <i>Contributing Member</i>
K. M. Hottle	W. Hoffelner, <i>Contributing Member</i>
M. Ishikawa	K. E. Orié, <i>Contributing Member</i>
K. Kimura	D. T. Peters, <i>Contributing Member</i>
M. Kowalczyk	B. W. Roberts, <i>Contributing Member</i>
D. L. Kurle	J. M. Tanzosh, <i>Contributing Member</i>
F. Masuyama	E. Uptis, <i>Contributing Member</i>
S. Neilsen	R. G. Young, <i>Contributing Member</i>

Subgroup on Nonferrous Alloys (BPV II)

E. Shapiro, <i>Chair</i>	J. A. McMaster
W. MacDonald, <i>Vice Chair</i>	D. W. Raho
J. Robertson, <i>Secretary</i>	W. Ren
R. M. Beldyk	R. C. Sutherlin
J. M. Downs	R. Wright
J. F. Grubb	S. Yem
J. A. Hall	D. B. Denis, <i>Contributing Member</i>
D. Maitra	D. T. Peters, <i>Contributing Member</i>

Subgroup on Physical Properties (BPV II)

P. K. Rai, <i>Chair</i>	R. D. Jones
S. Neilsen, <i>Vice Chair</i>	P. K. Lam
G. Aurioles, Sr.	D. W. Raho
D. Chandiramani	E. Shapiro
P. Chavdarov	D. K. Verma
H. Eshraghi	S. Yem
J. F. Grubb	D. B. Denis, <i>Contributing Member</i>
B. F. Hantz	

Executive Committee (BPV II)

J. Cameron, <i>Chair</i>	W. Hoffelner
C. E. Rodrigues, <i>Staff Secretary</i>	M. Ishikawa
A. Appleton	M. Ortolani
K. K. Coleman	P. K. Rai
G. W. Galanes	J. Robertson
J. F. Grubb	E. Shapiro
S. Guzey	

Subgroup on Strength, Ferrous Alloys (BPV II)

M. Ortolani, <i>Chair</i>	M. Osterfoss
L. S. Nicol, <i>Secretary</i>	D. W. Raho
G. W. Galanes	S. Rosinski
J. A. Hall	M. Ueyama
M. Ishikawa	F. Zeller
S. W. Knowles	F. Abe, <i>Contributing Member</i>
F. Masuyama	R. G. Young, <i>Contributing Member</i>

Subgroup on External Pressure (BPV II)

S. Guzey, <i>Chair</i>	M. H. Jawad
E. Alexis, <i>Vice Chair</i>	S. Krishnamurthy
J. A. A. Morrow, <i>Secretary</i>	D. L. Kurle
L. F. Campbell	R. W. Mikitka
H. Chen	P. K. Rai
D. S. Griffin	M. Wadkinson
J. F. Grubb	

Subgroup on Strength of Weldments (BPV II & BPV IX)

K. K. Coleman, <i>Chair</i>	J. Penso
K. L. Hayes, <i>Vice Chair</i>	D. W. Raho
S. H. Bowes, <i>Secretary</i>	W. J. Sperko
M. Denault	J. P. Swezy, Jr.
G. W. Galanes	M. Ueyama
D. W. Gandy	P. D. Flenner, <i>Contributing Member</i>
M. Ghahremani	B. W. Roberts, <i>Contributing Member</i>
W. F. Newell, Jr.	

Subgroup on Ferrous Specifications (BPV II)

A. Appleton, <i>Chair</i>	S. G. Lee
K. M. Hottle, <i>Vice Chair</i>	W. C. Mack
C. Hyde, <i>Secretary</i>	J. Nickel
D. Amire-Brahimi	K. E. Orié
G. Cuccio	D. Poweleit
O. Elkadim	E. Uptis
D. Fialkowski	L. Watzke
J. F. Grubb	J. D. Fritz, <i>Contributing Member</i>
D. S. Janikowski	C. Meloy, <i>Contributing Member</i>
Y.-J. Kim	

Working Group on Materials Database (BPV II)

W. Hoffelner, <i>Chair</i>	J. Cameron, <i>Contributing Member</i>
C. E. Rodrigues, <i>Staff Secretary</i>	J. F. Grubb, <i>Contributing Member</i>
F. Abe	D. T. Peters, <i>Contributing Member</i>
W. MacDonald	W. Ren, <i>Contributing Member</i>
R. C. Sutherlin	B. W. Roberts, <i>Contributing Member</i>
D. Andrei, <i>Contributing Member</i>	E. Shapiro, <i>Contributing Member</i>
J. L. Arnold, <i>Contributing Member</i>	

Working Group on Creep Strength Enhanced Ferritic Steels (BPV II)

M. Ortolani, <i>Chair</i>	T. Melfi
G. W. Galanes, <i>Vice Chair</i>	W. F. Newell, Jr.
P. Becker, <i>Secretary</i>	J. J. Sanchez-Hanton
S. H. Bowes	J. A. Siefert
K. K. Coleman	W. J. Sperko
K. Kimura	F. Zeller
M. Lang	F. Abe, <i>Contributing Member</i>
S. Luke	P. D. Flenner, <i>Contributing Member</i>
F. Masuyama	J. M. Tanzosh, <i>Contributing Member</i>

Working Group on Data Analysis (BPV II)

J. F. Grubb, <i>Chair</i>	M. J. Swindeman
W. Ren, <i>Vice Chair</i>	F. Abe, <i>Contributing Member</i>
K. Kimura	W. Hoffelner, <i>Contributing Member</i>
F. Masuyama	W. C. Mack, <i>Contributing Member</i>
S. Neilsen	D. T. Peters, <i>Contributing Member</i>
M. Ortolani	B. W. Roberts, <i>Contributing Member</i>

China International Working Group (BPV II)

T. Xu, <i>Secretary</i>	S. Tan
W. Cai	C. Wang
W. Fang	Jinguang Wang
Q. C. Feng	Jiongxian Wang
S. Huo	Q.-J. Wang
F. Kong	X. Wang
H. Leng	H.-C. Yang
Hli Li	J. Yang
Hongbin Li	L. Yin
J. Li	H. Zhang
S. Liu	X.-H. Zhang
Z. Rongcan	Y. Zhang

COMMITTEE ON CONSTRUCTION OF NUCLEAR FACILITY COMPONENTS (BPV III)

R. B. Keating, <i>Chair</i>	K. Matsunaga
T. M. Adams, <i>Vice Chair</i>	B. McGlone
D. E. Matthews, <i>Vice Chair</i>	S. McKillop
A. Maslowski, <i>Staff Secretary</i>	J. McLean
A. Appleton	J. C. Minichiello
S. Asada	M. N. Mitchell
R. W. Barnes	T. Nagata
W. H. Borter	J. B. Ossmann
M. E. Cohen	S. Pellet
R. P. Deubler	E. L. Pleins
P. R. Donavin	T.-L. Sham
A. C. Eberhardt	W. J. Sperko
J. V. Gardiner	W. Windes
J. Grimm	C. Basavaraju, <i>Alternate</i>
S. Hunter	C. T. Smith, <i>Contributing Member</i>
R. M. Jessee	W. K. Sowder, Jr., <i>Contributing Member</i>
R. I. Jetter	M. Zhou, <i>Contributing Member</i>
C. C. Kim	E. B. Branch, <i>Honorary Member</i>
G. H. Koo	G. D. Cooper, <i>Honorary Member</i>
D. W. Lewis	D. F. Landers, <i>Honorary Member</i>
M. A. Lockwood	C. Pieper, <i>Honorary Member</i>
K. A. Manoly	

Executive Committee (BPV III)

R. B. Keating, <i>Chair</i>	K. A. Manoly
A. Maslowski, <i>Secretary</i>	D. E. Matthews
T. M. Adams	S. McKillop
P. R. Donavin	J. McLean
J. V. Gardiner	T.-L. Sham
J. Grimm	W. K. Sowder, Jr.
D. W. Lewis	K. A. Kavanagh, <i>Alternate</i>

Argentina International Working Group (BPV III)

M. F. Liendo, <i>Chair</i>	A. J. Dall'Osto
J. Fernández, <i>Vice Chair</i>	J. I. Duo
O. Martinez, <i>Staff Secretary</i>	M. M. Gamizo
O. A. Verastegui, <i>Secretary</i>	I. M. Guerreiro
E. H. Aldaz	I. A. Knorr
G. O. Anteri	D. E. Matthews
A. P. Antipasti	A. E. Pastor
D. O. Bordato	M. Rivero
G. Bourguigne	M. D. Vigliano
M. Brusa	P. Yamamoto
A. Claus	M. Zunino
R. G. Cocco	

China International Working Group (BPV III)

Y. Wang, <i>Chair</i>	C. Peiyin
H. Yu, <i>Secretary</i>	Z. Sun
L. Feng	G. Tang
J. Gu	L. Ting
L. Guo	F. Wu
C. Jiang	C. Yang
D. Kang	P. Yang
Y. Li	W. Yang
H. Lin	H. Yin
S. Liu	D. Yuangang
W. Liu	G. Zhang
J. Ma	D. Zhao
K. Mao	Z. Zhong
D. E. Matthews	Q. Zhou
J. Ming	H. Zhu
W. Pei	

Germany International Working Group (BPV III)

J. Wendt, <i>Chair</i>	C. Kuschke
D. Koelbl, <i>Vice Chair</i>	H.-W. Lange
R. Gersinska, <i>Secretary</i>	T. Ludwig
P. R. Donavin	X. Pitoiset
R. Döring	M. Reichert
C. G. Frantescu	G. Roos
A. Huber	J. Rudolph
R. E. Hueggenberg	L. Sybertz
C. Huttner	I. Tewes
E. Iacopetta	R. Tiete
M. H. Koeppen	F. Wille

India International Working Group (BPV III)

R. N. Sen, <i>Chair</i>	R. Kumar
S. B. Parkash, <i>Vice Chair</i>	S. Kumar
A. D. Bagdare, <i>Secretary</i>	M. Lakshminarasimhan
S. Aithal	T. Mukherjee
S. Benhur	D. Narain
N. M. Borwankar	A. D. Paranjpe
M. Brijlani	J. R. Patel
H. Dalal	E. L. Pleins
S. K. Goyal	T. J. P. Rao
A. Johori	V. Sehgal
A. P. Kishore	S. Singh
D. Kulkarni	B. K. Sreedhar

Korea International Working Group (BPV III)

G. H. Koo, <i>Chair</i>	Y.-S. Kim
O.-S. Kim, <i>Secretary</i>	D. Kwon
H. Ahn	B. Lee
S. Cho	D. Lee
G.-S. Choi	S. Lee
M.-J. Choi	S.-G. Lee
S. Choi	H. Lim
J. Y. Hong	I.-K. Nam
N.-S. Huh	C.-K. Oh
J.-K. Hwang	C.-Y. Oh
S. S. Hwang	E.-J. Oh
C. Jang	C. Park
I. I. Jeong	H. Park
S. H. Kang	Y. S. Pyun
J.-I. Kim	T. Shin
J.-S. Kim	S. Song
M.-W. Kim	W. J. Sperko
S.-S. Kim	J. S. Yang
Y.-B. Kim	O. Yoo

Seismic Design Steering Committee (BPV III)

T. M. Adams, <i>Chair</i>	G. H. Koo
F. G. Abatt, <i>Secretary</i>	A. Maekawa
G. A. Antaki	K. Matsunaga
C. Basavaraju	J. McLean
D. Chowdhury	R. M. Pace
R. Döring	D. Watkins

Task Group on Alternate Requirements (BPV III)

J. Wen, <i>Chair</i>	D. E. Matthews
R. R. Romano, <i>Secretary</i>	S. McKillop
P. J. Coco	B. P. Nolan
P. R. Donavin	J. B. Ossmann
J. V. Gardiner	E. C. Renaud
J. Grimm	M. A. Richter
R. S. Hill III	I. H. Tseng
M. Kris	Y. Wang
M. A. Lockwood	

United Kingdom International Working Group (BPV III)

C. D. Bell, <i>Chair</i>	G. Innes
P. M. James, <i>Vice Chair</i>	S. A. Jones
C. B. Carpenter, <i>Secretary</i>	B. Pellereau
T. M. Adams	C. R. Schneider
T. Bann	J. W. Stairmand
M. J. Chevalier	J. Sulley
A. J. Cole-Baker	J. Talamantes-Silva
M. Consonni	A. J. Holt, <i>Contributing Member</i>
M. J. Crathorne	

Special Working Group on New Plant Construction Issues (BPV III)

J. B. Ossmann, <i>Chair</i>	R. E. McLaughlin
A. Maslowski, <i>Staff Secretary</i>	E. L. Pleins
M. C. Buckley, <i>Secretary</i>	D. W. Sandusky
M. Arcaro	M. C. Scott
A. Cardillo	R. R. Stevenson
P. J. Coco	H. Xu
K. Harris	J. Yan
J. Honcharik	J. C. Minichiello, <i>Contributing Member</i>
M. Kris	

Special Working Group on Editing and Review (BPV III)

D. E. Matthews, <i>Chair</i>	S. Hunter
R. P. Deubler	J. C. Minichiello
A. C. Eberhardt	J. F. Strunk
J. V. Gardiner	C. Wilson

Special Working Group on HDPE Stakeholders (BPV III)

S. Patterson, <i>Secretary</i>	D. P. Munson
S. Choi	T. M. Musto
C. M. Faidy	J. E. O'Sullivan
M. Golliet	V. Rohatgi
R. M. Jessee	F. J. Schaaf, Jr.
J. Johnston, Jr.	R. Stakenborghs
M. Kuntz	M. Troughton
M. Lashley	B. Lin, <i>Alternate</i>
K. A. Manoly	

Special Working Group on Honors and Awards (BPV III)

J. C. Minichiello, <i>Chair</i>	R. M. Jessee
A. Appleton	D. E. Matthews
R. W. Barnes	

Special Working Group on International Meetings and IWG Liaisons (BPV III)

D. E. Matthews, <i>Chair</i>	P. R. Donavin
A. Maslowski, <i>Staff Secretary</i>	E. L. Pleins
T. M. Adams	W. J. Sperko
R. W. Barnes	

Joint ACI-ASME Committee on Concrete Components for Nuclear Service (BPV III)

J. McLean, *Chair*
L. J. Colarusso, *Vice Chair*
J. Cassamassino, *Staff Secretary*
A. Dinizulu, *Staff Secretary*
C. J. Bang
A. C. Eberhardt
B. D. Hovis
T. C. Inman
C. Jones
T. Kang
N.-H. Lee
J. A. Munshi
T. Muraki
J. S. Saini

J. F. Strunk
G. Thomas
A. Varma
S. Wang
A. Istar, *Alternate*
A. Adediran, *Contributing Member*
S. Bae, *Contributing Member*
J.-B. Domage, *Contributing Member*
P. S. Ghosal, *Contributing Member*
B. B. Scott, *Contributing Member*
M. R. Senecal, *Contributing Member*
Z. Shang, *Contributing Member*
M. Sircar, *Contributing Member*
C. T. Smith, *Contributing Member*

Special Working Group on Modernization (BPV III-2)

S. Wang, *Chair*
J. McLean, *Vice Chair*
A. Adediran
S. Malushte
J. S. Saini

A. Varma
F. Lin, *Contributing Member*
J. A. Pires, *Contributing Member*
I. Zivanovic, *Contributing Member*

Task Group on Steel-Concrete Composite Containments (BPV III-2)

A. Varma, *Chair*
S. Malushte
J. McLean

J. A. Pires
J. S. Saini

Working Group on Design (BPV III-2)

N.-H. Lee, *Chair*
S. Wang, *Vice Chair*
M. Allam
S. Bae
L. J. Colarusso
A. C. Eberhardt
B. D. Hovis
T. C. Inman
C. Jones
J. A. Munshi
T. Muraki
J. S. Saini

G. Thomas
A. Istar, *Alternate*
P. S. Ghosal, *Contributing Member*
S.-Y. Kim, *Contributing Member*
J. Kwon, *Contributing Member*
S. E. Ohler-Schmitz, *Contributing Member*
B. B. Scott, *Contributing Member*
Z. Shang, *Contributing Member*
M. Shin, *Contributing Member*
M. Sircar, *Contributing Member*

Working Group on Materials, Fabrication, and Examination (BPV III-2)

C. Jones, *Chair*
A. Eberhardt, *Vice Chair*
C. J. Bang
B. Birch
J.-B. Domage
T. Kang
N.-H. Lee

Z. Shang
J. F. Strunk
A. A. Aboelmagd, *Contributing Member*
P. S. Ghosal, *Contributing Member*
B. B. Scott, *Contributing Member*
I. Zivanovic, *Contributing Member*

Subcommittee on Design (BPV III)

P. R. Donavin, *Chair*
S. McKillop, *Vice Chair*
R. P. Deubler
M. A. Gray
R. I. Jetter
R. B. Keating
J.-I. Kim
K. A. Manoly
D. E. Matthews
M. N. Mitchell

B. Pellereau
T.-L. Sham
W. F. Weitzel
C. Basavaraju, *Alternate*
G. L. Hollinger, *Contributing Member*
M. H. Jawad, *Contributing Member*
W. J. O'Donnell, Sr., *Contributing Member*
K. Wright, *Contributing Member*

Subgroup on Component Design (SC-D) (BPV III)

D. E. Matthews, *Chair*
P. Vock, *Vice Chair*
S. Pellet, *Secretary*
T. M. Adams
D. J. Ammerman
G. A. Antaki
J. J. Arthur
S. Asada
J. F. Ball
C. Basavaraju
D. Chowdhury
N. A. Costanzo
R. P. Deubler
M. Kassar
D. Keck
T. R. Liszkai
K. A. Manoly
J. C. Minichiello

T. Mitsushashi
D. Murphy
T. M. Musto
T. Nagata
G. Z. Tokarski
S. Willoughby-Braun
C. Wilson
A. A. Dermenjian, *Contributing Member*
P. Hirschberg, *Contributing Member*
R. B. Keating, *Contributing Member*
O.-S. Kim, *Contributing Member*
R. J. Masterson, *Contributing Member*
H. S. Mehta, *Contributing Member*
I. Saito, *Contributing Member*
J. P. Tucker, *Contributing Member*

Task Group to Improve Section III/XI Interface (SG-CD) (BPV III)

P. Vock, *Chair*
E. Henry, *Secretary*
G. A. Antaki
A. Cardillo
D. Chowdhury
J. Honcharik
J. Hurst
J. Lambin

C. A. Nove
T. Nuoffer
J. B. Ossmann
A. T. Roberts III
J. Sculli
A. Udyawar
S. Willoughby-Braun

Working Group on Core Support Structures (SG-CD) (BPV III)

D. Keck, *Chair*
R. Z. Ziegler, *Vice Chair*
R. Martin, *Secretary*
G. W. Delpont
L. C. Hartless
T. R. Liszkai
M. Nakajima

M. D. Snyder
R. Vollmer
T. M. Wiger
C. Wilson
Y. Wong
H. S. Mehta, *Contributing Member*

Working Group on Design of Division 3 Containment Systems (SG-CD) (BPV III)

D. J. Ammerman, *Chair*
S. Klein, *Secretary*
G. Bjorkman
V. Broz
D. W. Lewis
J. M. Piotter
A. Rigato
P. Sakalaukus, Jr.

D. Siromani
R. Sypulski
X. Zhai
X. Zhang
C. R. Sydnor, *Alternate*
J. C. Minichiello, *Contributing Member*

Working Group on HDPE Design of Components (SG-CD) (BPV III)

T. M. Musto, <i>Chair</i>	K. A. Manoly
J. B. Ossmann, <i>Secretary</i>	D. P. Munson
M. Brandes	F. J. Schaaf, Jr.
S. Choi	R. Stakenborghs
J. R. Hebeisen	M. T. Audrain, <i>Alternate</i>
P. Krishnaswamy	J. C. Minichiello, <i>Contributing Member</i>
M. Kuntz	

Working Group on Valves (SG-CD) (BPV III)

P. Vock, <i>Chair</i>	H. O'Brien
S. Jones, <i>Secretary</i>	J. O'Callaghan
M. C. Buckley	M. Rain
A. Cardillo	K. E. Reid II
G. A. Jolly	J. Sulley
J. Lambin	I. H. Tseng
T. Lippucci	J. P. Tucker
C. A. Mizer	Y. Wong, <i>Alternate</i>

Working Group on Piping (SG-CD) (BPV III)

G. A. Antaki, <i>Chair</i>	J. O'Callaghan
G. Z. Tokarski, <i>Secretary</i>	K. E. Reid II
C. Basavaraju	D. Vlaicu
J. Catalano	S. Weindorf
F. Claeys	T. M. Adams, <i>Contributing Member</i>
C. M. Faidy	R. B. Keating, <i>Contributing Member</i>
R. G. Gilada	T. B. Littleton, <i>Contributing Member</i>
N. M. Graham	Y. Liu, <i>Contributing Member</i>
M. A. Gray	J. F. McCabe, <i>Contributing Member</i>
R. J. Gurdal	J. C. Minichiello, <i>Contributing Member</i>
R. W. Haupt	
A. Hirano	A. N. Nguyen, <i>Contributing Member</i>
P. Hirschberg	M. S. Sills, <i>Contributing Member</i>
M. Kassab	N. C. Sutherland, <i>Contributing Member</i>
J. Kawahata	
D. Lieb	E. A. Wais, <i>Contributing Member</i>
I.-K. Nam	C.-I. Wu, <i>Contributing Member</i>

Working Group on Vessels (SG-CD) (BPV III)

D. Murphy, <i>Chair</i>	T. J. Schriefer
S. Willoughby-Braun, <i>Secretary</i>	M. C. Scott
J. J. Arthur	P. K. Shah
C. Basavaraju	D. Vlaicu
M. Brijlani	C. Wilson
L. Constantinescu	R. Z. Ziegler
J. I. Kim	R. J. Huang, <i>Alternate</i>
O.-S. Kim	B. Basu, <i>Contributing Member</i>
D. E. Matthews	R. B. Keating, <i>Contributing Member</i>
T. Mitsuhashi	W. F. Weitze, <i>Contributing Member</i>

Working Group on Pressure Relief (SG-CD) (BPV III)

K. R. May, <i>Chair</i>	K. Shores
R. Krithivasan, <i>Secretary</i>	I. H. Tseng
M. Brown	B. J. Yonsky
J. W. Dickson	Y. Wong, <i>Alternate</i>
S. Jones	J. Yu, <i>Alternate</i>
R. Lack	S. T. French, <i>Contributing Member</i>
D. Miller	D. B. Ross, <i>Contributing Member</i>
T. Patel	S. Ruesenberg, <i>Contributing Member</i>

Subgroup on Design Methods (SC-D) (BPV III)

S. McKillop, <i>Chair</i>	W. D. Reinhardt
P. R. Donavin, <i>Vice Chair</i>	P. Smith
J. Wen, <i>Secretary</i>	R. Vollmer
K. Avrithi	W. F. Weitze
L. Davies	T. M. Adams, <i>Contributing Member</i>
M. A. Gray	C. W. Bruny, <i>Contributing Member</i>
J. V. Gregg, Jr.	S. R. Gosselin, <i>Contributing Member</i>
K. Hsu	H. T. Harrison III, <i>Contributing Member</i>
R. Kalnas	W. J. O'Donnell, Sr., <i>Contributing Member</i>
D. Keck	
J. I. Kim	K. Wright, <i>Contributing Member</i>
B. Pellereau	

Working Group on Pumps (SG-CD) (BPV III)

D. Chowdhury, <i>Chair</i>	K. B. Wilson
J. V. Gregg, Jr., <i>Secretary</i>	Y. Wong
B. Busse	I. H. Tseng, <i>Alternate</i>
M. D. Eftychiou	X. Di, <i>Contributing Member</i>
R. A. Fleming	C. Gabhart, <i>Contributing Member</i>
K. J. Noel	R. Ladefian, <i>Contributing Member</i>
J. Sulley	

Working Group on Supports (SG-CD) (BPV III)

N. A. Costanzo, <i>Chair</i>	G. Thomas
U. S. Bandyopadhyay, <i>Secretary</i>	G. Z. Tokarski
K. Avrithi	L. Vandersip
N. M. Bisceglia	P. Wiseman
R. P. Deubler	R. J. Masterson, <i>Contributing Member</i>
N. M. Graham	
Y. Matsubara	J. R. Stinson, <i>Contributing Member</i>
S. Pellet	

Special Working Group on Computational Modeling for Explicit Dynamics (SG-DM) (BPV III)

G. Bjorkman, <i>Chair</i>	D. Siromani
D. J. Ammerman, <i>Vice Chair</i>	C.-F. Tso
V. Broz, <i>Secretary</i>	M. C. Yaksh
S. Kuehner	U. Zencker
D. Molitoris	X. Zhang
W. D. Reinhardt	Y. Wong, <i>Contributing Member</i>

Working Group on Design Methodology (SG-DM) (BPV III)

B. Pellereau, *Chair*
 R. Vollmer, *Secretary*
 K. Avrithi
 C. Basavaraju
 F. Berkepille
 C. M. Faidy
 Y. Gao
 M. Kassar
 J. I. Kim
 T. R. Liszkai
 D. Lytle
 K. Matsunaga
 S. McKillop
 S. Ranganath
 W. D. Reinhardt
 P. K. Shah
 S. Wang
 W. F. Weitze

J. Wen
 T. M. Wiger
 K. Hsu, *Alternate*
 G. Banyay, *Contributing Member*
 D. S. Bartran, *Contributing Member*
 R. D. Blevins, *Contributing Member*
 M. R. Breach, *Contributing Member*
 C. W. Bruny, *Contributing Member*
 D. L. Caldwell, *Contributing Member*
 H. T. Harrison III, *Contributing Member*
 C. F. Heberling II, *Contributing Member*
 P. Hirschberg, *Contributing Member*
 R. B. Keating, *Contributing Member*
 A. Walker, *Contributing Member*
 K. Wright, *Contributing Member*

Working Group on Environmental Fatigue Evaluation Methods (SG-DM) (BPV III)

M. A. Gray, *Chair*
 W. F. Weitze, *Secretary*
 S. Asada
 K. Avrithi
 R. C. Cipolla
 T. M. Damiani
 C. M. Faidy
 A. Hirano
 P. Hirschberg
 K. Hsu
 J.-S. Park

B. Pellereau
 D. Vlaicu
 K. Wang
 R. Z. Ziegler
 S. Cuvilliez, *Contributing Member*
 T. D. Gilman, *Contributing Member*
 S. R. Gosselin, *Contributing Member*
 Y. He, *Contributing Member*
 H. S. Mehta, *Contributing Member*
 K. Wright, *Contributing Member*

Working Group on Fatigue Strength (SG-DM) (BPV III)

P. R. Donavin, *Chair*
 M. S. Shelton, *Secretary*
 R. S. Bass
 T. M. Damiani
 D. W. DeJohn
 C. M. Faidy
 P. Gill
 S. R. Gosselin
 R. J. Gurdal
 C. F. Heberling II
 C. E. Hinnant
 P. Hirschberg
 K. Hsu

J. I. Kim
 S. H. Kleinsmith
 B. Pellereau
 S. Ranganath
 Y. Wang
 W. F. Weitze
 Y. Zou
 S. Majumdar, *Contributing Member*
 H. S. Mehta, *Contributing Member*
 W. J. O'Donnell, Sr., *Contributing Member*
 K. Wright, *Contributing Member*

Working Group on Probabilistic Methods in Design (SG-DM) (BPV III)

M. Golliet, *Chair*
 R. Kalnas, *Vice Chair*
 K. Avrithi
 G. Brouette
 J. Hakii
 D. O. Henry

A. Hirano
 K. A. Manoly
 P. J. O'Regan
 B. Pellereau
 M. Yagodich
 R. S. Hill III, *Contributing Member*

Subgroup on Containment Systems for Spent Nuclear Fuel and High-Level Radioactive Material (BPV III)

D. W. Lewis, *Chair*
 D. J. Ammerman, *Vice Chair*
 S. Klein, *Secretary*
 G. Bjorkman
 V. Broz
 A. Rigato
 P. Sakalaukus, Jr.
 D. Siromani
 D. B. Spencer

R. Sypulski
 J. Wellwood
 X. J. Zhai
 X. Zhang
 D. Dunn, *Alternate*
 W. H. Borter, *Contributing Member*
 E. L. Pleins, *Contributing Member*
 N. M. Simpson, *Contributing Member*

Subgroup on Fusion Energy Devices (BPV III)

W. K. Sowder, Jr., *Chair*
 A. Maslowski, *Staff Secretary*
 M. Ellis, *Secretary*
 M. Bashir
 J. P. Blanchard
 T. P. Davis
 B. R. Doshi
 L. El-Guebaly
 G. Holtmeier
 D. Johnson
 I. Kimihiro

C. J. Lammi
 S. Lawler
 P. Mokaria
 D. J. Roszman
 F. J. Schaaf, Jr.
 P. Smith
 Y. Song
 C. Vangaasbeek
 I. J. Zatz
 R. W. Barnes, *Contributing Member*

Special Working Group on Fusion Stakeholders (BPV III-4)

T. P. Davis, *Chair*
 R. W. Barnes
 V. Chugh
 S. S. Desai
 F. Deschamps
 M. Hua
 S. Lawler

S. C. Middleburgh
 R. J. Pearson
 W. K. Sowder, Jr.
 D. A. Sutherland
 N. Young
 J. Zimmermann

Working Group on General Requirements (BPV III-4)

D. J. Roszman, *Chair*
 M. Ellis

P. Mokaria
 W. K. Sowder, Jr.

Working Group on In-Vessel Components (BPV III-4)

M. Bashir, *Chair*
 Y. Carin
 T. P. Davis

M. Kalsey
 S. T. Madabusi

Working Group on Magnets (BPV III-4)

W. K. Sowder, Jr., *Chair*

D. S. Bartran

Working Group on Materials (BPV III-4)

M. Porton, *Chair*
 T. P. Davis

P. Mummery

Working Group on Vacuum Vessels (BPV III-4)

I. Kimihiro, *Chair*
 L. C. Cadwallader
 B. R. Doshi

D. Johnson
 Q. Shijun
 Y. Song

Subgroup on General Requirements (BPV III)

J. V. Gardiner, <i>Chair</i>	E. C. Renaud
N. DeSantis, <i>Secretary</i>	T. N. Rezk
V. Apostolescu	J. Rogers
A. Appleton	R. Spuhl
S. Bell	D. M. Vickery
J. R. Berry	J. DeKleine, <i>Contributing Member</i>
G. Brouette	H. Michael, <i>Contributing Member</i>
G. C. Deleanu	D. J. Roszman, <i>Contributing Member</i>
J. W. Highlands	C. T. Smith, <i>Contributing Member</i>
E. V. Imbro	W. K. Sowder, Jr., <i>Contributing Member</i>
K. A. Kavanagh	G. E. Szabatura, <i>Contributing Member</i>
Y.-S. Kim	
B. McGlone	

Subgroup on High Temperature Reactors (BPV III)

T.-L. Sham, <i>Chair</i>	A. Mann
Y. Wang, <i>Secretary</i>	M. C. Messner
M. Ando	X. Wei
N. Broom	W. Windes
F. W. Brust	R. Wright
P. Carter	G. L. Zeng
M. E. Cohen	D. S. Griffin, <i>Contributing Member</i>
W. J. Geringer	X. Li, <i>Contributing Member</i>
B. F. Hantz	W. O'Donnell, Sr., <i>Contributing Member</i>
M. H. Jawad	L. Shi, <i>Contributing Member</i>
W. T. Jessup	R. W. Swindeman, <i>Contributing Member</i>
R. I. Jetter	
K. Kimura	
G. H. Koo	

Special Working Group on General Requirements Consolidation (SG-GR) (BPV III)

J. V. Gardiner, <i>Chair</i>	E. C. Renaud
J. Grimm, <i>Vice Chair</i>	J. L. Williams
G. C. Deleanu	C. T. Smith, <i>Contributing Member</i>
A. C. Eberhardt	

Special Working Group on High Temperature Reactor Stakeholders (SG-HTR) (BPV III)

M. E. Cohen, <i>Chair</i>	G. H. Koo
M. C. Albert	N. J. McTiernan
M. Arcaro	T. Nguyen
R. W. Barnes	K. J. Noel
N. Broom	T.-L. Sham
R. Christensen	B. Song
V. Chugh	X. Wei
W. Corwin	G. L. Zeng
G. C. Deleanu	T. Asayama, <i>Contributing Member</i>
R. A. Fleming	X. Li, <i>Contributing Member</i>
K. Harris	L. Shi, <i>Contributing Member</i>
R. I. Jetter	G. Wu, <i>Contributing Member</i>
Y. W. Kim	

Working Group on General Requirements (SG-GR) (BPV III)

B. McGlone, <i>Chair</i>	Y. K. Law
J. Grimm, <i>Secretary</i>	D. T. Meisch
V. Apostolescu	E. C. Renaud
A. Appleton	T. N. Rezk
S. Bell	J. Rogers
J. R. Berry	B. S. Sandhu
G. Brouette	R. Spuhl
P. J. Coco	J. F. Strunk
N. DeSantis	D. M. Vickery
Y. Diaz-Castillo	J. L. Williams
O. Elkadim	J. DeKleine, <i>Contributing Member</i>
J. Harris	S. F. Harrison, Jr., <i>Contributing Member</i>
J. W. Highlands	D. J. Roszman, <i>Contributing Member</i>
E. V. Imbro	G. E. Szabatura, <i>Contributing Member</i>
K. A. Kavanagh	
Y.-S. Kim	

Task Group on Division 5 AM Components (SG-HTR) (BPV III)

R. Wright, <i>Chair</i>	M. McMurtrey
R. Bass, <i>Secretary</i>	M. C. Messner
M. C. Albert	T. Patterson
R. W. Barnes	E. C. Renaud
F. W. Brust	D. Rudland
Z. Feng	T.-L. Sham
S. Lawler	I. J. Van Rooyen
X. Lou	X. Wei

Working Group on General Requirements for Graphite and Ceramic Composite Core Components and Assemblies (SG-GR) (BPV III)

W. J. Geringer, <i>Chair</i>	M. N. Mitchell
A. Appleton	J. Potgieter
J. R. Berry	E. C. Renaud
C. Cruz	R. Spuhl
Y. Diaz-Castillo	W. Windes
J. Lang	B. Lin, <i>Alternate</i>

Working Group on Allowable Stress Criteria (SG-HTR) (BPV III)

R. Wright, <i>Chair</i>	W. Ren
M. McMurtrey, <i>Secretary</i>	T.-L. Sham
R. Bass	Y. Wang
K. Kimura	X. Wei
D. Maitra	M. Yoo, <i>Alternate</i>
R. J. McReynolds	R. W. Swindeman, <i>Contributing Member</i>
M. C. Messner	
J. C. Poehler	

Working Group on Analysis Methods (SG-HTR) (BPV III)

M. C. Messner, <i>Chair</i>	T.-L. Sham
H. Mahajan, <i>Secretary</i>	X. Wei
R. W. Barnes	S. X. Xu
J. A. Blanco	J. Young
P. Carter	M. R. Breach, <i>Contributing Member</i>
W. T. Jessup	T. Hassan, <i>Contributing Member</i>
R. I. Jetter	S. Krishnamurthy, <i>Contributing Member</i>
G. H. Koo	M. J. Swindeman, <i>Contributing Member</i>
H. Qian	
T. Riordan	

Working Group on Creep-Fatigue and Negligible Creep (SG-HTR) (BPV III)

Y. Wang, <i>Chair</i>	M. C. Messner
M. Ando	T. Nguyen
P. Carter	J. C. Poehler
M. E. Cohen	H. Qian
J. I. Duo	R. Rajasekaran
R. I. Jetter	T.-L. Sham
G. H. Koo	X. Wei
H. Mahajan	J. Young
M. McMurtrey	M. Yoo, <i>Alternate</i>

Working Group on High Temperature Flaw Evaluation (SG-HTR) (BPV III)

C. J. Sallaberry, <i>Chair</i>	H. Qian
F. W. Brust	D. A. Scarth
P. Carter	D. J. Shim
S. Kalyanam	A. Udyawar
B.-L. Lyow	X. Wei
M. C. Messner	S. X. Xu
J. C. Poehler	M. Yoo, <i>Alternate</i>

Working Group on Nonmetallic Design and Materials (SG-HTR) (BPV III)

W. Windes, <i>Chair</i>	M. N. Mitchell
W. J. Geringer, <i>Vice Chair</i>	J. Parks
J. Potgieter, <i>Secretary</i>	T.-L. Sham
G. Beirnaert	A. Tzelepi
C. Chen	G. L. Zeng
A. N. Chereskin	M. Yoo, <i>Alternate</i>
V. Chugh	A. Appleton, <i>Contributing Member</i>
C. Contescu	R. W. Barnes, <i>Contributing Member</i>
N. Gallego	A. A. Campbell, <i>Contributing Member</i>
S. T. Gonczy	S.-H. Chi, <i>Contributing Member</i>
K. Harris	Y. Katoh, <i>Contributing Member</i>
M. G. Jenkins	A. Mack, <i>Contributing Member</i>
J. Lang	J. B. Ossmann, <i>Contributing Member</i>
M. P. Metcalfe	

Subgroup on Materials, Fabrication, and Examination (BPV III)

J. Grimm, <i>Chair</i>	M. Kris
S. Hunter, <i>Secretary</i>	D. W. Mann
W. H. Bortner	T. Melfi
M. Brijlani	I.-K. Nam
G. R. Cannell	J. B. Ossmann
A. Cardillo	J. E. O'Sullivan
S. Cho	M. C. Scott
P. J. Coco	W. J. Sperko
R. H. Davis	J. R. Stinson
D. B. Denis	J. F. Strunk
B. D. Frew	W. Windes
D. W. Gandy	R. Wright
S. E. Gingrich	S. Yee
M. Golliet	H. Michael, <i>Delegate</i>
L. S. Harbison	A. L. Hiser, Jr., <i>Alternate</i>
R. M. Jessee	R. W. Barnes, <i>Contributing Member</i>
C. C. Kim	

Task Group on Advanced Manufacturing (BPV III)

D. W. Mann, <i>Chair</i>	T. Melfi
D. W. Gandy, <i>Secretary</i>	E. C. Renaud
R. Bass	W. J. Sperko
D. Chowdhury	J. F. Strunk
P. J. Coco	J. Sulley
B. D. Frew	S. Tate
J. Grimm	S. Wolbert
A. L. Hiser, Jr.	H. Xu
J. Lambin	D. W. Pratt, <i>Alternate</i>
T. Lippucci	S. Malik, <i>Contributing Member</i>
K. Matsunaga	

Joint Working Group on HDPE (SG-MFE) (BPV III)

M. Brandes, <i>Chair</i>	K. Manoly
T. M. Musto, <i>Chair</i>	D. P. Munson
J. B. Ossmann, <i>Secretary</i>	J. O'Sullivan
G. Brouette	V. Rohatgi
M. C. Buckley	F. Schaaf, Jr.
S. Choi	S. Schuessler
M. Golliet	R. Stakenborghs
J. Hebeisen	M. Troughton
J. Johnston, Jr.	P. Vibien
P. Krishnaswamy	J. Wright
M. Kuntz	T. Adams, <i>Contributing Member</i>
B. Lin	

COMMITTEE ON HEATING BOILERS (BPV IV)

M. Wadkinson, <i>Chair</i>	C. Dinic
J. L. Kleiss, <i>Vice Chair</i>	J. M. Downs
C. R. Ramcharran, <i>Staff Secretary</i>	J. A. Hall
B. Ahee	M. Mengon
L. Badziagowski	D. Nelson
T. L. Bedeaux	H. Michael, <i>Delegate</i>
B. Calderon	D. Picart, <i>Delegate</i>
J. P. Chicoine	P. A. Molvie, <i>Contributing Member</i>

Executive Committee (BPV IV)

M. Wadkinson, <i>Chair</i>	J. P. Chicoine
C. R. Ramcharran, <i>Staff Secretary</i>	J. A. Hall
L. Badziagowski	J. L. Kleiss
T. L. Bedeaux	

Subgroup on Cast Boilers (BPV IV)

J. P. Chicoine, *Chair* J. A. Hall
J. M. Downs, *Vice Chair* J. L. Kleiss
C. R. Ramcharran, *Staff Secretary* M. Mengon
T. L. Bedeaux

Subgroup on Materials (BPV IV)

J. A. Hall, *Chair* T. L. Bedeaux
J. M. Downs, *Vice Chair* Y. Teng
C. R. Ramcharran, *Staff Secretary* M. Wadkinson
L. Badziagowski

Subgroup on Water Heaters (BPV IV)

J. L. Kleiss, *Chair* B. J. Iske
L. Badziagowski, *Vice Chair* M. Mengon
C. R. Ramcharran, *Staff Secretary* Y. Teng
B. Ahee T. E. Trant
J. P. Chicoine P. A. Molvie, *Contributing Member*
C. Dinic

Subgroup on Welded Boilers (BPV IV)

T. L. Bedeaux, *Chair* J. L. Kleiss
C. R. Ramcharran, *Staff Secretary* M. Mengon
B. Ahee M. Wadkinson
L. Badziagowski M. J. Melita, *Alternate*
B. Calderon D. Nelson, *Alternate*
J. P. Chicoine P. A. Molvie, *Contributing Member*
C. Dinic

Europe International Working Group (BPV IV)

L. Badziagowski, *Chair* E. Van Bruggen
D. Picart, *Vice Chair* G. Vicchi
R. Lozny A. Alessandrini, *Alternate*

COMMITTEE ON NONDESTRUCTIVE EXAMINATION (BPV V)

N. A. Finney, *Chair* B. D. Laite
C. May, *Vice Chair* P. B. Shaw
C. R. Ramcharran, *Staff Secretary* C. Vorwald
D. Bajula S. J. Akryn, *Contributing Member*
P. L. Brown J. E. Batey, *Contributing Member*
M. A. Burns A. S. Birks, *Contributing Member*
N. Carter N. Y. Faransso, *Contributing Member*
T. Clausing J. F. Halley, *Contributing Member*
C. Emslander R. W. Kruzic, *Contributing Member*
A. F. Garbolevsky L. E. Mullins, *Contributing Member*
P. T. Hayes F. J. Sattler, *Contributing Member*
G. W. Hembree H. C. Graber, *Honorary Member*
F. B. Kovacs T. G. McCarty, *Honorary Member*
K. Krueger

Executive Committee (BPV V)

C. May, *Chair* G. W. Hembree
N. A. Finney, *Vice Chair* F. B. Kovacs
C. R. Ramcharran, *Staff Secretary* K. Krueger
N. Carter E. Peloquin
V. F. Godinez-Azcuaga C. Vorwald
P. T. Hayes

Subgroup on General Requirements/Personnel Qualifications and Inquiries (BPV V)

C. Vorwald, *Chair* F. B. Kovacs
D. Bajula K. Krueger
N. Carter C. May
P. Chavdarov S. J. Akryn, *Contributing Member*
T. Clausing N. Y. Faransso, *Contributing Member*
C. Emslander J. F. Halley, *Contributing Member*
N. A. Finney D. I. Morris, *Contributing Member*
G. W. Hembree J. P. Swezy, Jr., *Contributing Member*

Project Team on Assisted Analysis (BPV V)

K. Hayes, *Chair* C. Hansen
J. Aldrin G. W. Hembree
J. Chen R. S. F. Orozco
N. A. Finney E. Peloquin
V. F. Godinez-Azcuaga T. Thulien

Subgroup on Volumetric Methods (BPV V)

C. May, *Chair* K. Krueger
P. T. Hayes, *Vice Chair* E. Peloquin
D. Adkins C. Vorwald
P. L. Brown S. J. Akryn, *Contributing Member*
N. A. Finney N. Y. Faransso, *Contributing Member*
A. F. Garbolevsky J. F. Halley, *Contributing Member*
R. W. Hardy R. W. Kruzic, *Contributing Member*
G. W. Hembree L. E. Mullins, *Contributing Member*
F. B. Kovacs F. J. Sattler, *Contributing Member*

Working Group on Radiography (SG-VM) (BPV V)

C. Vorwald, *Chair* T. R. Lerohl
D. M. Woodward, *Vice Chair* C. May
J. Anderson R. J. Mills
P. L. Brown J. F. Molinaro
C. Emslander T. Vidimos
A. F. Garbolevsky B. White
R. W. Hardy S. J. Akryn, *Contributing Member*
G. W. Hembree T. L. Clifford, *Contributing Member*
F. B. Kovacs N. Y. Faransso, *Contributing Member*
B. D. Laite R. W. Kruzic, *Contributing Member*

Working Group on Ultrasonics (SG-VM) (BPV V)

K. Krueger, *Chair* D. Tompkins
D. Bajula, *Vice Chair* D. Van Allen
D. Adkins J. Vinyard
C. Brown C. Vorwald
C. Emslander C. Wassink
N. A. Finney N. Y. Faransso, *Contributing Member*
P. T. Hayes J. F. Halley, *Contributing Member*
G. W. Hembree R. W. Kruzic, *Contributing Member*
B. D. Laite P. Mudge, *Contributing Member*
T. R. Lerohl L. E. Mullins, *Contributing Member*
C. May M. J. Quarry, *Contributing Member*
E. Peloquin F. J. Sattler, *Contributing Member*
J. Schoneweis J. Vanvelsor, *Contributing Member*

Working Group on Acoustic Emissions (SG-VM) (BPV V)

V. F. Godinez-Azcuaga, *Chair*
 J. Catty, *Vice Chair*
 S. R. Doctor

N. F. Douglas, Jr.
 R. K. Miller
 N. Y. Faransso, *Contributing Member*

Working Group on Full Matrix Capture (SG-VM) (BPV V)

E. Peloquin, *Chair*
 C. Wassink, *Vice Chair*
 D. Bajula
 D. Bellistri
 J. Catty
 N. A. Finney
 J. L. Garner
 R. T. Grotenhuis
 P. T. Hayes

G. W. Hembree
 K. Krueger
 M. Lozev
 R. Nogueira
 D. Richard
 M. Sens
 D. Tompkins
 J. F. Halley, *Contributing Member*
 L. E. Mullins, *Contributing Member*

Subgroup on Inservice Examination Methods and Techniques (BPV V)

P. T. Hayes, *Chair*
 E. Peloquin, *Vice Chair*
 M. A. Burns
 M. Carlson
 N. A. Finney
 V. F. Godinez-Azcuaga

G. W. Hembree
 K. Krueger
 C. May
 D. D. Raimander
 C. Vorwald

Subgroup on Surface Examination Methods (BPV V)

N. Carter, *Chair*
 B. D. Laite, *Vice Chair*
 R. M. Beldyk
 P. L. Brown
 T. Clausing
 C. Emslander
 N. Farenbaugh
 N. A. Finney
 A. F. Garbolevsky
 K. Hayes
 G. W. Hembree
 C. May

P. B. Shaw
 R. Tedder
 C. Vorwald
 C. Wassink
 D. M. Woodward
 S. J. Akryn, *Contributing Member*
 N. Y. Faransso, *Contributing Member*
 J. F. Halley, *Contributing Member*
 R. W. Kruzic, *Contributing Member*
 L. E. Mullins, *Contributing Member*
 F. J. Sattler, *Contributing Member*

Germany International Working Group (BPV V)

P. Chavdarov, *Chair*
 C. Kringe, *Vice Chair*
 H.-P. Schmitz, *Secretary*
 K.-H. Gischler

D. Kaiser
 S. Mann
 V. Reusch

India International Working Group (BPV V)

P. Kumar, *Chair*
 A. V. Bhagwat
 J. Chahwala
 S. Jobanputra
 D. Joshi

G. R. Joshi
 A. Relekar
 V. J. Sonawane
 D. B. Tanpure

Italy International Working Group (BPV V)

D. D. Raimander, *Chair*
 O. Oldani, *Vice Chair*
 C. R. Ramcharan, *Staff Secretary*
 P. Campli, *Secretary*
 M. Agostini
 T. Aldo
 F. Bresciani
 N. Caputo
 M. Colombo
 P. L. Dinelli
 F. Ferrarese

E. Ferrari
 M. A. Grimoldi
 G. Luoni
 U. Pappionetti
 P. Pedersoli
 A. Veroni
 M. Zambon
 V. Calo, *Contributing Member*
 G. Gobbi, *Contributing Member*
 A. Gusmaroli, *Contributing Member*
 G. Pontiggia, *Contributing Member*

COMMITTEE ON PRESSURE VESSELS (BPV VIII)

S. C. Roberts, *Chair*
 M. D. Lower, *Vice Chair*
 S. J. Rossi, *Staff Secretary*
 G. Auriolles, Sr.
 S. R. Babka
 R. J. Basile
 P. Chavdarov
 D. B. DeMichael
 J. F. Grubb
 B. F. Hantz
 M. Kowalczyk
 D. L. Kurle
 R. Mahadeen
 S. A. Marks
 P. Matkovics
 R. W. Mikitka
 B. R. Morelock
 T. P. Pastor
 D. T. Peters
 M. J. Pischke
 M. D. Rana
 G. B. Rawls, Jr.
 F. L. Richter

C. D. Rodery
 J. C. Sowinski
 D. Srnic
 D. B. Stewart
 P. L. Sturgill
 K. Subramanian
 D. A. Swanson
 J. P. Swezy, Jr.
 S. Terada
 E. Uptis
 A. Viet
 K. Xu
 P. A. McGowan, *Delegate*
 H. Michael, *Delegate*
 K. Oyamada, *Delegate*
 M. E. Pappionetti, *Delegate*
 A. Chaudouet, *Contributing Member*
 J. P. Glaspie, *Contributing Member*
 K. T. Lau, *Contributing Member*
 U. R. Miller, *Contributing Member*
 K. Mokhtarian, *Contributing Member*
 G. G. Karcher, *Honorary Member*
 K. K. Tam, *Honorary Member*

Executive Committee (BPV VIII)

M. D. Lower, *Chair*
 S. J. Rossi, *Staff Secretary*
 G. Auriolles, Sr.
 C. W. Cary
 J. Hoskinson
 M. Kowalczyk

S. A. Marks
 P. Matkovics
 S. C. Roberts
 J. C. Sowinski
 K. Subramanian
 K. Xu

Subgroup on Design (BPV VIII)

J. C. Sowinski, *Chair*
 C. S. Hinson, *Vice Chair*
 G. Auriolles, Sr.
 S. R. Babka
 O. A. Barsky
 R. J. Basile
 D. Chandiramani
 M. D. Clark
 M. Faulkner
 B. F. Hantz
 C. E. Hinnant
 M. H. Jawad
 S. Krishnamurthy
 D. L. Kurle
 K. Kuscu
 M. D. Lower
 R. W. Mikitka
 B. Millet

M. D. Rana
 G. B. Rawls, Jr.
 S. C. Roberts
 C. D. Rodery
 T. G. Seipp
 D. Srnic
 D. A. Swanson
 S. Terada
 J. Vattappilly
 K. Xu
 K. Oyamada, *Delegate*
 M. E. Papponetti, *Delegate*
 P. K. Lam, *Contributing Member*
 K. Mokhtarian, *Contributing Member*
 T. P. Pastor, *Contributing Member*
 S. C. Shah, *Contributing Member*
 K. K. Tam, *Contributing Member*
 E. Uptis, *Contributing Member*

Subgroup on General Requirements (BPV VIII)

J. Hoskinson, *Chair*
 M. Faulkner, *Vice Chair*
 N. Barkley
 R. J. Basile
 T. P. Beirne
 D. B. DeMichael
 M. D. Lower
 T. P. Pastor
 I. Powell
 G. B. Rawls, Jr.

F. L. Richter
 S. C. Roberts
 J. Rust
 J. C. Sowinski
 P. Speranza
 D. Srnic
 D. B. Stewart
 D. A. Swanson
 J. P. Glaspie, *Contributing Member*
 Y. Yang, *Contributing Member*

Task Group on Fired Heater Pressure Vessels (BPV VIII)

J. Hoskinson, *Chair*
 W. Kim
 S. Kirk
 D. Nelson
 T. P. Pastor

R. Robles
 J. Rust
 P. Shanks
 E. Smith
 D. Srnic

Working Group on Design-by-Analysis (BPV VIII)

B. F. Hantz, *Chair*
 T. W. Norton, *Secretary*
 D. A. Arnett
 J. Bedoya
 S. Guzey
 C. F. Heberling II
 C. E. Hinnant
 M. H. Jawad
 S. Kataoka
 S. Kilambi
 K. D. Kirkpatrick

S. Krishnamurthy
 A. Mann
 C. Nadarajah
 P. Prueter
 T. G. Seipp
 M. A. Shah
 S. Terada
 R. G. Brown, *Contributing Member*
 D. Dewees, *Contributing Member*
 K. Saboda, *Contributing Member*

Task Group on Subsea Applications (BPV VIII)

M. Sarzynski, *Chair*
 A. J. Grohmann, *Vice Chair*
 L. P. Antalffy
 R. C. Biel
 J. Ellens
 J. Hademenos
 J. Kaculi
 K. Karpanan
 F. Kirkemo

C. Lan
 P. Lutkiewicz
 N. McKie
 S. K. Parimi
 R. H. Patil
 M. P. Vaclavik
 R. Cordes, *Contributing Member*
 D. T. Peters, *Contributing Member*
 J. R. Sims, *Contributing Member*

Working Group on Elevated Temperature Design (BPV I and VIII)

A. Mann, *Chair*
 C. Nadarajah, *Secretary*
 D. Anderson
 D. Dewees
 B. F. Hantz
 M. H. Jawad
 R. I. Jetter
 S. Krishnamurthy

T. Le
 M. C. Messner
 M. N. Mitchell
 P. Prueter
 M. J. Swindeman
 J. P. Glaspie, *Contributing Member*
 N. McMurray, *Contributing Member*
 B. J. Mollitor, *Contributing Member*

Subgroup on Heat Transfer Equipment (BPV VIII)

P. Matkovic, *Chair*
 M. D. Clark, *Vice Chair*
 L. Bower, *Secretary*
 G. Auriolles, Sr.
 S. R. Babka
 J. H. Barbee
 O. A. Barsky
 T. Bunyarattaphantu
 A. Chaudouet
 D. L. Kurle

R. Mahadeen
 S. Mayeux
 S. Neilsen
 E. Smith
 A. M. Voytko
 R. P. Wiberg
 J. Pasek, *Contributing Member*
 D. Srnic, *Contributing Member*
 Z. Tong, *Contributing Member*

Subgroup on Fabrication and Examination (BPV VIII)

S. A. Marks, *Chair*
 D. I. Morris, *Vice Chair*
 T. Halligan, *Secretary*
 N. Carter
 J. Lu
 B. R. Morelock
 O. Mulet
 M. J. Pischke
 M. J. Rice
 J. Roberts
 C. D. Rodery

B. F. Shelley
 D. Smith
 P. L. Sturgill
 J. P. Swezy, Jr.
 E. Uptis
 C. Violand
 K. Oyamada, *Delegate*
 W. J. Bees, *Contributing Member*
 L. F. Campbell, *Contributing Member*
 R. Uebel, *Contributing Member*

Working Group on Plate Heat Exchangers (BPV VIII)

D. I. Morris, *Chair*
 S. R. Babka
 J. F. Grubb
 V. Gudge
 R. Mahadeen
 S. A. Marks

P. Matkovic
 M. J. Pischke
 P. Shanks
 E. Smith
 D. Srnic
 S. Sullivan

Subgroup on High Pressure Vessels (BPV VIII)

K. Subramanian, *Chair*
M. Sarzynski, *Vice Chair*
A. Dinizulu, *Staff Secretary*
L. P. Antalffy
J. Barlow
R. C. Biel
P. N. Chaku
L. Fridlund
D. Fuenmayor
J. Gibson
R. T. Hallman
K. Karpanan
J. Keltjens
A. K. Khare
G. T. Nelson
D. T. Peters
E. D. Roll
J. R. Sims
E. Smith
F. W. Tatar

S. Terada
Y. Xu
A. M. Clayton, *Contributing Member*
R. Cordes, *Contributing Member*
R. D. Dixon, *Contributing Member*
Q. Dong, *Contributing Member*
T. A. Duffey, *Contributing Member*
R. M. Hoshman, *Contributing Member*
F. Kirkemo, *Contributing Member*
R. A. Leishear, *Contributing Member*
G. M. Mital, *Contributing Member*
M. Parr, *Contributing Member*
M. D. Rana, *Contributing Member*
C. Romero, *Contributing Member*
C. Tipple, *Contributing Member*
K.-J. Young, *Contributing Member*
D. J. Burns, *Honorary Member*
G. J. Mraz, *Honorary Member*

Subgroup on Materials (BPV VIII)

M. Kowalczyk, *Chair*
P. Chavdarov, *Vice Chair*
S. Kilambi, *Secretary*
J. Cameron
J. F. Grubb
D. Maitra
D. W. Rahoi
J. Robertson
R. C. Sutherlin

E. Uptis
K. Xu
S. Yem
A. Di Rienzo, *Contributing Member*
J. D. Fritz, *Contributing Member*
M. Katcher, *Contributing Member*
W. M. Lundy, *Contributing Member*
J. Penso, *Contributing Member*

Subgroup on Toughness (BPV VIII)

K. Xu, *Chair*
T. Halligan, *Vice Chair*
T. Finn
C. S. Hinson
S. Kilambi
D. L. Kurle
T. Newman
J. Qu
M. D. Rana
F. L. Richter
K. Subramanian

D. A. Swanson
J. P. Swezy, Jr.
S. Terada
E. Uptis
J. Vattappilly
K. Oyamada, *Delegate*
L. Dong, *Contributing Member*
S. Krishnamurthy, *Contributing Member*
K. Mokhtarian, *Contributing Member*

Subgroup on Graphite Pressure Equipment (BPV VIII)

C. W. Cary, *Chair*
A. Viet, *Vice Chair*
G. C. Becherer
F. L. Brown
R. J. Bulgin

J. D. Clements
H. Lee, Jr.
S. Mehrez
T. Rudy
A. A. Stupica

Argentina International Working Group (BPV VIII)

A. Dominguez, *Chair*
R. Robles, *Vice Chair*
G. Glissenti, *Secretary*
M. M. Acosta
R. A. Barey
C. Alderetes
F. A. Andres
A. Antipasti
D. A. Bardelli
L. F. Bocanera
O. S. Bretones
A. Burgueno
G. Casanas
D. H. Da Rold
D. A. Del Teglia
J. I. Duo

M. Favareto
M. D. Kuhn
F. P. Larrosa
L. M. Leccese
C. Meinl
M. A. Mendez
J. J. Monaco
C. Parente
M. A. A. Pipponzi
L. C. Rigoli
A. Rivas
D. Rizzo
J. C. Rubeo
S. Schamun
G. Telleria
M. M. C. Tocco

China International Working Group (BPV VIII)

X. Chen, *Chair*
B. Shou, *Vice Chair*
Z. Fan, *Secretary*
Y. Chen
J. Cui
R. Duan
J.-G. Gong
B. Han
J. Hu
Q. Hu
H. Hui
K. Li
D. Luo
Y. Luo

C. Miao
L. Sun
C. Wu
J. Xiaobin
F. Xu
G. Xu
F. Yang
Y. Yang
Y. Yuan
Yanfeng Zhang
Yijun Zhang
S. Zhao
J. Zheng
G. Zhu

Germany International Working Group (BPV VIII)

R. Kauer, *Chair*
M. Sykora, *Vice Chair*
A. Aloui
P. Chavdarov
A. Emrich
J. Fleischfresser
C. Jaekel
D. Koelbl

S. Krebs
T. Ludwig
R. A. Meyers
H. Michael
S. Reich
A. Spangenberg
C. Stobbe
G. Naumann, *Contributing Member*

India International Working Group (BPV VIII)

D. Chandiramani, *Chair*
D. Kulkarni, *Vice Chair*
A. D. Dalal, *Secretary*
P. Arulkumar
B. Basu
P. Gandhi
U. Ganesan
S. K. Goyal
V. Jayabalan
V. K. Joshi

A. Kakumanu
V. V. P. Kumar
T. Mukherjee
P. C. Pathak
D. Prabhu
A. Sadasivam
M. P. Shah
R. Tiru
V. T. Valavan
M. Sharma, *Contributing Member*

Italy International Working Group (BPV VIII)

A. Teli, *Chair*
M. Millefanti, *Vice Chair*
P. Campli, *Secretary*
B. G. Alborali
P. Aliprandi
A. Avogadri
A. Camanni
N. Caputo
M. Colombo
P. Conti
D. Cortassa
P. L. Dinelli
F. Finco

M. Guglielmetti
A. F. Magri
P. Mantovani
L. Moracchioli
P. Pacor
S. Sarti
V. Calo, *Contributing Member*
G. Gobbi, *Contributing Member*
A. Gusmaroli, *Contributing Member*
G. Pontiggia, *Contributing Member*
D. D. Raimander, *Contributing Member*

Special Working Group on Bolted Flanged Joints (BPV VIII)

W. Brown, *Chair*
M. Osterfoss, *Vice Chair*
G. Aurioles, Sr.
D. Bankston, Jr.
H. Bouzid
A. Chaudouet
H. Chen
D. Francis
H. Lejeune
A. Mann

W. McDaniel
R. W. Mikitka
D. Nash
M. Ruffin
R. Wacker
E. Jamalyaria, *Contributing Member*
J. R. Payne, *Contributing Member*
G. Van Zyl, *Contributing Member*
J. Veiga, *Contributing Member*

Subgroup on Interpretations (BPV VIII)

G. Aurioles, Sr., *Chair*
J. Oh, *Staff Secretary*
S. R. Babka
J. Cameron
C. W. Cary
B. F. Hantz
M. Kowalczyk
D. L. Kurle
M. D. Lower
S. A. Marks
P. Matkovic
D. I. Morris
D. T. Peters
F. L. Richter
S. C. Roberts
C. D. Rodery
T. G. Seipp

J. C. Sowinski
D. B. Stewart
K. Subramanian
D. A. Swanson
J. P. Swezy, Jr.
J. Vattappilly
A. Viet
K. Xu
R. J. Basile, *Contributing Member*
D. B. DeMichael, *Contributing Member*
R. D. Dixon, *Contributing Member*
S. Kilambi, *Contributing Member*
R. Mahadeen, *Contributing Member*
T. P. Pastor, *Contributing Member*
P. L. Sturgill, *Contributing Member*

COMMITTEE ON WELDING, BRAZING, AND FUSING (BPV IX)

M. J. Pischke, *Chair*
P. L. Sturgill, *Vice Chair*
R. Rahaman, *Staff Secretary*
M. Bernasek
M. A. Boring
D. A. Bowers
N. Carter
J. G. Feldstein
P. Gilston
S. E. Gingrich
K. L. Hayes
R. M. Jessee
J. S. Lee
W. M. Lundy
D. W. Mann
S. A. Marks
T. Melfi
W. F. Newell, Jr.
E. G. Reichelt
M. J. Rice

M. B. Sims
W. J. Sperko
J. P. Swezy, Jr.
A. D. Wilson
E. W. Woelfel
D. Pojatar, *Delegate*
A. Roza, *Delegate*
M. Consonni, *Contributing Member*
P. D. Flenner, *Contributing Member*
S. A. Jones, *Contributing Member*
D. K. Peetz, *Contributing Member*
S. Raghunathan, *Contributing Member*
M. J. Stanko, *Contributing Member*
P. L. Van Fosson, *Contributing Member*
R. K. Brown, Jr., *Honorary Member*
M. L. Carpenter, *Honorary Member*
B. R. Newmark, *Honorary Member*
S. D. Reynolds, Jr., *Honorary Member*

Subgroup on Brazing (BPV IX)

S. A. Marks, *Chair*
E. W. Beckman
A. F. Garbolevsky
N. Mohr

M. J. Pischke
P. L. Sturgill
J. P. Swezy, Jr.

Subgroup on General Requirements (BPV IX)

N. Carter, *Chair*
P. Gilston, *Vice Chair*
J. P. Bell
D. A. Bowers
M. Heinrichs
A. Howard
R. M. Jessee
S. A. Marks
H. B. Porter

P. L. Sturgill
J. P. Swezy, Jr.
E. W. Woelfel
E. W. Beckman, *Contributing Member*
A. Davis, *Contributing Member*
D. K. Peetz, *Contributing Member*
B. R. Newmark, *Honorary Member*

Subgroup on Materials (BPV IX)

M. Bernasek, *Chair*
T. Anderson
L. Constantinescu
E. Cutlip
M. Denault
S. E. Gingrich
L. S. Harbison
M. James
R. M. Jessee
T. Melfi
S. D. Nelson

M. J. Pischke
A. Roza
C. E. Sainz
P. L. Sturgill
C. Zanfir
V. G. V. Giunto, *Delegate*
D. J. Kotecki, *Contributing Member*
B. Krueger, *Contributing Member*
W. J. Sperko, *Contributing Member*
M. J. Stanko, *Contributing Member*

Subgroup on Plastic Fusing (BPV IX)

K. L. Hayes, *Chair*
R. M. Jessee
J. Johnston, Jr.
J. E. O'Sullivan
E. G. Reichelt
M. J. Rice

S. Schuessler
M. Troughton
C. Violand
E. W. Woelfel
J. Wright

Subgroup on Welding Qualifications (BPV IX)

T. Melfi, <i>Chair</i>	E. G. Reichelt
A. D. Wilson, <i>Vice Chair</i>	M. J. Rice
K. L. Hayes, <i>Secretary</i>	M. B. Sims
M. Bernasek	W. J. Sperko
M. A. Boring	P. L. Sturgill
D. A. Bowers	J. P. Swezy, Jr.
R. Campbell	C. Violand
R. B. Corbit	D. Chandiramani, <i>Contributing Member</i>
L. S. Harbison	M. Consonni, <i>Contributing Member</i>
M. Heinrichs	M. Dehghan, <i>Contributing Member</i>
J. S. Lee	P. D. Flenner, <i>Contributing Member</i>
W. M. Lundy	T. C. Wiesner, <i>Contributing Member</i>
D. W. Mann	
W. F. Newell, Jr.	

Argentina International Working Group (BPV IX)

A. Burgueno, <i>Chair</i>	M. Favareto
A. R. G. Frinchaboy, <i>Vice Chair</i>	J. A. Gandola
R. Rahaman, <i>Staff Secretary</i>	C. A. Garibotti
M. D. Kuhn, <i>Secretary</i>	J. A. Herrera
B. Bardott	M. A. Mendez
L. F. Boccanera	A. E. Pastor
P. J. Cabot	G. Telleria
J. Caprarulo	M. M. C. Tocco

Germany International Working Group (BPV IX)

A. Roza, <i>Chair</i>	T. Ludwig
A. Spangenberg, <i>Vice Chair</i>	S. Wegener
R. Rahaman, <i>Staff Secretary</i>	F. Wodke
P. Chavadarov	J. Daldrup, <i>Contributing Member</i>
B. Daume	E. Floer, <i>Contributing Member</i>
J. Fleischfresser	R. Helmholdt, <i>Contributing Member</i>
P. Khwaja	G. Naumann, <i>Contributing Member</i>
S. Krebs	K.-G. Toelle, <i>Contributing Member</i>

Italy International Working Group (BPV IX)

D. D. Raimander, <i>Chair</i>	L. Moracchioli
F. Ferrarese, <i>Vice Chair</i>	P. Pacor
R. Rahaman, <i>Staff Secretary</i>	P. Siboni
M. Bernasek	V. Calo, <i>Contributing Member</i>
A. Camanni	G. Gobbi, <i>Contributing Member</i>
P. L. Dinelli	A. Gusmaroli, <i>Contributing Member</i>
M. Mandina	G. Pontiggia, <i>Contributing Member</i>
A. S. Monastra	

Spain International Working Group (BPV IX)

F. J. Q. Pandelo, <i>Chair</i>	F. Manas
F. L. Villabrille, <i>Vice Chair</i>	B. B. Miguel
R. Rahaman, <i>Staff Secretary</i>	A. D. G. Munoz
F. R. Hermida, <i>Secretary</i>	A. B. Pascual
C. A. Celimendiz	S. Sevil
M. A. F. Garcia	G. Gobbi, <i>Contributing Member</i>
R. G. Garcia	

COMMITTEE ON FIBER-REINFORCED PLASTIC PRESSURE VESSELS (BPV X)

B. Linnemann, <i>Chair</i>	D. H. McCauley
D. Eisberg, <i>Vice Chair</i>	N. L. Newhouse
P. D. Stumpf, <i>Staff Secretary</i>	G. Ramirez
A. L. Beckwith	J. R. Richter
F. L. Brown	B. F. Shelley
J. L. Bustillos	G. A. Van Beek
B. R. Colley	S. L. Wagner
T. W. Cowley	D. O. Yancey, Jr.
I. L. Dinovo	P. H. Ziehl
J. Eihusen	D. H. Hodgkinson, <i>Contributing Member</i>
M. R. Gorman	D. L. Keeler, <i>Contributing Member</i>
B. Hebb	
L. E. Hunt	

COMMITTEE ON NUCLEAR INSERVICE INSPECTION (BPV XI)

R. W. Swayne, <i>Chair</i>	T. Nuoffer
D. W. Lamond, <i>Vice Chair</i>	J. Nygaard
A. T. Roberts III, <i>Vice Chair</i>	J. E. O'Sullivan
D. Miro-Quesada, <i>Staff Secretary</i>	N. A. Palm
J. F. Ball	G. C. Park
W. H. Bamford	D. A. Scarth
M. L. Benson	F. J. Schaaf, Jr.
J. M. Boughman	S. Takaya
C. Brown	D. Vetter
S. B. Brown	T. V. Vo
T. L. Chan	J. G. Weicks
R. C. Cipolla	M. Weis
D. R. Cordes	Y.-K. Chung, <i>Delegate</i>
H. Do	C. Ye, <i>Delegate</i>
E. V. Farrell, Jr.	B. Lin, <i>Alternate</i>
M. J. Ferlisi	R. O. McGill, <i>Alternate</i>
T. J. Griesbach	L. A. Melder, <i>Alternate</i>
J. Hakii	A. Udyawar, <i>Alternate</i>
M. L. Hall	E. B. Gerlach, <i>Contributing Member</i>
P. J. Hennessey	C. D. Cowfer, <i>Honorary Member</i>
D. O. Henry	R. E. Gimple, <i>Honorary Member</i>
K. Hojo	F. E. Gregor, <i>Honorary Member</i>
S. D. Kulat	R. D. Kerr, <i>Honorary Member</i>
C. Latiolais	P. C. Riccardella, <i>Honorary Member</i>
J. T. Lindberg	R. A. West, <i>Honorary Member</i>
H. Malikowski	C. J. Wirtz, <i>Honorary Member</i>
S. L. McCracken	R. A. Yonekawa, <i>Honorary Member</i>
S. A. Norman	

Executive Committee (BPV XI)

D. W. Lamond, <i>Chair</i>	S. L. McCracken
R. W. Swayne, <i>Vice Chair</i>	T. Nuoffer
D. Miro-Quesada, <i>Staff Secretary</i>	N. A. Palm
M. L. Benson	G. C. Park
M. J. Ferlisi	A. T. Roberts III
S. D. Kulat	B. L. Lin, <i>Alternate</i>
J. T. Lindberg	

Argentina International Working Group (BPV XI)

O. Martinez, <i>Staff Secretary</i>	F. J. Schaaf, Jr.
A. Claus	F. M. Schroeter
I. M. Guerreiro	P. Yamamoto
L. R. Miño	

China International Working Group (BPV XI)

J. H. Liu, <i>Chair</i>	S. Shuo
J. F. Cai, <i>Vice Chair</i>	Y. Sixin
C. Ye, <i>Vice Chair</i>	Y. X. Sun
M. W. Zhou, <i>Secretary</i>	G. X. Tang
H. Chen	Q. Wang
H. D. Chen	Q. W. Wang
Y. Cheng	Z. S. Wang
Y. B. Guo	L. Xing
Y. Hongqi	F. Xu
D. R. Horn	S. X. Xu
Y. Hou	Q. Yin
S. X. Lin	K. Zhang
Y. Nie	Y. Zhe
W. N. Pei	Z. M. Zhong
L. Shiwei	

Germany International Working Group (BPV XI)

R. Döring, <i>Chair</i>	N. Legl
M. Hagenbruch, <i>Vice Chair</i>	T. Ludwig
R. Piel, <i>Secretary</i>	X. Pitoiset
A. Casse	M. Reichert
C. G. Frantescu	L. Sybertz
E. Iacopetta	I. Tewes
S. D. Kulat	R. Tiete
H.-W. Lange	J. Wendt

India International Working Group (BPV XI)

S. B. Parkash, <i>Chair</i>	N. Palm
D. Narain, <i>Vice Chair</i>	D. Rawal
K. K. Rai, <i>Secretary</i>	R. Sahai
Z. M. Mansuri	R. K. Sharma
M. R. Nadgouda	

Special Working Group on Editing and Review (BPV XI)

R. W. Swayne, <i>Chair</i>	M. Orihuela
R. C. Cipolla	D. A. Scarth
D. O. Henry	

Task Group on Inspectability (BPV XI)

J. T. Lindberg, <i>Chair</i>	J. Honcharik
E. Henry, <i>Secretary</i>	C. Latiolais
A. Bushmire	G. A. Lofthus
A. Cardillo	S. Matsumoto
K. Caver	D. E. Matthews
D. R. Cordes	P. J. O'Regan
P. Gionta	J. B. Ossmann
D. O. Henry	C. Thomas

Working Group on Spent Nuclear Fuel Storage and Transportation Containment Systems (BPV XI)

K. Hunter, <i>Chair</i>	K. Mauskar
M. Orihuela, <i>Secretary</i>	R. M. Meyer
D. J. Ammerman	R. M. Pace
W. H. Bortor	E. L. Pleins
J. Broussard	M. A. Richter
C. R. Bryan	B. Sarno
T. Carraher	R. Sindelar
S. Corcoran	M. Staley
D. Dunn	J. Wellwood
N. Fales	K. A. Whitney
R. C. Folley	X. J. Zhai
G. Grant	P.-S. Lam, <i>Alternate</i>
B. Gutherman	G. White, <i>Alternate</i>
M. W. Joseph	J. Wise, <i>Alternate</i>
M. Keene	H. Smith, <i>Contributing Member</i>
M. Liu	

Task Group on Mitigation and Repair of Spent Nuclear Fuel Canisters (WG-SNFS & TCS) (BPV XI)

J. Tatman, <i>Chair</i>	M. Kris
D. J. Ammerman	M. Liu
J. Broussard	K. Mauskar
C. R. Bryan	S. L. McCracken
G. R. Cannell	M. Orihuela
K. Dietrich	M. Richter
D. Dunn	K. E. Ross
N. Fales	B. Sarno
R. C. Folley	R. Sindelar
D. Jacobs	J. Wellwood
N. Klymyshyn	A. Williams

Subgroup on Evaluation Standards (SG-ES) (BPV XI)

N. A. Palm, <i>Chair</i>	Y. S. Li
S. X. Xu, <i>Secretary</i>	R. O. McGill
W. H. Bamford	K. Miyazaki
M. Brumovsky	R. M. Pace
H. D. Chung	J. C. Poehler
R. C. Cipolla	S. Ranganath
C. M. Faidy	D. A. Scarth
M. M. Farooq	D. J. Shim
B. R. Ganta	A. Udyawar
T. J. Griesbach	T. V. Vo
K. Hasegawa	G. M. Wilkowski
K. Hojo	M. L. Benson, <i>Alternate</i>
D. N. Hopkins	H. S. Mehta, <i>Contributing Member</i>
D. R. Lee	

Task Group on Evaluation of Beyond Design Basis Events (SG-ES) (BPV XI)

R. M. Pace, <i>Chair</i>	K. Hojo
S. X. Xu, <i>Secretary</i>	S. A. Kleinsmith
F. G. Abatt	S. M. Moenssens
G. A. Antaki	T. V. Vo
P. R. Donavin	G. M. Wilkowski
R. G. Gilada	H. S. Mehta, <i>Contributing Member</i>
T. J. Griesbach	T. Weaver, <i>Contributing Member</i>
M. Hayashi	

**Working Group on Flaw Evaluation
(SG-ES) (BPV XI)**

R. C. Cipolla, <i>Chair</i>	Y. S. Li
S. X. Xu, <i>Secretary</i>	C. Liu
W. H. Bamford	M. Liu
M. L. Benson	G. A. Miessi
M. Brumovsky	K. Miyazaki
H. D. Chung	S. Noronha
N. G. Cofie	R. K. Qashu
M. A. Erickson	S. Ranganath
C. M. Faidy	D. A. Scarth
M. M. Farooq	W. L. Server
B. R. Ganta	D. J. Shim
R. G. Gilada	S. Smith
C. Guzman-Leong	M. Uddin
P. H. Hoang	A. Udyawar
K. Hojo	T. V. Vo
D. N. Hopkins	K. Wang
S. Kalyanam	B. Wasiluk
Y. Kim	G. M. Wilkowski
V. Lacroix	H. S. Mehta, <i>Contributing Member</i>
D. R. Lee	

**Working Group on Flaw Evaluation Reference Curves
(SG-ES) (BPV XI)**

A. Udyawar, <i>Chair</i>	V. Lacroix
D. A. Scarth, <i>Secretary</i>	K. Miyazaki
W. H. Bamford	B. Pellereau
M. L. Benson	S. Ranganath
F. W. Brust	D. J. Shim
R. C. Cipolla	S. Smith
M. M. Farooq	M. Uddin
A. E. Freed	T. V. Vo
P. Gill	G. White
K. Hasegawa	S. X. Xu
K. Hojo	H. S. Mehta, <i>Contributing Member</i>

Working Group on Operating Plant Criteria (SG-ES) (BPV XI)

N. A. Palm, <i>Chair</i>	A. D. Odell
A. E. Freed, <i>Secretary</i>	R. M. Pace
W. H. Bamford	J. C. Poehler
M. Brumovsky	S. Ranganath
M. A. Erickson	W. L. Server
T. J. Griesbach	C. A. Tomes
M. Hayashi	A. Udyawar
R. Janowiak	T. V. Vo
M. Kirk	H. Q. Xu
S. A. Kleinsmith	H. S. Mehta, <i>Contributing Member</i>
H. Kobayashi	

Task Group on Appendix L (WG-OPC) (BPV XI)

N. Glunt, <i>Chair</i>	C.-S. Oh
R. M. Pace, <i>Secretary</i>	H. Park
J. I. Duo	S. Ranganath
A. E. Freed	A. Scott
M. A. Gray	D. J. Shim
T. J. Griesbach	S. Smith
H. Nam	A. Udyawar
A. Nana	T. V. Vo
A. D. Odell	

Working Group on Pipe Flaw Evaluation (SG-ES) (BPV XI)

D. A. Scarth, <i>Chair</i>	Y. Kim
S. Kalyanam, <i>Secretary</i>	V. Lacroix
K. Azuma	Y. S. Li
W. H. Bamford	R. O. McGill
M. L. Benson	G. A. Miessi
M. Brumovsky	K. Miyazaki
F. W. Brust	S. M. Parker
H. D. Chung	S. H. Pellet
R. C. Cipolla	C. J. Sallaberry
N. G. Cofie	W. L. Server
C. M. Faidy	D. J. Shim
M. M. Farooq	S. Smith
B. R. Ganta	M. F. Uddin
R. G. Gilada	A. Udyawar
S. R. Gosselin	T. V. Vo
C. E. Guzman-Leong	K. Wang
K. Hasegawa	B. Wasiluk
P. H. Hoang	G. M. Wilkowski
K. Hojo	S. X. Xu
D. N. Hopkins	Y. Zou
E. J. Houston	K. Gresh, <i>Alternate</i>
R. Janowiak	H. S. Mehta, <i>Contributing Member</i>
K. Kashima	

Task Group on Code Case N-513 (WG-PFE) (BPV XI)

R. O. McGill, <i>Chair</i>	E. J. Houston
S. M. Parker, <i>Secretary</i>	R. Janowiak
G. A. Antaki	S. H. Pellet
R. C. Cipolla	D. Rudland
M. M. Farooq	D. A. Scarth
K. Gresh	S. X. Xu

**Task Group on Evaluation Procedures for Degraded Buried Pipe
(WG-PFE) (BPV XI)**

R. O. McGill, <i>Chair</i>	R. Janowiak
S. X. Xu, <i>Secretary</i>	M. Kassar
F. G. Abatt	M. Moenssens
G. A. Antaki	D. P. Munson
R. C. Cipolla	R. M. Pace
R. G. Gilada	S. H. Pellet
K. Hasegawa	D. Rudland
K. M. Hoffman	D. A. Scarth

Task Group on Flaw Evaluation for HDPE Pipe (WG-PFE) (BPV XI)

S. Kalyanam, <i>Chair</i>	D. J. Shim
P. Krishnaswamy	M. Troughton
M. Moenssens	J. Wright
D. P. Munson	S. X. Xu
D. A. Scarth	

Subgroup on Nondestructive Examination (SG-NDE) (BPV XI)

J. T. Lindberg, <i>Chair</i>	S. E. Cumblidge
D. O. Henry, <i>Vice Chair</i>	K. J. Hacker
T. Cinson, <i>Secretary</i>	J. Harrison
M. Briley	D. A. Kull
C. Brown	C. Latiolais
A. Bushmire	F. J. Schaaf, Jr.
T. L. Chan	R. V. Swain
D. R. Cordes	C. A. Nove, <i>Alternate</i>

Working Group on Personnel Qualification and Surface Visual and Eddy Current Examination (SG-NDE) (BPV XI)

C. Brown, *Chair*
M. Orihuela, *Secretary*
J. Bennett
T. Cinson
S. E. Cumblidge
A. Diaz
N. Farenbaugh

D. O. Henry
J. T. Lindberg
C. Shinsky
R. Tedder
T. Thulien
J. T. Timm

Working Group on Procedure Qualification and Volumetric Examination (SG-NDE) (BPV XI)

J. Harrison, *Chair*
D. A. Kull, *Secretary*
M. Briley
A. Bushmire
D. R. Cordes
K. J. Hacker
R. E. Jacob
W. A. Jensen

C. Latiolais
C. A. Nove
D. R. Slivon
R. V. Swain
D. Van Allen
J. Williams
B. Lin, *Alternate*

Subgroup on Reliability and Integrity Management Program (SG-RIM) (BPV XI)

A. T. Roberts III, *Chair*
D. Vetter, *Secretary*
T. Anselmi
M. T. Audrain
N. Broom
F. W. Brust
V. Chugh
S. R. Doctor
J. D. Fletcher
J. T. Fong
R. Grantom
K. Harris

P. J. Hennessey
S. Kalyanam
D. R. Lee
R. J. McReynolds
R. Meyer
M. Orihuela
C. J. Sallaberry
F. J. Schaaf, Jr.
H. M. Stephens, Jr.
R. W. Swayne
S. Takaya
R. Vayda

Working Group on MANDE (SG-RIM) (BPV XI)

H. M. Stephens, Jr., *Chair*
S. R. Doctor, *Vice Chair*
M. Turnbow, *Secretary*
T. Anselmi
M. T. Audrain
N. A. Finney

J. T. Fong
D. O. Henry
R. J. McReynolds
R. Meyer
M. Orihuela
K. Yamada

Task Group on Nonmetallic Component Degradation and Failure Monitoring (SG-RIM) (BPV XI)

M. P. Metcalfe, *Chair*
A. Tzelepi, *Secretary*
M. T. Audrain
G. Beirnaert
C. Chen

W. J. Geringer
K. Harris
J. Lang
J. Potgieter

ASME/JSME Joint Working Group on RIM Processes and System-Based Code (SG-RIM) (BPV XI)

S. Takaya, *Chair*
R. J. McReynolds, *Vice Chair*
M. T. Audrain
K. Dozaki
J. T. Fong
J. Hakii
K. Harris
M. Hayashi
S. Kalyanam
D. R. Lee
H. Machida

R. Meyer
T. Muraki
S. Okajima
A. T. Roberts III
C. J. Sallaberry
F. J. Schaaf, Jr.
R. Vayda
D. Watanabe
H. Yada
K. Yamada
T. Asayama, *Contributing Member*

Subgroup on Repair/Replacement Activities (SG-RRA) (BPV XI)

S. L. McCracken, *Chair*
E. V. Farrell, Jr., *Secretary*
J. F. Ball
M. Brandes
S. B. Brown
R. Clow
S. J. Findlan
M. L. Hall
J. Honcharik
A. B. Meichler

L. A. Melder
S. A. Norman
G. T. Olson
J. E. O'Sullivan
G. C. Park
R. R. Stevenson
R. W. Swayne
D. J. Tilly
J. G. Weicks
B. Lin, *Alternate*

Working Group on Design and Programs (SG-RRA) (BPV XI)

S. B. Brown, *Chair*
R. A. Patel, *Secretary*
O. Bhatti
R. Clow
R. R. Croft
E. V. Farrell, Jr.
K. Harris
B. Lin

H. Malikowski
A. B. Meichler
G. C. Park
M. A. Pyne
R. R. Stevenson
K. Sullivan
R. W. Swayne

Task Group on Repair and Replacement Optimization (WG-D&P) (BPV XI)

S. L. McCracken, *Chair*
S. J. Findlan, *Secretary*
T. Basso
R. Clow
K. Dietrich
E. V. Farrell, Jr.
M. J. Ferlisi
R. C. Folley

M. L. Hall
D. Jacobs
H. Malikowski
T. Nuoffer
G. C. Park
A. Patel
R. R. Stevenson
J. G. Weicks

Working Group on Nonmetals Repair/Replacement Activities (SG-RRA) (BPV XI)

J. E. O'Sullivan, *Chair*
S. Schuessler, *Secretary*
M. Brandes
D. R. Dechene
M. Golliet
J. Johnston, Jr.
B. Lin

T. M. Musto
A. Pridmore
F. J. Schaaf, Jr.
R. Stakenborghs
P. Vibien
M. P. Marohl, *Contributing Member*

**Task Group on HDPE Piping for Low Safety Significance Systems
(WG-NMRRA) (BPV XI)**

M. Brandes, *Chair*
J. E. O'Sullivan, *Secretary*
M. Golliet
B. Lin

T. M. Musto
F. J. Schaaf, Jr.
S. Schuessler
R. Stakenborghs

**Task Group on Repair by Carbon Fiber Composites
(WG-NMRRA) (BPV XI)**

J. E. O'Sullivan, *Chair*
S. F. Arnold
S. W. Choi
D. R. Dechene
M. Golliet
L. S. Gordon
P. Krishnaswamy
M. Kuntz
H. Lu
M. P. Marohl
L. Nadeau

C. A. Nove
R. P. Ojdrovic
A. Pridmore
S. Rios
C. W. Rowley
J. Sealey
R. Stakenborghs
N. Stoeva
M. F. Uddin
J. Wen
B. Davenport, *Alternate*

**Working Group on Welding and Special Repair Processes
(SG-RRR) (BPV XI)**

J. G. Weicks, *Chair*
G. T. Olson, *Secretary*
D. Barborak
S. J. Findlan
R. C. Folley
M. L. Hall
J. Honcharik

D. Jacobs
M. Kris
S. E. Marlette
S. L. McCracken
L. A. Melder
J. E. O'Sullivan
D. J. Tilly

Task Group on Temper Bead Welding (WG-W&SRP) (BPV XI)

S. J. Findlan, *Chair*
D. Barborak
R. C. Folley
J. Graham
M. L. Hall
D. Jacobs
H. Kobayashi

S. L. McCracken
N. Mohr
G. T. Olson
J. E. O'Sullivan
A. Patel
J. Tatman
J. G. Weicks

Task Group on Weld Overlay (WG-W&SRP)(BPV XI)

S. L. McCracken, *Chair*
S. Hunter, *Secretary*
D. Barborak
S. J. Findlan
J. Graham
M. L. Hall
D. Jacobs

C. Lohse
S. E. Marlette
G. T. Olson
A. Patel
D. W. Sandusky
D. E. Waskey
J. G. Weicks

Subgroup on Water-Cooled Systems (SG-WCS) (BPV XI)

M. J. Ferlisi, *Chair*
J. Nygaard, *Secretary*
J. M. Boughman
S. T. Chesworth
J. Collins
H. Q. Do
K. W. Hall
P. J. Hennessey
A. E. Keyser

S. D. Kulat
D. W. Lamond
T. Nomura
T. Nuoffer
M. A. Pyne
H. M. Stephens, Jr.
R. Thames
M. Weis
I. A. Anchondo-Lopez, *Alternate*

Task Group on High Strength Nickel Alloys Issues (SG-WCS) (BPV XI)

H. Malikowski, *Chair*
C. Waskey, *Secretary*
E. Blackard
T. Cinson
J. Collins
K. Dietrich
P. R. Donavin

H. Kobayashi
S. E. Marlette
G. C. Park
C. Wax
G. White
K. A. Whitney

Working Group on Containment (SG-WCS) (BPV XI)

M. J. Ferlisi, *Chair*
R. Thames, *Secretary*
P. S. Ghosal
H. T. Hill
S. Johnson
A. E. Keyser
B. Lehman

P. Leiningar
J. A. Munshi
M. Sircar
P. C. Smith
S. Walden
M. Weis
S. G. Brown, *Alternate*

**Working Group on Inspection of Systems and Components
(SG-WCS) (BPV XI)**

H. Q. Do, *Chair*
M. Weis, *Secretary*
I. A. Anchondo-Lopez
R. W. Blyde
K. Caver
C. Cueto-Felgueroso
M. J. Ferlisi
M. L. Garcia Heras
K. W. Hall

J. Howard
A. Keller
S. D. Kulat
E. Lantz
A. Maekawa
T. Nomura
J. C. Nygaard
S. Orita
A. W. Wilkens

Working Group on Pressure Testing (SG-WCS) (BPV XI)

J. M. Boughman, *Chair*
S. A. Norman, *Secretary*
T. Anselmi
M. J. Homiack
A. E. Keyser

D. W. Lamond
M. Moenssens
R. A. Nettles
C. Thomas
K. Whitney

Working Group on Risk-Informed Activities (SG-WCS) (BPV XI)

M. A. Pyne, *Chair*
S. T. Chesworth, *Secretary*
G. Brouette
C. Cueto-Felgueroso
R. Haessler
J. Hakii
K. W. Hall

M. J. Homiack
S. D. Kulat
D. W. Lamond
E. Lantz
P. J. O'Regan
N. A. Palm
D. Vetter

Working Group on General Requirements (BPV XI)

T. Nuoffer, *Chair*
J. Mayo, *Secretary*
J. F. Ball
T. L. Chan
P. J. Hennessey
K. A. Kavanagh
G. Ramaraj

T. N. Rezk
A. T. Roberts III
S. R. Scott
D. Vetter
S. E. Woolf
B. Harris, *Alternate*
R. S. Spencer, *Alternate*

COMMITTEE ON TRANSPORT TANKS (BPV XII)

N. J. Paulick, <i>Chair</i>	M. Pitts
M. D. Rana, <i>Vice Chair</i>	J. Roberts
J. Oh, <i>Staff Secretary</i>	T. A. Rogers
A. N. Antoniou	R. C. Sallash
K. W. A. Cheng	M. Shah
P. Chilukuri	S. Staniszewski
W. L. Garfield	A. P. Varghese
P. Miller	R. Meyers, <i>Contributing Member</i>

Executive Committee (BPV XII)

M. D. Rana, <i>Chair</i>	T. A. Rogers
N. J. Paulick, <i>Vice Chair</i>	R. C. Sallash
J. Oh, <i>Staff Secretary</i>	S. Staniszewski
M. Pitts	A. P. Varghese

Subgroup on Design and Materials (BPV XII)

R. C. Sallash, <i>Chair</i>	S. Staniszewski
D. K. Chandiramani	A. P. Varghese
K. W. A. Cheng	K. Xu
P. Chilukuri	Y. Doron, <i>Contributing Member</i>
S. L. McWilliams	A. T. Duggleby, <i>Contributing Member</i>
N. J. Paulick	R. D. Hayworth, <i>Contributing Member</i>
M. D. Rana	B. E. Spencer, <i>Contributing Member</i>
T. J. Rishel	J. Zheng, <i>Contributing Member</i>
T. A. Rogers	
M. Shah	

Subgroup on Fabrication, Inspection, and Continued Service (BPV XII)

M. Pitts, <i>Chair</i>	T. A. Rogers
K. W. A. Cheng	R. C. Sallash
P. Chilukuri	S. Staniszewski
M. Koprivnak	Y. Doron, <i>Contributing Member</i>
P. Miller	R. D. Hayworth, <i>Contributing Member</i>
O. Mulet	G. McRae, <i>Contributing Member</i>
T. J. Rishel	
J. Roberts	

Subgroup on General Requirements (BPV XII)

S. Staniszewski, <i>Chair</i>	M. Pitts
A. N. Antoniou	R. C. Sallash
P. Chilukuri	Y. Doron, <i>Contributing Member</i>
H. Ebben III	T. J. Hitchcock, <i>Contributing Member</i>
J. L. Freiler	S. L. McWilliams, <i>Contributing Member</i>
W. L. Garfield	T. A. Rogers, <i>Contributing Member</i>
O. Mulet	D. G. Shelton, <i>Contributing Member</i>
B. F. Pittel	

Subgroup on Nonmandatory Appendices (BPV XII)

T. A. Rogers, <i>Chair</i>	R. C. Sallash
S. Staniszewski, <i>Secretary</i>	D. G. Shelton
P. Chilukuri	D. D. Brusewitz, <i>Contributing Member</i>
N. J. Paulick	Y. Doron, <i>Contributing Member</i>
M. Pitts	
T. J. Rishel	

COMMITTEE ON OVERPRESSURE PROTECTION (BPV XIII)

B. K. Nutter, <i>Chair</i>	R. W. Barnes, <i>Contributing Member</i>
A. Donaldson, <i>Vice Chair</i>	R. D. Danzy, <i>Contributing Member</i>
C. E. Rodrigues, <i>Staff Secretary</i>	A. Frigerio, <i>Contributing Member</i>
J. F. Ball	J. P. Gaspie, <i>Contributing Member</i>
J. Burgess	S. F. Harrison, Jr., <i>Contributing Member</i>
B. Calderon	A. Hassan, <i>Contributing Member</i>
D. B. DeMichael	P. K. Lam, <i>Contributing Member</i>
J. W. Dickson	M. Mengon, <i>Contributing Member</i>
J. M. Levy	J. Mize, <i>Contributing Member</i>
D. Miller	M. Mullavey, <i>Contributing Member</i>
T. Patel	S. K. Parimi, <i>Contributing Member</i>
B. F. Pittel	J. Phillips, <i>Contributing Member</i>
T. R. Tarbay	M. Reddy, <i>Contributing Member</i>
D. E. Tompkins	S. Ruesenberg, <i>Contributing Member</i>
Z. Wang	K. Shores, <i>Contributing Member</i>
J. A. West	D. E. Tezzo, <i>Contributing Member</i>
B. Engman, <i>Alternate</i>	A. Wilson, <i>Contributing Member</i>
H. Aguilar, <i>Contributing Member</i>	

Executive Committee (BPV XIII)

A. Donaldson, <i>Chair</i>	D. B. DeMichael
B. K. Nutter, <i>Vice Chair</i>	K. R. May
C. E. Rodrigues, <i>Staff Secretary</i>	D. Miller
J. F. Ball	

Subgroup on Design and Materials (BPV XIII)

D. Miller, <i>Chair</i>	J. A. West
T. Patel, <i>Vice Chair</i>	A. Williams
T. K. Acharya	D. J. Azukas, <i>Contributing Member</i>
C. E. Beair	R. D. Danzy, <i>Contributing Member</i>
W. E. Chapin	A. Hassan, <i>Contributing Member</i>
J. L. Freiler	R. Miyata, <i>Contributing Member</i>
B. Joergensen	M. Mullavey, <i>Contributing Member</i>
V. Kalyanasundaram	S. K. Parimi, <i>Contributing Member</i>
R. Krithivasan	G. Ramirez, <i>Contributing Member</i>
B. J. Mollitor	K. Shores, <i>Contributing Member</i>
T. R. Tarbay	

Subgroup on General Requirements (BPV XIII)

A. Donaldson, *Chair*
 B. F. Pittel, *Vice Chair*
 J. M. Levy, *Secretary*
 R. Antoniuk
 D. J. Azukas
 J. F. Ball
 J. Burgess
 D. B. DeMichael
 S. T. French
 J. Grace
 C. Haldiman
 J. Horne
 R. Klimas, Jr.
 Z. E. Kumana
 P. K. Lam
 D. Mainiero-Cessna
 K. R. May
 J. Mize
 L. Moedinger
 M. Mullavey
 K. Shores

D. E. Tezzo
 D. E. Tompkins
 J. F. White
 B. Calderon, *Contributing Member*
 P. Chavdarov, *Contributing Member*
 T. M. Fabiani, *Contributing Member*
 J. L. Freiler, *Contributing Member*
 J. P. Glaspie, *Contributing Member*
 G. D. Goodson, *Contributing Member*
 B. Joergensen, *Contributing Member*
 C. Lasarte, *Contributing Member*
 M. Mengon, *Contributing Member*
 D. E. Miller, *Contributing Member*
 R. Miyata, *Contributing Member*
 B. Mruk, *Contributing Member*
 J. Phillips, *Contributing Member*
 M. Reddy, *Contributing Member*
 S. Ruesenberg, *Contributing Member*
 R. Sadowski, *Contributing Member*
 A. Swearingin, *Contributing Member*
 A. P. Varghese, *Contributing Member*

Subgroup on Nuclear (BPV XIII)

K. R. May, *Chair*
 J. F. Ball, *Vice Chair*
 R. Krithivasan, *Secretary*
 M. Brown
 J. W. Dickson
 S. Jones
 R. Lack
 D. Miller
 T. Patel

K. Shores
 I. H. Tseng
 B. J. Yonsky
 J. M. Levy, *Alternate*
 Y. Wong, *Alternate*
 J. Yu, *Alternate*
 S. T. French, *Contributing Member*
 D. B. Ross, *Contributing Member*

Subgroup on Testing (BPV XIII)

B. K. Nutter, *Chair*
 J. W. Dickson, *Vice Chair*
 R. Houk, *Secretary*
 T. P. Beirne
 M. Brown
 B. Calderon
 V. Chicola III
 B. Engman
 R. J. Garnett
 R. Lack
 M. Mengon

C. Sharpe
 J. R. Thomas, Jr.
 Z. Wang
 D. Nelson, *Alternate*
 J. Mize, *Contributing Member*
 M. Mullavey, *Contributing Member*
 S. Ruesenberg, *Contributing Member*
 K. Shores, *Contributing Member*
 A. Streckler, *Contributing Member*
 A. Wilson, *Contributing Member*

US TAG to ISO TC 185 Safety Devices for Protection Against Excessive Pressure (BPV XIII)

D. Miller, *Chair*
 C. E. Rodrigues, *Staff Secretary*
 J. F. Ball
 T. J. Bevilacqua
 D. B. DeMichael
 J. W. Dickson

B. K. Nutter
 T. Patel
 J. R. Thomas, Jr.
 D. Tuttle
 J. A. West
 J. F. White

COMMITTEE ON BOILER AND PRESSURE VESSEL CONFORMITY ASSESSMENT (CBPVCA)

R. V. Wielgoszinski, *Chair*
 G. Scribner, *Vice Chair*
 G. Moino, *Staff Secretary*
 M. Blankinship
 J. P. Chicoine
 T. E. Hansen
 W. Hibdon
 B. L. Krasiun
 L. E. McDonald
 N. Murugappan
 I. Powell
 D. E. Tuttle
 E. A. Whittle
 P. Williams

T. P. Beirne, *Alternate*
 N. Caputo, *Alternate*
 P. Chavdarov, *Alternate*
 J. M. Downs, *Alternate*
 P. D. Edwards, *Alternate*
 Y.-S. Kim, *Alternate*
 B. Morelock, *Alternate*
 M. Prefumo, *Alternate*
 R. Rockwood, *Alternate*
 K. Roewe, *Alternate*
 B. C. Turczynski, *Alternate*
 J. Yu, *Alternate*
 D. Cheetham, *Contributing Member*
 A. J. Spencer, *Honorary Member*

COMMITTEE ON NUCLEAR CERTIFICATION (CNC)

R. R. Stevenson, *Chair*
 M. A. Lockwood, *Vice Chair*
 S. Khan, *Staff Secretary*
 A. Appleton
 J. F. Ball
 G. Claffey
 N. DeSantis
 C. Dinic
 G. Gobbi
 J. W. Highlands
 K. A. Kavanagh
 J. C. Krane
 T. McGee
 E. L. Pleins
 T. E. Quaka
 T. N. Rezk
 D. M. Vickery
 E. A. Whittle

T. Aldo, *Alternate*
 M. Blankinship, *Alternate*
 G. Brouette, *Alternate*
 M. Burke, *Alternate*
 P. J. Coco, *Alternate*
 Y. Diaz-Castillo, *Alternate*
 P. D. Edwards, *Alternate*
 J. Grimm, *Alternate*
 K. M. Hottle, *Alternate*
 P. Krane, *Alternate*
 S. J. Montano, *Alternate*
 I. Olson, *Alternate*
 L. Ponce, *Alternate*
 M. Wilson, *Alternate*
 S. Yang, *Alternate*
 S. F. Harrison, Jr., *Contributing Member*

CORRESPONDENCE WITH THE COMMITTEE

(23)

General

ASME codes and standards are developed and maintained by committees with the intent to represent the consensus of concerned interests. Users of ASME codes and standards may correspond with the committees to propose revisions or cases, report errata, or request interpretations. Correspondence for this Section of the ASME Boiler and Pressure Vessel Code (BPVC) should be sent to the staff secretary noted on the Section's committee web page, accessible at <https://go.asme.org/CSCcommittees>.

NOTE: See ASME BPVC Section II, Part D for guidelines on requesting approval of new materials. See Section II, Part C for guidelines on requesting approval of new welding and brazing materials ("consumables").

Revisions and Errata

The committee processes revisions to this Code on a continuous basis to incorporate changes that appear necessary or desirable as demonstrated by the experience gained from the application of the Code. Approved revisions will be published in the next edition of the Code.

In addition, the committee may post errata and Special Notices at <http://go.asme.org/BPVCerrata>. Errata and Special Notices become effective on the date posted. Users can register on the committee web page to receive e-mail notifications of posted errata and Special Notices.

This Code is always open for comment, and the committee welcomes proposals for revisions. Such proposals should be as specific as possible, citing the paragraph number(s), the proposed wording, and a detailed description of the reasons for the proposal, including any pertinent background information and supporting documentation.

Cases

- (a) The most common applications for cases are
 - (1) to permit early implementation of a revision based on an urgent need
 - (2) to provide alternative requirements
 - (3) to allow users to gain experience with alternative or potential additional requirements prior to incorporation directly into the Code
 - (4) to permit use of a new material or process
- (b) Users are cautioned that not all jurisdictions or owners automatically accept cases. Cases are not to be considered as approving, recommending, certifying, or endorsing any proprietary or specific design, or as limiting in any way the freedom of manufacturers, constructors, or owners to choose any method of design or any form of construction that conforms to the Code.
- (c) The committee will consider proposed cases concerning the following topics only:
 - (1) equipment to be marked with the ASME Single Certification Mark, or
 - (2) equipment to be constructed as a repair/replacement activity under the requirements of Section XI
- (d) A proposed case shall be written as a question and reply in the same format as existing cases. The proposal shall also include the following information:
 - (1) a statement of need and background information
 - (2) the urgency of the case (e.g., the case concerns a project that is underway or imminent)
 - (3) the Code Section and the paragraph, figure, or table number(s) to which the proposed case applies
 - (4) the edition(s) of the Code to which the proposed case applies
- (e) A case is effective for use when the public review process has been completed and it is approved by the cognizant supervisory board. Cases that have been approved will appear in the next edition or supplement of the Code Cases books, "Boilers and Pressure Vessels" or "Nuclear Components." Each Code Cases book is updated with seven Supplements.

Supplements will be sent or made available automatically to the purchasers of the Code Cases books until the next edition of the Code. Annulments of Code Cases become effective six months after the first announcement of the annulment in a Code Case Supplement or Edition of the appropriate Code Case book. The status of any case is available at <http://go.asme.org/BPVCCDatabase>. An index of the complete list of Boiler and Pressure Vessel Code Cases and Nuclear Code Cases is available at <http://go.asme.org/BPVCC>.

Interpretations

(a) Interpretations clarify existing Code requirements and are written as a question and reply. Interpretations do not introduce new requirements. If a revision to resolve conflicting or incorrect wording is required to support the interpretation, the committee will issue an intent interpretation in parallel with a revision to the Code.

(b) Upon request, the committee will render an interpretation of any requirement of the Code. An interpretation can be rendered only in response to a request submitted through the online Interpretation Submittal Form at <http://go.asme.org/InterpretationRequest>. Upon submitting the form, the inquirer will receive an automatic e-mail confirming receipt.

(c) ASME does not act as a consultant for specific engineering problems or for the general application or understanding of the Code requirements. If, based on the information submitted, it is the opinion of the committee that the inquirer should seek assistance, the request will be returned with the recommendation that such assistance be obtained. Inquirers may track the status of their requests at <http://go.asme.org/Interpretations>.

(d) ASME procedures provide for reconsideration of any interpretation when or if additional information that might affect an interpretation is available. Further, persons aggrieved by an interpretation may appeal to the cognizant ASME committee or subcommittee. ASME does not “approve,” “certify,” “rate,” or “endorse” any item, construction, proprietary device, or activity.

(e) Interpretations are published in the ASME Interpretations Database at <http://go.asme.org/Interpretations> as they are issued.

Committee Meetings

The ASME BPVC committees regularly hold meetings that are open to the public. Persons wishing to attend any meeting should contact the secretary of the applicable committee. Information on future committee meetings can be found at <http://go.asme.org/BCW>.

PREAMBLE

The rules of this Section of the Code cover minimum construction requirements for the design, fabrication, installation, and inspection of steam heating, hot water heating, and hot water supply boilers that are directly fired with oil, gas, electricity, coal, or other solid or liquid fuels, and for operation at or below the pressure and temperature limits set forth in this document. Similar rules for potable water heaters are also included.

For Section IV application, the boiler proper or other vessels terminate at the supply and return connections to the system or the supply and feedwater connections of a hot water supply boiler. These connections may be any of the following:

- (a) the first circumferential joint for welding end connections
- (b) the face of the first flange in bolted flanged connections
- (c) the first threaded joint in that type of connection

Included within the scope of the boiler are pressure-retaining covers for inspection openings, such as manhole covers, handhold covers, and plugs; and headers required to connect individual coils, tubes, or cast sections within a boiler.

The rules are divided into four major Parts: Part HG, applying to all materials of construction except as provided for in Part HLW; Part HF, applying to assemblies fabricated of wrought material, except as provided for in Part HLW; Part HC, applying to cast iron assemblies; Part HA, applying to boilers constructed of cast aluminum; and Part HLW, applying to potable water heaters. Part HF is further subdivided into Subpart HW, containing rules for welded construction, and Subpart HB, containing rules for brazed construction.

The Parts and Subparts of this Section are divided into Articles. Each Article is given a number and a title, as for example, Part HG, Article 3, Design. Articles are divided into paragraphs that are given a three-digit number, the first of which corresponds to the Article number. Thus, under Article 3 of Part HG, paragraph HG-307 will be found. Paragraphs are further subdivided into subparagraphs. Major subdivisions of paragraphs are designated by three- or four-digit numbers followed by a decimal point and a digit or digits. Where necessary, further subdivisions are represented by letters and then by numbers in parentheses. Minor subdivisions of the paragraphs are also represented by letters. A reference to one of these paragraphs in the text of the Section includes all of the applicable rules in that paragraph. Thus, reference to HG-307 includes all the rules in HG-307.1 through HG-307.4.

This Section does not contain rules to cover all possible details of design and construction. Where complete details are not given, it is intended that the manufacturer, subject to the acceptance of the Authorized Inspector, shall provide details of design and construction that will be as safe as otherwise required by these rules.

When the strength of any part cannot be computed with a satisfactory assurance of safety, these rules provide procedures for establishing its maximum allowable working pressure.

SUMMARY OF CHANGES

Changes listed below are identified on the pages by a margin note, **(23)**, placed next to the affected area.

<i>Page</i>	<i>Location</i>	<i>Change</i>
xiii	List of Sections	(1) Under Section III, Division 4 added (2) Title of Section XI and subtitle of Section XI, Division 2 revised (3) Information on interpretations and Code cases moved to “Correspondence With the Committee”
xvii	Personnel	Updated
xxxix	Correspondence With the Committee	Added (replaces “Submittal of Technical Inquiries to the Boiler and Pressure Vessel Standards Committees”)
xlv	Cross-Referencing in the ASME BPVC	Updated
4	HG-301.2	Subparagraph (d) revised
6	Figure HG-307	Cross-references in sketches (j) and (k) revised
9	HG-307.5	Subparagraph (b) revised
29	HG-360.1	Subparagraph (b) revised
33	Article 4	Deleted
34	HG-401A	Subparagraph (a) revised
34	HG-402A.2	Revised
38	HG-502.2	Subparagraph (d)(2)(-b) revised
39	HG-502.4	Subparagraph (d)(2)(-b) revised
41	HG-511	(1) Former subpara. (c) deleted and subsequent subparagraphs redesignated (2) Subparagraph (e) [formerly (f)] revised
41	HG-515.2	(1) Subparagraphs (d), (n), (o), and (p) revised (2) Subparagraph (q) added
42	HG-515.3	Subparagraph (b)(14) revised
43	HG-520	Revised in its entirety
44	HG-530.1	Subparagraph (g) revised
45	HG-530.2	Subparagraph (g) revised
48	HG-531	Revised in its entirety
49	Figure HG-531.2	In title and figure, “PRT” revised to “PRT IV”
48	HG-532	Revised in its entirety
49	HG-533.1	First sentence revised
49	HG-533.2	Revised
49	HG-533.3	Last sentence revised
49	HG-533.6	Revised
49	HG-533.7	Second sentence revised
50	HG-540.1	First sentence revised
50	HG-540.5	First sentence revised
61	HG-710.2	Subparagraph (b) revised
62	HG-710.4	(1) Former HG-710.5 redesignated as HG-710.4 (2) Subparagraph (d) revised
62	HG-715	Subparagraphs (c) and (d) revised
63	HG-725.6	Second sentence revised
65	HG-801	Revised in its entirety
66	HG-803	Revised in its entirety
69	HF-201	Subparagraph (b)(1) revised
69	HF-203	Revised
69	HF-203.1	First sentence of subpara. (a) revised
70	HF-203.3	Endnote 20 and subpara. (a) revised

Page	Location	Change
73	HF-301.1	Subparagraphs (c) and (d) revised
73	HF-301.2	Subparagraph (b) revised
83	Figure HW-715.1	Revised
90	Figure HW-745	In illustration (f), Step 1 revised
93	HW-820.1	Editorially reformatted
93	HW-820.8	(1) Editorially reformatted (2) Subparagraph (e) [formerly (a)(5)] revised
106	HC-211	In-text table editorially revised
114	HC-403	Revised
116	HC-502.10.1	Revised
116	HC-502.12.2	Subparagraph (b) revised
123	HA-404	Revised
126	HA-502.10.1	Revised
126	HA-502.12.2	Subparagraph (b) revised
132	HLW-200	Subparagraph (k) added
133	HLW-201	Subparagraph (d) added
137	HLW-309	Title and subparas. (a)(1) and (b) revised
137	HLW-310.2	Revised
140	HLW-413	Subparagraph (c) added and subsequent subparagraphs redesignated
149	HLW-451	Subparagraph (b)(5)
154	HLW-504	Second paragraph revised
154	HLW-505.1	Revised
154	HLW-505.2	Added and subsequent paragraph redesignated
156	HLW-601	Revised in its entirety
157	HLW-602	Revised in its entirety
161	HLW-800.1	Subparagraph (c) revised
161	HLW-801.3	Subparagraph (b) added and subsequent paragraph redesignated
162	HLW-801.7	Subparagraph (b) revised
162	HLW-810	Subparagraph (a) revised
165	Article 9	Revised in its entirety
168	Table 2-100	ASME B16.14 deleted by errata
170	Mandatory Appendix 4	Revised
171	Table 4-1	(1) Column for Form H-1 added (2) Instructions for Reference Numbers (4), (23), (28), (29), (30), (40), (54), (55), and (74) revised
174	Form H-1	Added
176	Form H-2	Title and line 4 revised
178	Form H-3	Title and line 4 revised
180	Form H-4	Under "Certificate of Shop Compliance," "PRT" revised to "PRT IV"
182	Form H-5	On back page, Note deleted
184	Form H-5A	On back page, Note deleted
193	Form HLW-6	Title and line 9 revised
195	Form HLW-7	(1) Title editorially revised (2) Under "Certificate of Shop Compliance," "PRT" revised to "PRT IV"
202	7-500	Revised
204	Mandatory Appendix 8	(1) Revised in its entirety (2) Form 8-1 and Table 8-200-1 deleted
207	10-100	Last sentence revised
216	E-100	Added and subsequent paragraphs redesignated
216	E-101	(1) Definition of <i>feedwater</i> revised (2) Definition of <i>valve, pressure relief</i> deleted (3) Definition of <i>valve, relief</i> added
223	Nonmandatory Appendix H	Updated

Page	Location	Change
224	Nonmandatory Appendix K	Under “Description,” “Certification Mark With PRT Designator” revised to “Certification Mark With PRT IV Designator”
231	Nonmandatory Appendix P	Deleted

CROSS-REFERENCING IN THE ASME BPVC

(23)

Paragraphs within the ASME BPVC may include subparagraph breakdowns, i.e., nested lists. The following is a guide to the designation and cross-referencing of subparagraph breakdowns:

(a) Hierarchy of Subparagraph Breakdowns

- (1) First-level breakdowns are designated as (a), (b), (c), etc.
- (2) Second-level breakdowns are designated as (1), (2), (3), etc.
- (3) Third-level breakdowns are designated as (-a), (-b), (-c), etc.
- (4) Fourth-level breakdowns are designated as (-1), (-2), (-3), etc.
- (5) Fifth-level breakdowns are designated as (+a), (+b), (+c), etc.
- (6) Sixth-level breakdowns are designated as (+1), (+2), etc.

(b) Cross-References to Subparagraph Breakdowns. Cross-references within an alphanumerically designated paragraph (e.g., PG-1, UIG-56.1, NCD-3223) do not include the alphanumeric designator of that paragraph. The crossreferences to subparagraph breakdowns follow the hierarchy of the designators under which the breakdown appears. The following examples show the format:

- (1) If X.1(c)(1)(-a) is referenced in X.1(c)(1), it will be referenced as (-a).
- (2) If X.1(c)(1)(-a) is referenced in X.1(c)(2), it will be referenced as (1)(-a).
- (3) If X.1(c)(1)(-a) is referenced in X.1(e)(1), it will be referenced as (c)(1)(-a).
- (4) If X.1(c)(1)(-a) is referenced in X.2(c)(2), it will be referenced as X.1(c)(1)(-a).

INTENTIONALLY LEFT BLANK

PART HG

GENERAL REQUIREMENTS FOR ALL MATERIALS OF CONSTRUCTION

ARTICLE 1

SCOPE AND SERVICE RESTRICTIONS

HG-100 SCOPE

(a) The rules of [Part HG](#) apply to steam heating boilers, hot water heating boilers, hot water supply boilers, and to appurtenances thereto. They shall be used in conjunction with the specific requirements in [Part HF](#) (boilers of wrought materials), [Part HC](#) (cast iron boilers), and [Part HA](#) (cast aluminum boilers), as applicable. The Foreword provides the basis for these rules. [Part HG](#) is not intended to apply to potable water heaters except as provided for in [Part HLW](#). Boilers with economizers shall follow the rules of Mandatory [Appendix 10](#).

(b) This Part contains mandatory requirements, specific prohibitions, and nonmandatory guidance for materials, designs, fabrication, examination, inspection, testing, certification, and overpressure protection. When detailed rules are not given in Section IV, the Manufacturer, subject to the acceptance of the Authorized Inspector, shall provide details of design that will be as safe as those provided by the rules of Section IV. This may be done by appropriate analytical methods, the appropriate use of rules from other design Codes or, as permitted in [HG-500](#), by proof test.

(c) The Manufacturer shall establish the effective Code edition, addenda, and cases in accordance with [Mandatory Appendix 9](#). Laws or regulations issued by a municipality, state, provincial, federal, or other enforcement or regulatory body having jurisdiction at the location of an installation, establish the mandatory applicability of these rules, in whole or in part.

HG-101 SERVICE RESTRICTIONS

HG-101.1 Service Restrictions. The rules of this Section are restricted to the following services:

(a) steam boilers for operation at pressures not exceeding 15 psi (100 kPa)

(b) hot water heating boilers and hot water supply boilers for operation at pressures not exceeding 160 psi (1 100 kPa)

(c) hot water heating boilers and hot water supply boilers for operation at temperatures not exceeding 250°F (120°C), at or near the boiler outlet, except that when some of the wrought materials permitted by [Part HF](#) are used, a lower temperature is specified

HG-101.2 Services in Excess of Those Covered by This Section. For services exceeding the limits specified in [HG-101.1](#), the rules of Section I shall apply.

HG-102 UNITS

Either U.S. Customary, SI, or any local customary units may be used to demonstrate compliance with all requirements of this edition (e.g., materials, design, fabrication, examination, inspection, testing, certification, and overpressure protection).

In general, it is expected that a single system of units shall be used for all aspects of design except where unfeasible or impractical. When components are manufactured at different locations where local customary units are different than those used for the general design, the local units may be used for the design and documentation of that component. Similarly, for proprietary components or those uniquely associated with a system of units different than that used for the general design, the alternate units may be used for the design and documentation of that component.

For any single equation, all variables shall be expressed in a single system of units. When separate equations are provided for U.S. Customary and SI units, those equations must be executed using variables in the units associated with the specific equation. Data expressed in other units shall be converted to U.S. Customary or SI units for use in these equations. The result obtained from execution of these equations may be converted to other units.

Production, measurement and test equipment, drawings, welding procedure specifications, welding procedure and performance qualifications, and other fabrication documents may be in U.S. Customary, SI, or local customary units in accordance with the fabricator's practice. When values shown in calculations and analysis, fabrication documents, or measurement and test equipment are in different units, any conversions necessary for verification of Code compliance and to ensure that dimensional consistency is maintained shall be in accordance with the following:

(a) Conversion factors shall be accurate to at least four significant figures.

(b) The results of conversions of units shall be expressed to a minimum of three significant figures.

Conversion of units, using the precision specified above shall be performed to assure that dimensional consistency is maintained. Conversion factors between U.S. Customary and SI units may be found in the [Nonmandatory Appendix M](#), Guidance for the Use of U.S. Customary and SI Units in the ASME Boiler and Pressure Vessel Code. Whenever local customary units are used the Manufacturer shall provide the source of the conversion factors, which shall be subject to verification and acceptance by the Authorized Inspector.

Material that has been manufactured and certified to either the U.S. Customary or SI material specification (e.g., SA-516M) may be used regardless of the unit system used in design. Standard fittings (e.g., flanges, elbows, etc.) that have been certified to either U.S. Customary units or SI units may be used regardless of the unit system used in design.

All entries on a Manufacturer's Data Report and data for Code required nameplate marking shall be in units consistent with the fabrication drawings for the component using U.S. Customary, SI, or local customary units. It is acceptable to show alternate units parenthetically. Users of this Code are cautioned that the receiving Jurisdiction should be contacted to ensure the units are acceptable.

HG-103 TOLERANCES

Except as stated elsewhere in this section, Section IV does not fully address tolerances. When dimensions, sizes, or other parameters are not specified with tolerances, the values of these parameters are considered nominal, and allowable tolerances or local variances may be considered acceptable when based on engineering judgment and standard practices as determined by the designer.

ARTICLE 2

MATERIAL REQUIREMENTS

HG-200 GENERAL MATERIAL REQUIREMENTS

HG-200.1 Materials Subject to Pressure Stress.

Material subject to stress due to pressure shall conform to one of the specifications given in Section II and shall be limited to those that are permitted in [HF-200](#) for boilers of wrought materials and [HC-200](#) for cast iron boilers.

HG-200.2 Internal Parts Subject to Deterioration. Materials shall not be used for internal parts that are liable to fail due to deterioration when subjected to saturated steam temperatures at or below the maximum allowable working pressure.

HG-200.3 Materials Not Found in Section II. Material not covered by specifications in Section II shall not be used unless authorization to use the material is granted by the Boiler and Pressure Vessel Committee on the basis of data submitted to the Committee in accordance with Section II, Part D, Mandatory Appendix 5.

HG-200.4 Materials Use Not Limited by Specification Title. The title or scope paragraph of a material specification in Section II with respect to product form or service shall not limit the use of a material, provided the material is suitable for the application and its use is permitted by the rules of this Section.

HG-200.5 Materials Use Not Limited by Method of Production. Materials covered by specifications in Section II are not restricted as to the method of production

unless so stated in the Specification, and as long as the product complies with the requirements of the Specification.

HG-200.6 Materials With Thicknesses Exceeding Specification Limits. Materials having thicknesses outside of the limits given in the title or scope clause of a specification in Section II may be used in construction, provided they comply with the other requirements of the Specification and with all thickness requirements of this Code.

HG-200.7 Nonpressure Part Materials. Material for nonpressure parts, such as skirts, supports, baffles, lugs, clips, and extended heat-transfer surfaces, need not conform to the specifications for the material to which they are attached or to a material specification permitted in [HF-200](#) or [HC-200](#); but, if welded, they shall be of weldable quality. The allowable stress value shall not exceed 80% of the maximum allowable stress permitted for similar material in Section II, Part D, Table 6A or Table 6B. Satisfactory performance of a specimen in such service shall not make the material acceptable for use in pressure parts of a vessel.

HG-201 SPECIFIC MATERIAL REQUIREMENTS

Specific material requirements for assemblies constructed of wrought materials are given in [Part HF, Article 2](#) and for assemblies constructed of cast iron in [Part HC, Article 2](#).

ARTICLE 3 DESIGN

HG-300 DESIGN PRESSURE

(a) The design pressure is the pressure used in the formulas of this Article, in conjunction with the allowable stress values, design rules, and dimensions specified for determining the minimum required thicknesses for the parts of a boiler. The design pressure for a heating boiler shall be at least 30 psi (200 kPa).

(b) The term maximum allowable working pressure refers to gage pressure, or the pressure in excess of the atmospheric pressure in the boiler. The maximum allowable working pressure, as marked on the boiler per HG-530, must be less than or equal to the design pressure for any of its parts.

(c) No boiler shall be operated at a pressure higher than the maximum allowable working pressure except when the pressure relief valves are discharging, at which time the maximum allowable working pressure shall not be exceeded by more than the amount specified in HG-402A.1 and HG-402A.2.

HG-300.1 Vacuum Boilers. Rules for factory sealed boilers to be operated only under vacuum conditions are given in [Mandatory Appendix 5](#).

HG-301 CYLINDRICAL PARTS UNDER INTERNAL PRESSURE

HG-301.1 General. The required thickness and the design pressure of cylindrical shells, tubes, pipe, and headers shall be determined in accordance with the following formulas:

$$t = \frac{PR}{SE - 0.6P}$$

$$P = \frac{SEt}{R + 0.6t}$$

where

E = efficiency of longitudinal joint or of ligament between tube holes, whichever is the lesser. For welded joints, use the efficiency specified in [HW-702](#). For seamless shells, use $E = 1$. Welded pipe or tubing shall be treated in the same manner as seamless, but with allowable tensile

strength taken from the welded product values of the stress tables in Section II, Part D.

P = design pressure [but not less than 30 psi (200 kPa)]

R = inside radius of cylinder

S = maximum allowable stress value from Section II, Part D, Table 6A or Table 6B

t = required wall thickness

HG-301.2 Tubes.

(23)

(a) The wall thickness of tubes and pipes subject to internal pressure shall be determined in accordance with the formulas in [HG-301.1](#).

(b) The wall thickness of tubes and pipes subject to external pressure shall be determined by the procedures outlined in [HG-312.3](#).

(c) In no case shall a tube or a pipe used as a tube have a wall thickness less than 0.02 in. (0.5 mm).

(d) Tubes installed by expanding shall have an additional 0.04 in. (1 mm) of wall thickness added to the minimum required thickness as an allowance for expanding and structural stability.

(e) The design temperature of tubes shall be the mean metal temperature as determined by the boiler Manufacturer.

(f) For austenitic stainless steel materials, the water temperature shall not exceed 210°F (99°C).

(g) Welding or brazing shall be qualified in accordance with Section IX.

HG-305 FORMED HEADS, PRESSURE ON CONCAVE SIDE

HG-305.1 General. The required thickness at the thinnest point after forming¹ of ellipsoidal, torispherical, and hemispherical heads under pressure on the concave side (plus heads) shall be computed by the appropriate formulas in this paragraph.

(a) *Notation.* The symbols used in this paragraph are defined as follows:

D = inside diameter of the head skirt; or inside length of the major axis of an ellipsoidal head; or inside diameter of a cone head at the point under consideration, measured perpendicular to the longitudinal axis

E = lowest efficiency of any joint in the head. For welded joints, use the efficiency specified in [HW-702](#). For seamless heads, use $E = 1$, except for hemispherical heads furnished without a skirt, in which case use the efficiency of the head-to-shell joint.

L = inside spherical or crown radius

P = design pressure [but not less than 30 psi (200 kPa)]

S = maximum allowable stress value as given in Section II, Part D, Table 6A or Table 6B

t = required wall thickness after forming

HG-305.2 Ellipsoidal Heads. The required thickness and the design pressure of a dished head of semiellipsoidal form, in which half the minor axis (inside depth of the head minus the skirt) equals one-fourth of the inside diameter of the head skirt, shall be calculated by the following formulas:

$$t = \frac{PD}{2SE - 0.2P}$$

or

$$P = \frac{2SEt}{D + 0.2t}$$

HG-305.3 Torispherical Heads. The required thickness and the design pressure of a torispherical head shall be calculated by the following formulas (see [HG-305.6](#)):

$$t = \frac{0.885PL}{SE - 0.1P}$$

or

$$P = \frac{SEt}{0.885L + 0.1t}$$

HG-305.4 Hemispherical Heads. The required thickness and the design pressure of a hemispherical head in which P does not exceed $0.665SE$ shall be calculated by the following formulas:

$$t = \frac{PL}{2SE - 0.2P}$$

or

$$P = \frac{2SEt}{L + 0.2t}$$

HG-305.5 Formed Heads With Stays. A formed head of a lesser thickness than that required by the rules of this paragraph may be used provided it is stayed as a flat surface according to the rules of [HG-340](#) for stayed flat plates, no allowance being made in such staying for the holding power due to the curvature of the head unless all the following conditions are met:

(a) The head is at least two-thirds as thick as required by the rules of this paragraph for an unstayed head.

(b) The head is at least $\frac{7}{8}$ in. (22 mm) thick.

(c) The stays are through-stays attached to the head by outside and inside nuts or welding.

(d) The design pressure on the head is taken as that calculated for an unstayed formed head plus the pressure calculated for the stays by the equation for stayed surfaces in [HG-340](#) using a value of $C = 1.63$.

HG-305.6 Inside Crown Radius of Unstayed Heads. The inside crown radius to which an unstayed formed head is dished shall be not greater than the outside diameter of the skirt of the head. The inside knuckle radius of a torispherical head shall be not less than 6% of the outside diameter of the skirt of the head but in no case less than three times the head thickness.

HG-305.7 Heads Built up of Several Shapes. A head for a cylindrical shell may be built up of several head shapes, the thicknesses of which satisfy the requirements of the appropriate formulas above, provided that adjoining shapes are so formed that they have a common tangent transverse to the joint.

HG-305.8 Length of Skirts. The required length of skirt on heads concave and convex to pressure shall comply with [HW-715](#).

HG-305.9 Permissible Diameter of Flat Spots on Formed Heads. If a torispherical, ellipsoidal, or hemispherical head is formed with a flattened spot or surface, the diameter of the flat spot shall not exceed that permitted for flat heads as given by the equation in [HG-307](#), using $C = 0.20$.

HG-306 FORMED HEADS, PRESSURE ON CONVEX SIDE

HG-306.1 Unstayed dished heads with the pressure on the convex side shall have a design pressure equal to 60% of that for heads of the same dimensions having the pressure on the concave side (see [HG-305](#)).

HG-307 FLAT HEADS

HG-307.1 General. The minimum thickness of unstayed heads, cover plates, and blind flanges shall conform to the requirements given in this paragraph. These requirements apply to both circular and noncircular heads and covers. In addition, flat heads or covers made of cast iron shall be subjected to the proof test provisions of [HG-500](#). Some acceptable types of flat heads and covers are shown in [Figure HG-307](#).

The symbols used in this paragraph and [Figure HG-307](#) are defined as follows:

C = a factor depending upon the method of attachment of the head, shell, pipe, or header dimensions, and other items as listed in [HG-307.4](#) below, dimensionless. The factors for welded covers also

Figure HG-307
Some Acceptable Types of Unstayed Flat Heads and Covers

(23)

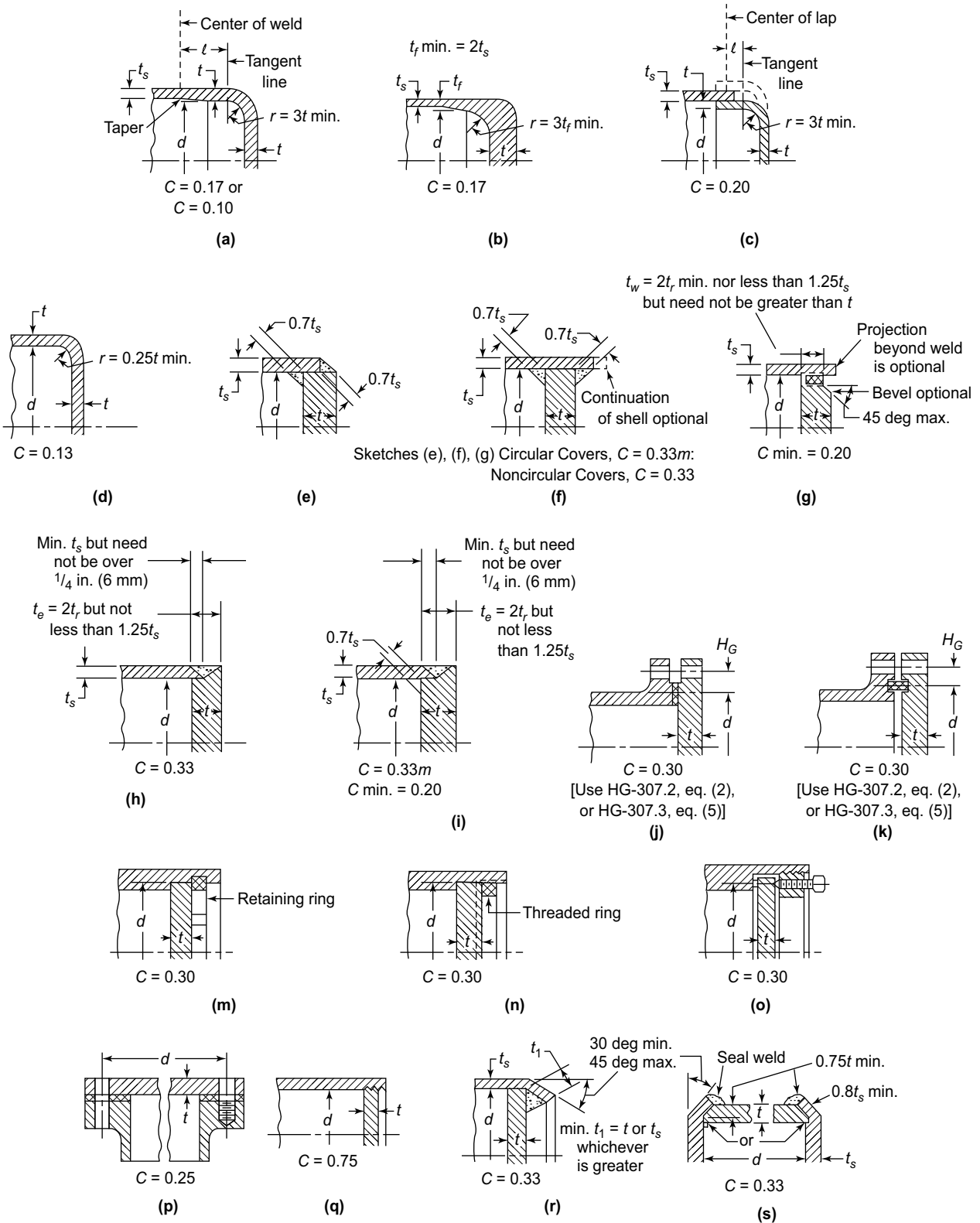

GENERAL NOTE: These illustrations are diagrammatic only; other designs that meet the requirements of HG-307 will be acceptable.

- include a factor of 0.667 that effectively increases the allowable stress for such construction to 1.5S.
- D = long span of noncircular heads or covers measured perpendicular to short span
- d = diameter, or short span, measured as indicated in [Figure HG-307](#)
- H_G = gasket moment arm, equal to the radial distance from the center line of the bolts to the line of the gasket reaction, as shown in [Figure HG-307](#), sketches (j) and (k)
- L = perimeter of noncircular bolted head measured along the centers of the bolt holes
- l = length of flange or flanged heads, measured from the tangent line of knuckle, as indicated in [Figure HG-307](#), sketches (a) and (c)
- m = the ratio t_r/t_s , dimensionless
- P = design pressure
- r = inside corner radius on the head formed by flanging or forging
- S = maximum allowable stress value using values given in Section II, Part D, Table 6A or Table 6B
- t = minimum required thickness of flat head or cover
- t_1 = throat dimension of the closure weld, as indicated in [Figure HG-307](#), sketch (r)
- t_e = minimum distance from beveled end of drum, pipe, or header, before welding, to outer face of head, as indicated in [Figure HG-307](#), sketch (i)
- t_f = actual thickness of the flange on a forged head, at the large end, as indicated in [Figure HG-307](#), sketch (b)
- t_h = actual thickness of flat head or cover
- t_r = required thickness of seamless shell, pipe, or header, for pressure
- t_s = actual thickness of shell, pipe, or header
- t_w = thickness through the weld joining the edge of a head to the inside of a drum, pipe, or header, as indicated in [Figure HG-307](#), sketch (g)
- W = total bolt load as further defined in [HG-307.2](#)
- Z = a factor for noncircular heads and covers that depends on the ratio of short span to long span, as given in [HG-307.3](#) below, dimensionless

HG-307.2 Thickness of Circular, Flat, Unstayed Heads, Covers, and Blind Flanges. The thickness of flat unstayed heads, covers, and blind flanges shall conform to one of the following requirements:²

(a) Circular blind flanges of ferrous materials conforming to ASME B16.5 shall be acceptable for the diameters and pressure-temperature ratings in Tables 2 through 8 of that Standard when of the types shown in [Figure HG-307](#), sketches (j) and (k).

(b) The minimum required thickness of flat unstayed circular heads, covers, and blind flanges shall be calculated by the following equation:

$$t = d\sqrt{CP/S} \quad (1)$$

except when the head, cover, or blind flange is attached by bolts causing an edge moment [[Figure HG-307](#), sketches (j) and (k)], in which case the thickness shall be calculated by

$$t = d\sqrt{CP/S + 1.9WH_G/Sd^3} \quad (2)$$

When using [eq. \(2\)](#), the thickness t shall be calculated for both operating conditions and gasket seating, and the greater of the two values shall be used. For operating conditions, the value of P shall be the design pressure, the value of S at design temperature shall be used, and W shall be the sum of the bolt loads required to resist the end pressure load and to maintain tightness of the gasket. For gasket seating, P equals zero, the value of S at atmospheric temperature shall be used, and W shall be the average of the required bolt load and the load available from the bolt area actually used.

HG-307.3 Thickness of Noncircular, Flat, Unstayed Heads, Covers, and Blind Flanges.

(a) Flat unstayed heads, covers, or blind flanges may be square, rectangular, elliptical, obround, segmental, or otherwise noncircular. Their required thickness shall be calculated by the following equation:

$$t = d\sqrt{ZCP/S} \quad (3)$$

where

$$Z = 3.4 - \frac{2.4d}{D} \quad (4)$$

with the limitation that Z need not be greater than 2.5.

(b) [Equation \(3\)](#) of (a) does not apply to noncircular heads, covers, or blind flanges attached by bolts causing a bolt edge moment [[Figure HG-307](#), sketches (j) and (k)]. For noncircular heads of this type, the required thickness shall be calculated by the following equation:

$$t = d\sqrt{ZCP/S + 6WH_G/SLd^2} \quad (5)$$

When using [eq. \(5\)](#), the thickness t shall be calculated in the same way as specified above for [HG-307.2\(b\)](#), [eq. \(2\)](#).

HG-307.4 Values of C for Use in Equations in HG-307.2 and HG-307.3. For the types of construction shown in [Figure HG-307](#), the values of C to be used in [HG-307.2\(b\)](#), [eqs. \(1\) and \(2\)](#); [HG-307.3\(a\)](#), [eq. \(3\)](#); and [HG-307.3\(b\)](#), [eq. \(5\)](#) are as follows:

(a) [Figure HG-307](#), sketch (a): $C = 0.17$ for flanged circular and noncircular heads forged integral with or butt welded to the shell, pipe, or header, with an inside corner radius not less than three times the required head thickness, with no special requirement with regard to length of flange, and where the welding meets all the

requirements for circumferential joints given in [Part HF, Subpart HW](#).

$C = 0.10$ for circular heads, when the flange length for heads of the above design is not less than

$$l = \left(1.1 - 0.8 \frac{t_s^2}{t_h^2} \right) \sqrt{dt_h} \quad (6)$$

When $C = 0.10$ is used, the taper shall be at least 1:3.

(b) [Figure HG-307](#), sketch (b): $C = 0.17$ for circular and noncircular heads forged integral with or butt welded to the shell, pipe, or header, where the corner radius on the inside is not less than three times the thickness of the flange and where the welding meets all the requirements for circumferential joints given in [Part HF, Subpart HW](#).

(c) [Figure HG-307](#), sketch (c): $C = 0.20$ for circular flanged plates screwed over the end of the shell, pipe, or header, with inside corner radius not less than $3t$, in which the design of the threaded joint against failure by shear, tension, or compression, resulting from the end force due to pressure, is based on a factor of safety of at least five, and the threaded parts are at least as strong as the threads for standard piping of the same diameter. Seal welding may be used, if desired.

(d) [Figure HG-307](#), sketch (d): $C = 0.13$ for integral flat circular heads when the dimension d does not exceed 24 in. (610 mm), the ratio of thickness of the head to the dimension d is not less than 0.05 nor greater than 0.25, the head thickness t_h is not less than the shell thickness t_s , the inside corner radius is not less than $0.25t$, and the construction is obtained by special techniques of upsetting and spinning the end of the shell, pipe, or header, such as employed in closing header ends.

(e) [Figure HG-307](#), sketches (e), (f), and (g): $C = 0.33m$ but not less than 0.20 for circular plates, welded to the inside of a drum, pipe, or header, and otherwise meeting the requirements for the respective types of fusion welded boiler drums. If a value of m less than 1 is used in calculating t , the shell thickness t_s shall be maintained along a distance inwardly from the inside face of the head equal to at least $2\sqrt{dt_s}$. The throat thickness of the fillet welds in sketches (e) and (f) shall be at least $0.7t_s$. The size of the weld t_w in sketch (g) shall be not less than two times the required thickness of a seamless shell nor less than 1.25 times the nominal shell thickness but need not be greater than the head thickness; the weld shall be deposited in a welding groove with the root of the weld at the inner face of the head as shown in the figure.

$C = 0.33$ for noncircular plates, welded to the inside of a drum, pipe, or header, and otherwise meeting the requirements for the respective types of fusion welded boiler drums. The throat thickness of the fillet welds in sketches (e) and (f) shall be at least $0.7t_s$. The size of the weld t_w in sketch (g) shall be not less than two times the required thickness of a seamless shell nor less than 1.25 times the

nominal shell thickness but need not be greater than the head thickness; the weld shall be deposited in a welding groove with the root of the weld at the inner face of the head as shown in the figure.

(f) [Figure HG-307](#), sketch (h): $C = 0.33$ for circular plates welded to the end of the shell when t_s is at least $1.25t_r$ and the beveled end of the shell is located at a distance no less than $2t_r$ nor less than $1.25t_s$ from the outer face of the head. The width at the bottom of the welding groove shall be at least equal to the shell thickness but need not be over $\frac{1}{4}$ in. (6 mm).

(g) [Figure HG-307](#), sketch (i): $C = 0.33m$ but not less than 0.20 for circular plates welded to the end of the drum, pipe, or header, when an inside weld with minimum throat thickness of $0.7t_s$ is used, and when the beveled end of the drum, pipe, or header is located at a distance not less than $2t_r$ nor less than $1.25t_s$ from the outer face of the head. The width at the bottom of the welding groove shall be at least equal to t_s , but need not be over $\frac{1}{4}$ in. (6 mm).

(h) [Figure HG-307](#), sketches (j) and (k): $C = 0.3$ for circular and noncircular heads and covers bolted to the shell, flange, or side plate, as indicated in the figures. Note that [HG-307.2\(b\)](#), eq. (2) or [HG-307.3\(b\)](#), eq. (5) shall be used because of the extra moment applied to the cover by the bolting. When the cover plate is grooved for a peripheral gasket, as shown in sketch (k), the net cover plate thickness under the groove or between the groove and the outer edge of the cover plate shall be not less than

$$d\sqrt{1.9WH_G/Sd^3}$$

for circular heads and covers, nor less than

$$d\sqrt{6WH_G/SLd^2}$$

for noncircular heads and covers.

(i) [Figure HG-307](#), sketches (m), (n), and (o): $C = 0.3$ for a circular plate inserted into the end of a shell, pipe, or header, and held in place by a positive mechanical locking arrangement, and when all possible means of failure either by shear, tension, compression, or radial deformation, including flaring, resulting from pressure and differential thermal expansion, are resisted with a factor of safety of at least five. Seal welding may be used, if desired.

(j) [Figure HG-307](#), sketch (p): $C = 0.25$ for circular and noncircular covers bolted with a full-face gasket to shells, flanges, or side plates.

(k) [Figure HG-307](#), sketch (q): $C = 0.75$ for circular plates screwed into the end of a shell, pipe, or header, having an inside diameter d not exceeding 12 in. (300 mm); or for heads having an integral flange screwed over the end of a shell, pipe, or header, having an inside diameter d not exceeding 12 in. (300 mm); and when the design of the threaded joint against failure by shear, tension, compression, or radial deformation, including flaring, resulting from pressure

and differential thermal expansion, is based on a factor of at least five. If a tapered pipe thread is used, the requirements of [Table HG-370](#) shall also be met. Seal welding may be used, if desired.

(l) [Figure HG-307](#), sketch (r): $C = 0.33$ for circular plates having a dimension d not exceeding 18 in. (450 mm) inserted into the shell, pipe, or header, and welded as shown, and otherwise meeting the requirements for fusion welded boiler drums. The end of the shell, pipe, or header shall be crimped over at least 30 deg, but not more than 45 deg. The crimping may be done cold only when this operation will not injure the metal. The throat of the weld shall be not less than the thickness of the flat head or the shell, pipe, or header, whichever is greater.

(m) [Figure HG-307](#), sketch (s): $C = 0.33$ for circular beveled plates having a diameter not exceeding 18 in. (450 mm), inserted into a shell, pipe, or header, the end of which is crimped over at least 30 deg, but not more than 45 deg, and when the undercutting for seating leaves at least 80% of the shell thickness. The beveling shall be not less than 75% of the head thickness. The crimping shall be done when the entire circumference of the cylinder is uniformly heated to the proper forging temperature for the material used. For this construction, the ratio t_s/d shall be not less than the ratio P/S nor less than 0.05. The design pressure for this construction shall not exceed $P = S/5d$.

[Figure HG-307](#) is diagrammatic only. Other designs that meet the requirements of [HG-307](#) will be acceptable.

(23) **HG-307.5 Electric Immersion Heating Element Support Plates.** Electric immersion heating element support plates shall be supplied using one of the following options:

(a) by a Section IV “H” Certificate Holder and shall be designed to the rules of [HG-307](#) and [HG-325](#).

(b) by a Section IV “H” Certificate Holder or by a Section VIII, Division 1 “U” Certificate Holder. The design shall be to the rules of Section VIII, Division 1, Mandatory Appendix 41. In the Remarks section of the Section IV Manufacturer’s Data Report, the Manufacturer shall include the statement, “Electric immersion heater element support plate(s) designed in accordance with Section VIII, Division 1, Mandatory Appendix 41.” When the part is manufactured by a “U” Certificate Holder, the U-2 Partial Data Report will be referenced on the Manufacturer’s Data Report, [Form H-2](#).

(c) as a manufacturer’s standard pressure part per [HF-203](#).

HG-309 SPHERICALLY DISHED COVERS (BOLTED HEADS)

The symbols used in the formulas of this paragraph are defined as follows:

A = outside diameter of flange

B = inside diameter of flange

C = bolt circle diameter

L = inside spherical or crown radius

M_o = the total moment determined as in Section VIII, Division 1, Mandatory Appendix 2, 2-6, except that for heads of the type shown in [Figure HG-309](#), sketch (d), a moment $H_r h_r$ (which may add or subtract) shall be included in addition to the moment $H_D h_D$ where

H_D = axial component of the membrane load in the spherical segment acting at the inside of the flange ring
 $= 0.785B^2P$

h_D = radial distance from the bolt circle to the inside of the flange ring

H_r = radial component of the membrane load in the spherical segment acting at the intersection of the inside of the flange ring with the center line of the dished cover thickness

$= H_D \cot \beta_1$

h_r = lever arm of force H_r about centroid of flange ring

NOTE: Since $H_r h_r$ in some cases will subtract from the total moment, the moment in the flange ring when the internal pressure is zero may be the determining loading for the flange design.

P = design pressure

r = inside knuckle radius

S = maximum allowable stress value as given in Section II, Part D, Table 6A or Table 6B

T = flange thickness

t = minimum required thickness of head plate after forming

HG-309.1 Heads Concave to Pressure. Circular spherically dished heads with bolting flanges, concave to the pressure and conforming to the several types illustrated in [Figure HG-309](#) shall be designed in accordance with the following formulas:

(a) *Heads of the Type Shown in [Figure HG-309](#), Sketch (a)*

(1) The thickness of the head t shall be determined by the appropriate equation in [HG-305](#).

(2) The head radius L or the knuckle radius r shall not exceed the limitations given in [HG-305](#).

(3) The flange shall comply at least with the requirements of Section VIII, Division 1, Mandatory Appendix 2, Figure 2-4 and shall be designed in accordance with the provisions of Section VIII, Division 1, Mandatory Appendix 2, 2-1 through 2-7. (Within the range of ASME B16.5, the flange facings and drillings should conform to those

Figure HG-309
Spherically Dished Steel Plate Covers With Bolting Flanges

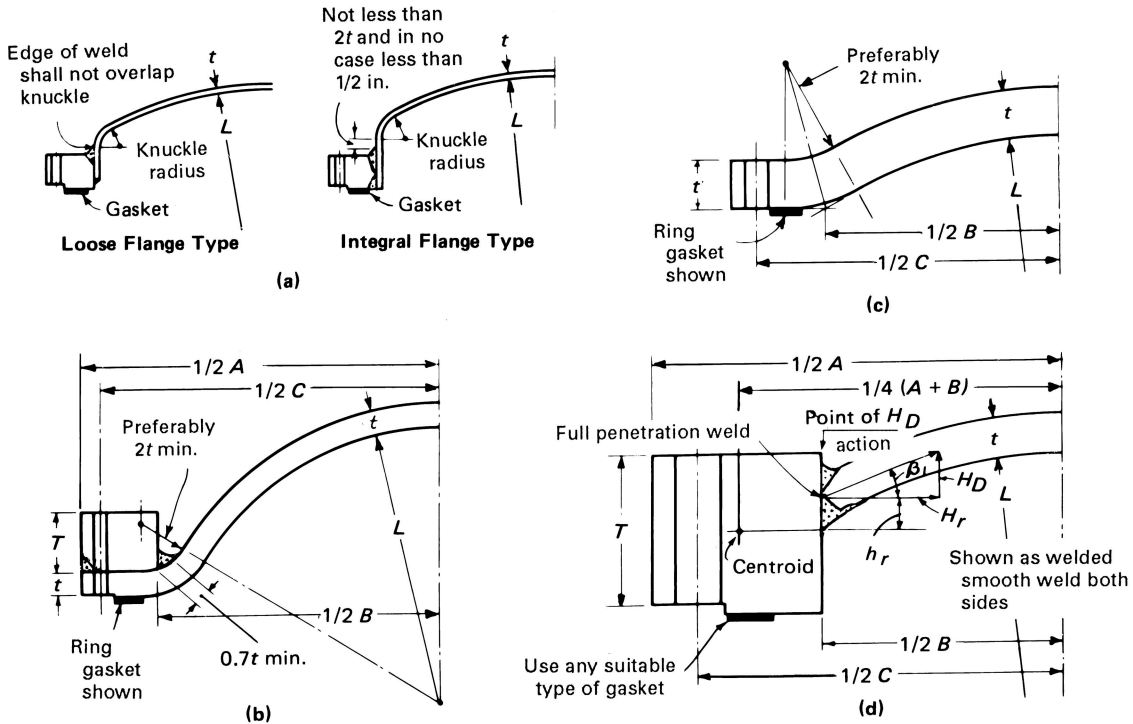

standards and the thickness specified therein shall be considered as a minimum requirement.)

(b) Heads of the Type Shown in Figure HG-309, Sketch (b). (No joint efficiency factor is required.)

(1) Head thickness

$$t = \frac{SPL}{6S}$$

(2) Flange thickness T

(-a) For ring gasket,

$$T = \sqrt{\frac{M_o}{SB} \left[\frac{A + B}{A - B} \right]}$$

(-b) For full-face gasket,

$$T = 0.6 \sqrt{\frac{P}{S} \left[\frac{B(A + B)(C - B)}{A - B} \right]}$$

NOTE: The radial components of the membrane load in the spherical segment are assumed to be resisted by its flange. Within the range of ASME B16.5, the flange facings and drillings should conform to those standards, and the thickness specified herein shall be considered as a minimum requirement.

(c) Heads of the Type Shown in Figure HG-309, Sketch (c). (No joint efficiency factor is required.)

(1) Head thickness

$$t = \frac{SPL}{6S}$$

(2) Flange thickness for ring gaskets shall be calculated as follows:

(-a) For heads with round bolting holes,

$$T = Q + \sqrt{\frac{1.875M_o(C + B)}{SB(7C - 5B)}} \quad (1)$$

where

$$Q = \frac{PL}{4S} \left[\frac{C + B}{7C - 5B} \right] \quad (2)$$

(-b) For heads with bolting holes slotted through the edge of the head,

$$T = Q + \sqrt{\frac{1.875M_o(C + B)}{SB(3C - 5B)}} \quad (3)$$

where

$$Q = \frac{PL}{4S} \left[\frac{C + B}{3C - 5B} \right] \quad (4)$$

(3) Flange thickness for full-face gaskets shall be calculated by the following equation:

$$T = Q + \sqrt{Q^2 + \frac{3BQ(C - B)}{L}} \quad (5)$$

The value of Q in eq. (5) is calculated by (2)(-a), eq. (2) for round bolting holes or by (2)(-b), eq. (4) for bolting holes slotted through the edge of the head.

(4) The required flange thickness shall be T as calculated in (2) or (3) above, but in no case less than the value of t calculated in (1) above.

(d) Heads of the Type Shown in Figure HG-309, Sketch (d). (No joint efficiency factor is required.)

(1) Head thickness

$$t = \frac{SPL}{6S}$$

(2) Flange thickness

$$T = F + \sqrt{F^2 + J}$$

where

$$F = \frac{PB\sqrt{4L^2 - B^2}}{8S(A - B)}$$

and

$$J = \left(\frac{M_o}{SB}\right)\left(\frac{A + B}{A - B}\right)$$

HG-312 CYLINDRICAL PARTS UNDER EXTERNAL PRESSURE

HG-312.1 Plain Type Furnaces. Plain furnaces that are complete cylinders shall conform to the following:

(a) The thickness of the furnace wall shall be not less than $\frac{3}{16}$ in. (5 mm) except alloy steel plates listed in Section II, Part D, Table 6A shall be not less than $\frac{3}{32}$ in. (2.5 mm).

(b) The design temperature of the furnace shall be not less than the mean expected wall temperature.

(c) Furnaces shall be rolled to a circle, with a maximum deviation from the true circle of not more than $\frac{1}{4}$ in. (6 mm).

(d) The thickness of the furnace wall shall be determined by the use of the rules of HG-312.3. External pressure charts for use in determining minimum requirements are given in Section II, Part D, Subpart 3. Figure numbers in this Article are contained in that Subpart. The symbols defined as follows are used in the formulas of this paragraph:

A = factor determined from Section II, Part D, Subpart 3, Figure G and used to enter the applicable material chart in Section II, Part D, Subpart 3

B = factor determined from the applicable material chart in Section II, Part D, Subpart 3 for maximum design, metal temperature [see (b)]

D_o = outside diameter of furnace

L = design length of plain furnace taken as the distance from center to center of weld attachment, in.; design length of ring reinforced furnace section, taken as the greatest center-to-center distance between any two adjacent stiffening rings; or the distance from the center of the first stiffening ring to the center of the furnace weld attachment, in. In case a flared-end assembly is used, the distance shall be measured to the point of tangency between the flare and the furnace and the adjacent stiffening ring.

P = design pressure

t = minimum required wall thickness of furnaces

HG-312.3 Procedure for Determining Wall Thickness of Plain Furnaces and Tubes.

The required wall thickness of the furnace and tubes shall be not less than determined by the following procedure:

Step 1. Assume a value for t . Determine the ratio L/D_o and D_o/t .

Step 2. Enter Section II, Part D, Subpart 3, Figure G at the value of L/D_o determined in Step 1. For values of L/D_o greater than 50, enter the chart at a value of $L/D_o = 50$. For values of L/D_o less than 0.05, enter the chart at a value of $L/D_o = 0.05$.

Step 3. Move horizontally to the line for the value of D_o/t determined in Step 1. Interpolation may be made for intermediate values of D_o/t . From this point of intersection, move vertically downward to determine the value of factor A .

Step 4. Using the value of A calculated in Step 3, enter the applicable material chart in Section II, Part D, Subpart 3 for the material under consideration. Move vertically to an intersection with the material/temperature line for the design temperature.

Step 5. From the intersection obtained in Step 4, move horizontally to the right and read the value of factor B .

Step 6. Using this value of B , calculate the value of the maximum allowable external working pressure P_a using the following equation:

$$P_a = \frac{B}{D_o/t}$$

Step 7. Compare P_a with P . If P_a is less than P , a greater value of t must be selected or a smaller value of L or some combination of both to increase P_a so that it is equal to or greater than P . (An example is included in Nonmandatory Appendix C.)

Figure HG-312.4
Acceptable Type of Ring-Reinforced Furnace

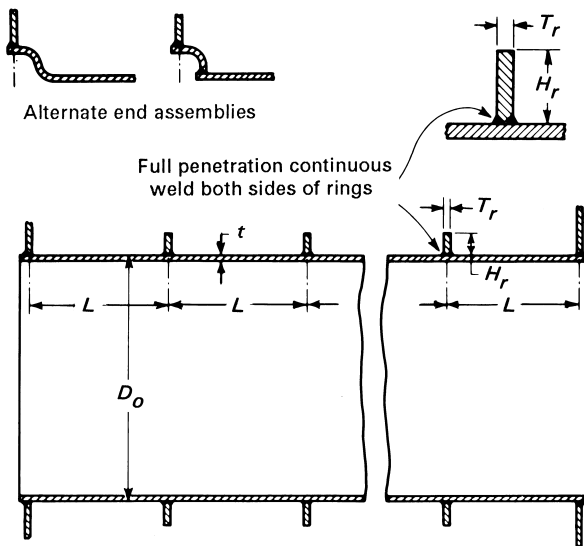

HG-312.4 Ring Reinforced Type Furnace. Ring reinforced furnaces as shown in Figure HG-312.4 may be constructed with completely circular stiffening rings provided

(a) the stiffening ring is rectangular in cross section and is fabricated from one piece of plate, or from plate sections or bars provided full-penetration welds are used in assembling.

(b) the stiffening ring after fabrication has a thickness of not less than $\frac{5}{16}$ in. (8 mm) and not more than $\frac{13}{16}$ in. (21 mm) and in no case thicker than $1\frac{1}{4}$ times the furnace wall.

(c) the ratio of height of the stiffening ring to its thickness (H_r/T_r) is not over eight nor less than three.

(d) the stiffening ring is attached to the furnace by a full penetration weld as shown in Figure HG-312.4.

(e) the thickness of the furnace wall is a minimum of $\frac{1}{4}$ in. (6 mm).

(f) the design temperature of the furnace shall be taken as 500°F (260°C).

(g) the boiler design permits replacement of the furnace. A flared or welded OG-ring may be accepted as meeting this requirement. (See Figure HG-312.4.)

(h) the thickness of the furnace wall or tube wall and the design of stiffening rings are determined by the procedure contained in HG-312.3, Steps (1) through (7). L is as defined in HG-312.1. The symbols defined in HG-312.1 are used in the design formula. HG-312.3, Steps (1) through (7) shall apply.

(i) the required moment of inertia of a circumferential stiffening ring shall not be less than determined by the following formula:

$$I_s = \frac{D_o^2 L \left(t + \frac{A_s}{L} \right) A}{14}$$

where

A_s = cross-sectional area of the stiffening ring, in.² (mm²)

I_s = required moment of inertia of the stiffening ring about its neutral axis parallel to the axis of the furnace, in.⁴ (mm⁴)

P , D_o , and t are as defined in HG-312.1.

HG-312.5 Procedure for Determining Moment of Inertia of Stiffening Rings. The moment of inertia for a stiffening ring shall be determined by the following procedure.

Step 1. Assuming that the furnace has been designed and D_o , L , and t are known, select a rectangular member to be used for a stiffening ring and determine its area A_s and its moment of inertia I . Then calculate B by the following formula:

$$B = \frac{PD_o}{t + \frac{A_s}{L}}$$

where B is as defined in HG-312.1. P , D_o , t , A_s , and L are defined above.

Step 2. Enter the right-hand side of the applicable material chart in Section II, Part D, Subpart 3 for the material under consideration at the value of B determined in Step 1.

Step 3. Follow horizontally to the material line.

Step 4. Move down vertically to the bottom of the chart and read the value of A .

Step 5. Compute the value of the required moment of inertia I_s from the formula given above.

Step 6. If the required I_s is greater than the moment of inertia I for the section selected in Step 1, a new section with a larger moment of inertia must be selected and a new I_s determined. If the required I_s is smaller than I for the section selected by Step 1, that section should be satisfactory. (An example is included in Nonmandatory Appendix C.)

HG-312.6 Corrugated Furnaces. The design pressure of corrugated furnaces, such as the Leeds suspension bulb, Morison, Fox, Purves, or Brown, having plain portions at the ends not exceeding 9 in. (225 mm) in length shall be computed as follows:

$$P = Ct/D$$

where

- C = 17,300 psi (119 000 kPa), a constant for Leeds furnaces, when corrugations are not more than 8 in. (200 mm) from center to center and not less than $2\frac{1}{4}$ in. (57 mm) deep
- = 15,600 psi (108 000 kPa), a constant for Morison furnaces, when corrugations are not more than 8 in. (200 mm) from center to center and the radius of the outer corrugation is not more than one-half of the suspension curve
- = 14,000 psi (96 500 kPa), a constant for Fox furnaces, when corrugations are not more than 8 in. (200 mm) from center to center and not less than $1\frac{1}{2}$ in. (38 mm) deep
- = 14,000 psi (96 500 kPa) a constant for Purves furnaces, when rib projections are not more than 9 in. (225 mm) from center to center and not less than $1\frac{3}{8}$ in. (35 mm) deep
- = 14,000 psi (96 500 kPa) a constant for Brown furnaces, when corrugations are not more than 9 in. (225 mm) from center to center and not less than $1\frac{5}{8}$ in. (41 mm) deep
- D = mean diameter, in. (mm)
- P = design pressure, psi (kPa)
- t = thickness, in. (mm), not less than $\frac{5}{16}$ in. (8 mm) for Leeds, Morison, Fox, and Brown, and not less than $\frac{7}{16}$ in. (11 mm) for Purves and other furnaces corrugated by sections not over 18 in. (450 mm) long

(a) In calculating the mean diameter of the Morison furnace, the least inside diameter plus 2 in. (50 mm) may be taken as the mean diameter.

(b) The longitudinal and circumferential joints shall be fusion welded of the double-welded butt type.

(c) The thickness of a corrugated or ribbed furnace shall be ascertained by actual measurement by the furnace manufacturer, by gaging the thickness of the corrugated portions. If a hole is drilled through the sheet to determine the thickness, the hole shall be not more than $\frac{3}{8}$ in. (10 mm). When the furnace is installed, this hole shall be located in the bottom of the furnace and closed by a threaded plug. For the Brown and Purves furnaces, the hole shall be in the center of the second flat from the boiler front; for the Morison, Fox, and other similar types, in the center of the top corrugation, at least as far in as the fourth corrugation from the front end of the furnace.

HG-312.7 Combination Type Furnaces.

Combination type furnaces for external pressure may be constructed by combining a plain circular section and a corrugated section provided

(a) each type of furnace is designed to be self-supporting, requiring no support from the other furnace at their point of connection.

(b) HG-312.1 and HG-312.3 shall be used for calculating the design pressure of the plain section; in applying the length in the text, or L in the formulas, the length used shall always be twice the actual length of the plain section; the actual length of plain section is the distance measured from the center line of the head attachment weld to the center line of the full penetration weld joining the two sections.

(c) the design pressure of the corrugated section shall be determined from HG-312.6.

(d) the full penetration weld joining a plain self-supporting section to a corrugated self-supporting section shall be located as shown in Figure HG-312.7.

HG-312.8 Semicircular Furnaces or Crown Sheets Subjected to External Pressure. Unstayed furnaces or crown sheets where the top portion is semicircular and the unstayed portion does not exceed 120 deg in arc shall conform to the following.

(a) The thickness of the semicircular furnace or crown sheet shall be not less than $\frac{5}{16}$ in. (8 mm).

(b) The design temperature of the semicircular furnace or crown sheet shall be taken as 500°F (260°C).

(c) Semicircular portions of the furnace or crown sheet shall be rolled to practically a true circle, with a maximum deviation from the true circle of not more than $\frac{1}{4}$ in. (6 mm).

(d) The allowable working pressure of the semicircular furnace or crown sheet shall be not more than 70% of P_d as computed from the procedure outlined in HG-312.1 and HG-312.3 and using the applicable chart.

(e) *Bar Reinforcement*

(1) Bar reinforcement, when required to reduce the effective furnace length L , shall be computed using the formulas in HG-312.5 and HG-312.4.

(2) Bar reinforcement shall be fabricated and installed as shown in Figure HG-312.8.

(3) Bar reinforcement, after fabrication, shall have a thickness of not less than $\frac{5}{16}$ in. (8 mm) and not more than $1\frac{3}{16}$ in. (21 mm) and in no case thicker than $1\frac{1}{4}$ times the wall section of the semicircular portion.

Figure HG-312.7
Connection Between Plain and Corrugated Furnace

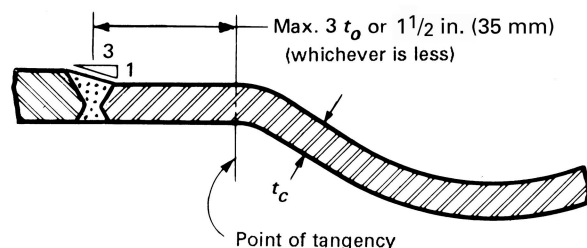
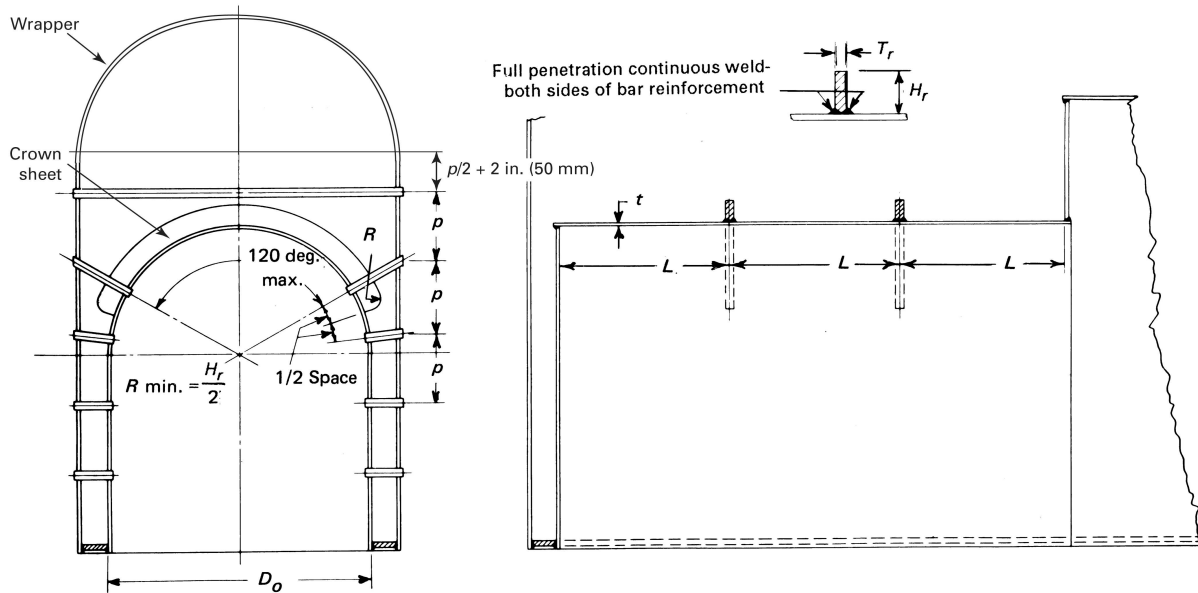

Figure HG-312.8
Acceptable Type of Semicircular Furnace Reinforcement



(4) The ratio of height of the bar reinforcement to its thickness H_r/T_r shall be not more than eight nor less than three.

(f) For unstayed furnaces or crown sheets, where the top portion is semicircular and the unstayed portion exceeds 120 deg in arc, that portion exceeding the 120 deg arc shall be stayed as a flat plate in accordance with HG-340.

(g) For unstayed firebox boiler wrappers or shells, where the top portion is semicircular, the required thickness shall be in accordance with HG-301. The maximum distance between the tangent of the semicircular top and the first stay in the flat side shall be a maximum of $p/2 + 2$ in. (50 mm) as shown in Figure HG-312.8, where p is the maximum allowable pitch calculated in accordance with HG-340.1(a).

HG-320 OPENINGS IN BOILERS, GENERAL REQUIREMENTS^{3, 4}

HG-320.1 Shape of Openings.⁵ Openings in cylindrical, spherical, or conical portions of boilers or in formed heads shall preferably be circular, elliptical, or obround⁶ except as otherwise provided in HG-320.2. When the long dimension of an elliptical or obround opening exceeds twice the short dimension, the reinforcement across the short dimension shall be increased as necessary to provide against excessive distortion due to twisting moment.

HG-320.2 Size of Openings. While openings in cylindrical and spherical shells are not limited as to size provided they are adequately reinforced, the rules given herein for reinforcement are intended to apply to openings not exceeding the following dimensions:

(a) for boilers 60 in. (1 500 mm) in diameter and less: one-half the boiler diameter but not over 20 in. (500 mm).

(b) for boilers over 60 in. (1 500 mm) in diameter: one-third the boiler diameter, but not over 40 in. (1 000 mm).

(c) larger openings should be given special attention and may be provided with reinforcement in any suitable manner that complies with the intent of the Code rules. It is recommended that the reinforcement provided be distributed close to the opening. (A provision of about two-thirds of the required reinforcement within a distance of one-fourth of the nozzle diameter on each side of the finished opening is suggested.) Special consideration should be given to the fabrication details used and the inspection employed on critical openings; reinforcement often may be advantageously obtained by use of a thicker shell plate for a boiler course or inserted locally around the openings; welds may be ground to concave contour and the inside corners of the opening rounded to a generous radius to reduce stress concentrations. Appropriate proof testing may be advisable in extreme cases of large openings approaching full boiler diameter, openings of unusual shape, etc.

HG-320.3 Strength and Design of Finished Openings.

(a) All references to dimensions in this and succeeding paragraphs apply to the finished construction after adjustment has been made for any material added as corrosion or other allowance. For design purposes, no metal added as corrosion or other allowance may be considered as reinforcement. Reinforcement shall be provided to satisfy the requirements of HG-321 for all openings except as otherwise provided in (b), (c), and (d) below.

(b) Openings in a definite pattern, such as tube holes, may be designed in accordance with the rules for ligaments in HG-350 provided the diameter of the largest hole in the group does not exceed that permitted by the equation in (d).

(c) No calculations need be made to determine the availability of reinforcement for single openings in boilers not subject to rapid fluctuations in pressure or temperature and in which the outside diameter of the opening does not exceed one-fourth of the inside diameter of the boiler, provided the diameter of the finished opening as defined in HG-321.2 does not exceed the following sizes:

(1) NPS 2 (DN 50) for welded connections in boiler walls over $\frac{3}{8}$ in. (10 mm) thick and for all threaded, studded, or expanded connections

(2) NPS 3 (DN 80) for welded connections in boiler walls $\frac{3}{8}$ in. (10 mm) thick and under

(d) No calculations need be made to demonstrate compliance with HG-321 for single openings not covered in (c) when either the diameter of the opening in the shell or header does not exceed that permitted in the following equation or the calculated K value is less than 50%.

(U.S. Customary Units)

$$d = 2.75 [Dt(1 - K)]^{1/3}$$

(SI Units)

$$d = 8.08 [Dt(1 - K)]^{1/3}$$

where

D = outer diameter of the shell, in. (mm)

d = maximum allowable diameter of opening, in. (mm)

$K = PD/2St$

P = design pressure

S = maximum allowable stress value taken from Section II, Part D, Table 6A or Table 6B

t = nominal thickness of the shell, in. (mm)

Three significant figures shall be employed for the variables in the equation and in the resulting value of d . Additional significant figures are permitted but not

required. K as used in the equation is limited to a maximum of 0.990.

HG-321 REINFORCEMENT REQUIRED FOR OPENINGS IN SHELLS AND FORMED HEADS

HG-321.1 General. The rules in this subparagraph apply to all openings other than openings in a definite pattern covered by HG-320.3(b), openings covered by HG-320.3(c) and HG-320.3(d), flanged-in openings in formed heads covered by HG-323, and openings in flat heads covered by HG-325.

Reinforcement shall be provided in such amount and distribution that the requirements for area of reinforcement are satisfied for all planes through the center of the opening and normal to the boiler surface. For a circular opening in a cylindrical shell, the plane containing the axis of the shell is the plane of greatest loading due to pressure.

HG-321.2 Design for Internal Pressure. The total cross-sectional area of reinforcement A required in any given plane for a boiler under internal pressure shall be not less than

$$A = dt_r F + 2t_n t_r F(1 - f_{r1})$$

where

d = the diameter in the given plane of the finished opening (as depicted in Figure HG-326.1)

F = a correction factor that compensates for the variation in pressure stresses on different planes with respect to the axis of a vessel. A value of 1.00 shall be used for all configurations except that Figure HG-321 may be used for integrally reinforced openings in cylindrical shells.

t_r = the required thickness of a seamless shell or head computed by the rules of the Code for the designated pressure except that

(a) when the opening and its reinforcement are in a torispherical head and are entirely within the spherical portion, t_r is the thickness required for a seamless hemispherical head of the same radius as that of the spherical portion

(b) when the opening is in a cone, t_r is the thickness required for a seamless cone of diameter D measured where the nozzle axis pierces the inside wall of the cone

(c) when the opening and its reinforcement are in an ellipsoidal head and are located entirely within a circle the center of which coincides with the center of the head and the diameter of which is equal to 80% of the shell diameter, t_r is the thickness required for a sphere of radius $K_1 D$ where D is the shell diameter and K_1 is given by Table HG-321

Figure HG-321
Chart for Determining Values of F

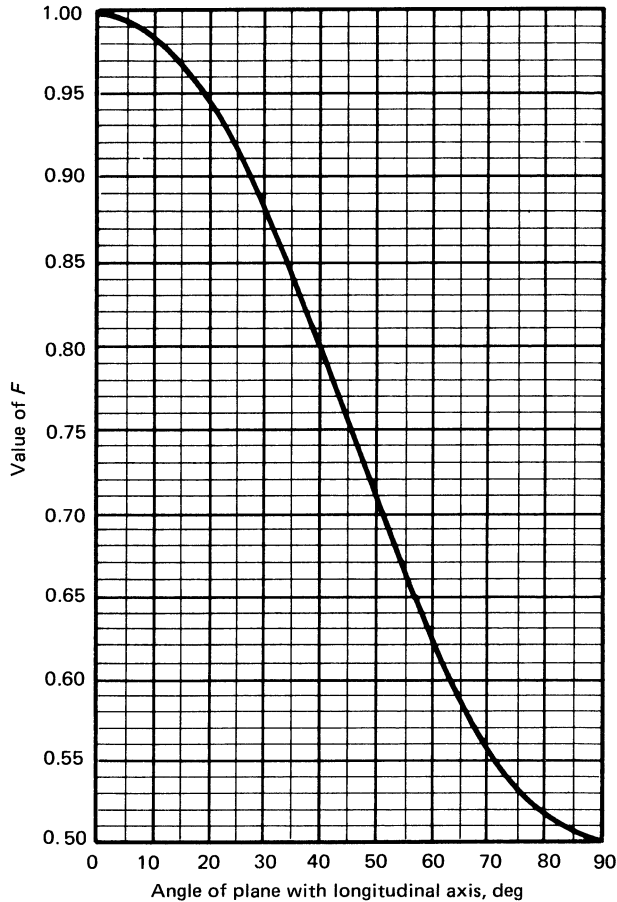

Table HG-321

Values of Spherical Radius Factor K_1

$D/2d$	K_1	$D/2d$	K_1
3.0	1.36	1.8	0.81
2.8	1.27	1.6	0.73
2.6	1.18	1.4	0.65
2.4	1.08	1.2	0.57
2.2	0.99	1.0	0.50
2.0	0.90

GENERAL NOTES:

- (a) Equivalent Spherical Radius = K_1D ; $D/2d$ = axis ratio. Interpolation Permitted for Intermediate Values.
- (b) D = inside length of major axis, in. (mm).
- (c) d = inside depth of ellipsoidal head measured from the tangent line, in. (mm).

HG-323 FLANGED-IN OPENINGS IN FORMED HEADS

HG-323.1 Reinforcement Requirements. Flanged-in openings in torispherical, ellipsoidal, and hemispherical heads shall be provided with reinforcement in accordance with [HG-321](#), except for heads that meet the requirements in [HG-323.2](#), [HG-323.3](#), and [HG-323.4](#).

HG-323.2 Restrictions on Location. The flanged-in opening and its reinforcement shall be entirely within the spherical portion of torispherical heads, and within a circle the center of which coincides with the center of the head and the diameter of which equals 80% of the shell diameter for ellipsoidal and hemispherical heads. The center line of the opening shall not be closer to the above boundary circle than the diameter of the opening.

HG-323.3 Minimum Thickness Requirements of Flanged-In Openings.

(a) For flanged-in openings that do not exceed 6 in. (150 mm) in any dimension and for flanged-in openings of any dimension that are stayed by an attached flue, the thickness of the head shall not be less than that required by [HG-305](#) for a blank head, nor less than that required by [HG-305](#) for torispherical heads.

(b) For unstayed flanged-in openings that exceed 6 in. (150 mm) in any inside dimension, the head thickness shall be increased 15% but not less than $\frac{1}{8}$ in. (3 mm) greater than that required by (a) above.

HG-323.4 Minimum Flange Depth. The minimum depth of flange of a flanged-in opening, when not stayed by an attached flue, shall equal $3t$ or $(t + 3)$ in., whichever is less, where t is the required head thickness. The depth of flange shall be determined by placing a straightedge across the outside of the opening along the major axis and measuring from the straightedge to the edge of the flanged opening.

HG-323.5 Minimum Gasket Bearing Surface. The minimum width of bearing surface for a gasket on a flanged-in manhole opening shall be $\frac{1}{16}$ in. (17 mm).

HG-325 REINFORCEMENT REQUIRED FOR OPENINGS IN FLAT HEADS

HG-325.1 General. The rules in this paragraph apply to all openings other than small openings covered by [HG-320.3\(c\)](#).

HG-325.2 Specific Requirements. Flat heads that have an opening with a diameter that does not exceed one-half of the head diameter or shortest span, as defined in [HG-307](#), shall have a total cross-sectional

area of reinforcement not less than that given by the formula:

$$A = 0.5dt$$

where

- d = diameter of the finished opening
 t = minimum required thickness of plate

As an alternative, the thickness of flat heads may be increased to provide the necessary opening reinforcement as follows:

(a) in HG-307.2(b), eq. (1), or HG-307.3(a), eq. (3) by using $2C$ or 0.75 in place of C , whichever is less.

(b) in HG-307.2(b), eq. (2), or HG-307.3(b), eq. (5) by doubling the quantity under the square root sign. Except for the types of construction shown in Figure HG-307, sketches (j) and (k), the value of $2C$ to be used in the equations need not exceed 0.75 .

HG-326 LIMITS OF METAL AVAILABLE FOR REINFORCEMENT

HG-326.1 Designation of Limits of Reinforcement. The boundaries of the cross-sectional area in any plane normal to the boiler shell and passing through the center of the opening within which area metal must be located in order to have value as reinforcement are designated as the limits of reinforcement for that plane.

HG-326.2 Limits of Reinforcement Parallel to Boiler Shell. The limits of reinforcement, measured parallel to the boiler shell, shall be at a distance, on each side of the axis of the opening, equal to the greater of the following:

- (a) the diameter of the finished opening
 (b) the radius of the finished opening plus the thickness of the boiler shell, plus the thickness of the nozzle wall

HG-326.3 Limits of Reinforcement Normal to Boiler Shell. The limits of reinforcement, measured normal to the boiler shell, shall conform to the contour of the surface at a distance from each surface equal to the smaller of the following:

- (a) $2\frac{1}{2}$ times the nominal shell thickness
 (b) $2\frac{1}{2}$ times the nozzle wall thickness, plus the thickness of any added reinforcement, exclusive of weld metal on the side of the shell under consideration

HG-326.4 Use of Excess Boiler Shell and Other Thicknesses. Metal that may be included as contributing to the area of reinforcement required by HG-321 shall lie within the limits of reinforcement specified in HG-326.2 and HG-326.3 and shall be limited as set forth in (b), (c), (d), and (e) below (see Figure HG-326.2).

(a) *Notation.* The symbols used in this paragraph are defined as follows:

A_1 = area in excess thickness in the boiler shell available for reinforcement

A_2 = area in excess thickness in the nozzle wall available for reinforcement

D_p = outside diameter of reinforcing element (actual size of reinforcing element may exceed the limits of available reinforcement established by HG-326; however, credit cannot be taken for any material outside these limits)

d = diameter in the plane under consideration of the finished opening (see HG-321.2 and Figure HG-326.1)

E_1 = 1 when an opening is in the solid plate or when the opening passes through a circumferential joint in a shell or cone (exclusive of head-to-shell joints)
 = the joint efficiency obtained when any part of the opening passes through any other welded joint

F = factor F from HG-321.2 and Figure HG-321

f_r = strength reduction factor, not greater than 1.0 (see HG-327.1)

f_{r1} = S_n/S_v for nozzle inserted through the vessel wall
 = 1.0 for nozzle wall abutting the vessel wall [see Figure HG-326.1 sketches (a-1), (a-2), and (a-3)]

f_{r2} = S_n/S_v

f_{r3} = (lesser of S_n or S_p)/ S_v

f_{r4} = S_p/S_v

h = distance nozzle projects beyond the inner surface of the vessel wall (extension of the nozzle beyond the inside surface of the vessel wall is not limited; however, for reinforcement calculations the dimension shall not exceed the smaller of $2.5t$ or $2.5t_n$ without a reinforcing element and the smaller of $2.5t$ or $2.5t_n + t_e$ with a reinforcing element or integral compensation)

R_n = inside radius of the nozzle under consideration
 S = maximum allowable stress value taken from Section II, Part D, Table 6A or Table 6B

S_n = allowable stress in nozzle (see S above)

S_p = allowable stress in reinforcing element (plate) (see S above)

S_v = allowable stress in vessel (see S above)

t = nominal thickness of the boiler shell

t_e = thickness of attached reinforcing pad or height of the largest 60 deg right triangle supported by the vessel and nozzle outside diameter projected surfaces and lying completely within the area of integral reinforcement (see Figure HG-326.1)

t_n = nominal thickness of nozzle wall

t_r = required thickness of a seamless shell or head as defined in HG-321

t_{rn} = required thickness of a seamless nozzle wall

Figure HG-326.1
Some Representative Configurations Describing the Reinforcement Dimension, t_e , and the Finished Opening Dimension, d

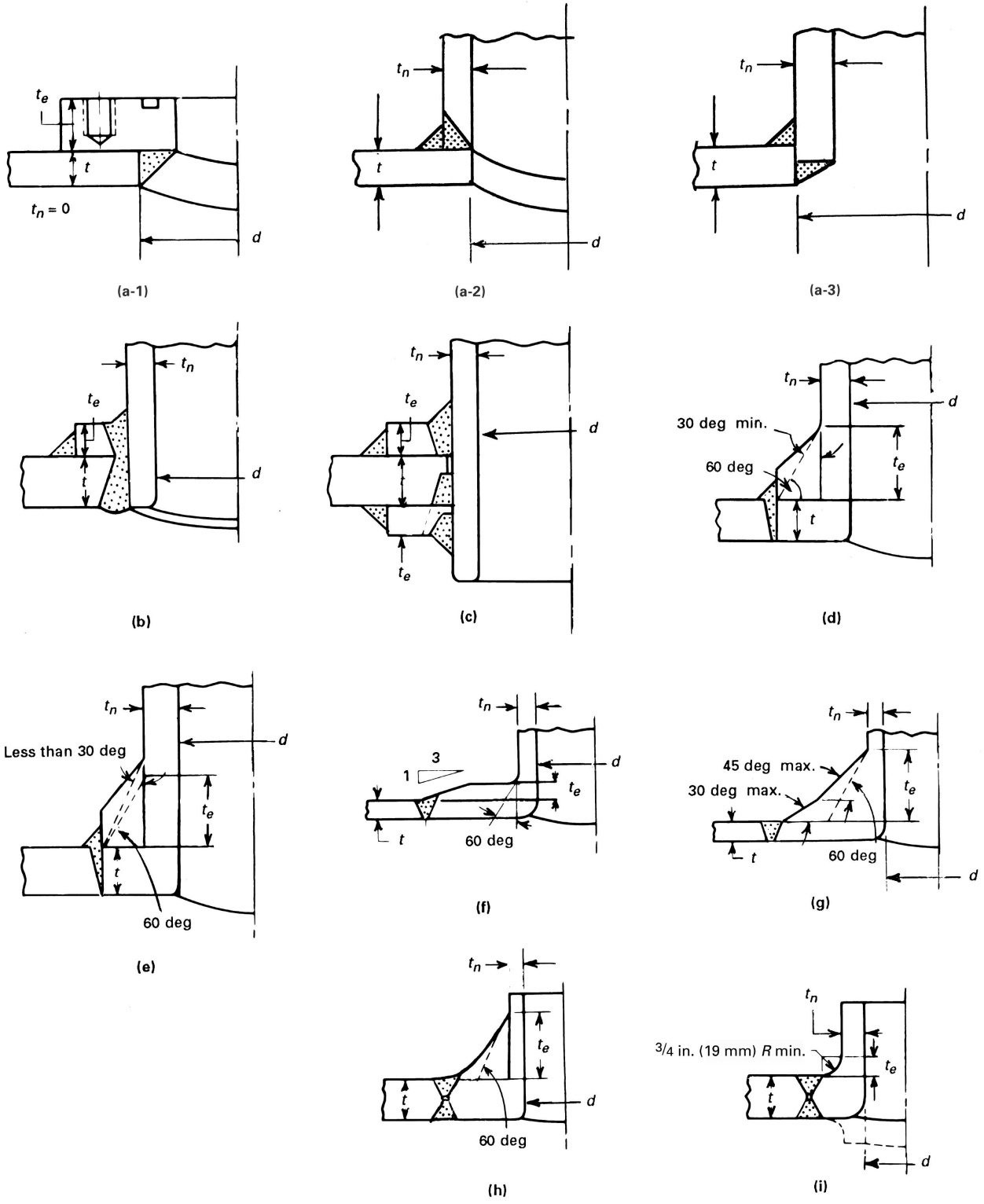

(b) *Metal in the Boiler Shell Over and Above the Thickness Required to Resist Pressure.* The area of the boiler shell available as reinforcement that shall be used is the larger of the values of A_1 given by the equations in [Figure HG-326.2](#).

(c) Metal in the nozzle wall over and above the thickness required to resist pressure in that part of a nozzle wall extending outside the boiler shell. The maximum area in the nozzle wall available as reinforcement in the portion extending outside the boiler shell is the smaller of the values of A_2 given by the equations in [Figure HG-326.2](#). All metal in the nozzle wall extending inside the boiler shell, designated as A_3 in [Figure HG-326.2](#), may be included. No allowance shall be taken for the fact that a differential pressure on an inwardly extending nozzle may cause opposing stress to that of the stress in the shell around the opening.

(d) Metal in the attachment welds, designated as A_4 in [Figure HG-326.2](#), may be included.

(e) Metal added as reinforcement, designated as A_5 in [Figure HG-326.2](#), may be included.

HG-327 STRENGTH OF REINFORCEMENT

HG-327.1 Strength of Nozzle and Added Material. Material in the nozzle wall and added material used for reinforcement shall preferably be the same as that of the boiler shell, but if material with a lower allowable stress value is used, the area provided by such material shall be increased in proportion to the inverse ratio of the allowable stress values of the reinforcement and the boiler shell material. No advantage may be taken of the increased strength of reinforcement material having a higher allowable stress value than the material of the boiler shell. Deposited weld metal outside of either the boiler shell or any reinforcing pad used as reinforcement shall be credited with an allowable stress value equivalent to the weaker of the materials connected by the weld. Boiler-to-nozzle or pad-to-nozzle attachment weld metal within the pad may be credited with a stress value equal to that of the boiler shell or pad, respectively.

HG-327.2 Strength of Attachment Material. On each side of the plane defined in [HG-326.1](#), the strength of the attachment joining the boiler shell and reinforcement or any two parts of the attached reinforcement shall be at least equal to the smaller of

(a) the strength in tension of the cross section of the element of reinforcement being considered.

(b) the strength in tension of the area defined in [HG-321](#) less the strength in tension of the reinforcement area that is integral in the boiler shell as permitted by [HG-326.4](#).

(c) the strength of the attachment joint shall be considered for its entire length on each side of the plane of the area of reinforcement defined in [HG-326.1](#). For obround openings, consideration shall also be given to the strength

of the attachment joint on one side of the plane transverse to the parallel sides of the opening that passes through the center of the semicircular end of the opening.

HG-328 REINFORCEMENT FOR MULTIPLE OPENINGS

HG-328.1 When Limits of Reinforcement Overlap. When any two adjacent openings are spaced at less than two times their average diameter so that their limits of reinforcement overlap, the two openings (or similarly for any larger group of openings) shall be provided with reinforcement in accordance with [HG-321](#) with a combined reinforcement that has a strength equal to the combined strength of the reinforcement that would be required for the separate openings. No portion of the cross section shall be considered as applying to more than one opening or be evaluated more than once in a combined area.

HG-328.2 Combined Reinforcement for Multiple Openings. When more than two adjacent openings are to be provided with a combined reinforcement, the minimum distance between centers of any two of these openings shall preferably be at least $1\frac{1}{2}$ times their average diameter, and the area of reinforcement between them shall be at least equal to 50% of the total required for these two openings.

(a) Two adjacent openings as considered under [HG-328.2](#) shall have a distance between centers not less than $1\frac{1}{3}$ times their average diameter.

(b) In lieu of providing reinforcement for individual openings, reinforcement may be provided for any number of closely spaced adjacent openings, in any arrangement, by providing reinforcement for an assumed opening of a diameter enclosing all such openings.

(c) When a group of openings is provided with reinforcement by a thicker section butt welded into the shell or head, the edges of the inserted section shall be tapered as prescribed in [HW-701.1](#).

HG-328.3 When Reinforcing Each of a Series of Openings Is Impractical. When there is a series of tube openings in a boiler and it is impractical to reinforce each opening, the construction will be acceptable provided the ligaments between openings are calculated by the rules given in [HG-350](#).

HG-330 INSPECTION AND ACCESS OPENINGS

HG-330.1 General Inspection Openings.

(a) All boilers shall be provided with suitable manhole openings and handhole or washout plug openings to permit inspection and removal of accumulated sediment.

Figure HG-326.2
Nomenclature and Formulas for Reinforced Openings

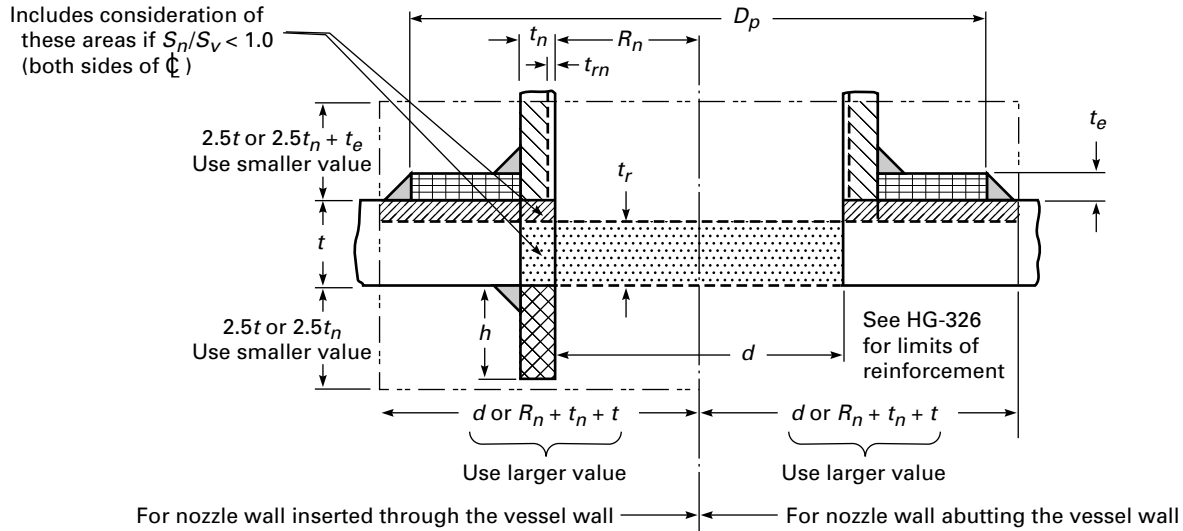

Without Reinforcing Element

	$= A$	$= dt_r F + 2t_n t_r F(1 - f_{r1})$	Area required
	$= A_1$	$\begin{cases} d(E_1 t - F t_r) - 2t_n (E_1 t - F t_r) (1 - f_{r1}) \\ 2(t + t_n) (E_1 t - F t_r) - 2t_n (E_1 t - F t_r) (1 - f_{r1}) \end{cases}$	Area available in shell; use larger value
	$= A_2$	$\begin{cases} 5(t_n - t_{rn}) f_{r2} t \\ 5(t_n - t_{rn}) f_{r2} t_n \end{cases}$	Area available in nozzle projecting outward; use smaller value
	$= A_3$	$= 2t_n f_{r2} h$	Area available in inward nozzle
	$= A_{41}$	$= \text{outward nozzle weld} = (\text{leg})^2 f_{r2}$	Area available in outward weld
	$= A_{43}$	$= \text{inward nozzle weld} = (\text{leg})^2 f_{r2}$	Area available in inward weld
		If $A_1 + A_2 + A_3 + A_{41} + A_{43} > A$	Opening is adequately reinforced
		If $A_1 + A_2 + A_3 + A_{41} + A_{43} < A$	Opening is not adequately reinforced so reinforcing elements must be added and/or thickness must be increased

With Reinforcing Element Added

	A	$= \text{same as } A \text{ above}$	Area required
	A_1	$= \text{same as } A_1 \text{ above}$	Area available
	A_2	$\begin{cases} 5(t_n - t_{rn}) f_{r2} t \\ 2(t_n - t_{rn}) (2.5t_n + t_e) f_{r2} \end{cases}$	Area available in nozzle projecting outward; use smaller area
	A_3	$= \text{same as } A_3 \text{ above}$	Area available in inward nozzle
	$= A_{41}$	$= \text{outward nozzle weld} = (\text{leg})^2 f_{r3}$	Area available in outward weld
	$= A_{42}$	$= \text{outer element weld} = (\text{leg})^2 f_{r4}$	Area available in outer weld
	$= A_{43}$	$= \text{inward nozzle weld} = (\text{leg})^2 f_{r2}$	Area available in inward weld
	$= A_5$	$= (D_p - d - 2t_n) t_e f_{r4}$ [Note (1)]	Area available in element
		If $A_1 + A_2 + A_3 + A_{41} + A_{42} + A_{43} + A_5 > A$	Opening is adequately reinforced

GENERAL NOTE: This figure illustrates a common nozzle configuration and is not intended to prohibit other configurations permitted by the code.

NOTE: (1) This formula is applicable for a rectangular cross-sectional element that falls within the limits of reinforcement.

(b) Electric boilers of a design employing a removable cover that will permit access for inspection and cleaning and having an internal gross volume (exclusive of casing and insulation) of not more than 5 ft³ (0.14 m³) need not be fitted with washout or inspection openings.

Electric boilers equipped with immersion type resistance elements not provided with a manhole shall have an inspection opening or handhole located in the lower portion of the shell or head. The inspection opening shall not be smaller than NPS 3 (DN 80). In addition, electric boilers designed for steam service shall have an inspection opening or manhole at or near the normal waterline.

(c) Furnaces of internally fired boilers shall be provided with access doors as required by HG-330.5.

HG-330.2 Manholes. A manhole shall be placed in the front head below the tubes of a horizontal-return tubular boiler 60 in. (1500 mm) or over in diameter. There shall be a manhole in the upper part of the shell, or in the head of a firetube boiler over 60 in. (1500 mm) in diameter, except in a vertical firetube boiler.

HG-330.3 Size of Manholes and Gasket Surfaces.

(a) An elliptical manhole opening shall not be less than 12 in. × 16 in. (300 mm × 400 mm) in size.

(b) A circular manhole opening shall not be less than 15 in. (380 mm) in diameter.

(c) The minimum width of bearing surface for a gasket on a manhole opening shall be 1¹/₁₆ in. (17 mm).

(d) No gasket for use on a manhole or handhole of any boiler shall have a thickness greater than 1/8 in. (3 mm) when compressed.

HG-330.4 Handholes and Washout Plugs.

(a) Boilers of the locomotive or firebox type, except those set in brick or otherwise so constructed as to render such openings inaccessible, shall have one handhole or washout plug near each corner in the lower part of the waterleg and at least one opening near the line of the crown sheet. In addition, boilers designed for steam service shall have at least one inspection opening above the top row of tubes. This inspection opening shall be a minimum of NPS 3 (DN 80) or a handhole as specified in (f) below and used solely for inspection purposes.

(b) A boiler of the scotch type shall have a handhole or washout plug in the front head below or on each side of the furnace or on each side of the shell near the front head, a handhole or washout plug in the bottom of the shell, an opening to inspect the top of the furnace and an inspection opening above the top row of tubes. This inspection opening shall be a minimum of NPS 3 (DN 80) or a handhole as specified in (f) below and used solely for inspection purposes. Scotch marine boilers (wet-back type) shall also

have an opening for inspection of the water space at the rear of the combustion chamber.

(c) Vertical firetube or similar type boilers having gross internal volume (exclusive of casing and insulation) more than 5 ft³ (0.14 m³) shall have at least three handholes or washout plugs in the lower part of the waterleg and at least two handholes or washout plugs near the line of the lower tubesheet. Such boilers having gross internal volume not over 5 ft³ (0.14 m³) shall have at least two washout openings in the lower part of the waterleg and at least one washout opening near the line of the lower tubesheet. In addition, boilers designed for steam service shall have at least one inspection opening above the lowest permissible water level. This inspection opening shall be a minimum of NPS 3 (DN 80) or a handhole as specified in (f) below and used solely for inspection purposes.

(d) Washout plugs shall be not smaller than NPS 1¹/₂ (DN 40) for boilers having gross internal volume more than 5 ft³ (0.14 m³). Washout plugs shall be not smaller than NPS 1 (DN 25) for boilers having gross internal volume not more than 5 ft³ (0.14 m³).

(e) Washout openings may be used for return pipe connections and the washout plug placed in a tee so that the plug is directly opposite and as close as possible to the opening in the boiler.

(f) A handhole opening shall not be less than 2³/₄ in. × 3¹/₂ in. (70 mm × 89 mm) but it is recommended that, where possible, larger sizes be used.

HG-330.5 Access Doors.

(a) A fire door or other access not less than 11 in. × 15 in. (280 mm × 380 mm) or 10 in. × 16 in. (250 mm × 400 mm) or 15 in. (381 mm) in diameter, shall be provided for the furnace of an internally fired boiler in that the least furnace dimension is 28 in. (711 mm) or over. The minimum size of access door used in a boiler setting shall be 12 in. × 16 in. (300 mm × 400 mm), or equivalent area, the least dimension being 11 in. (280 mm).

(b) *Fuel Burning Equipment.* Fuel burning equipment may be installed in the fire door opening provided the cover plate can be unbolted or unlatched to give full-size access to the furnace through the fire door opening.

HG-340 STAYED SURFACES

HG-340.1 Required Thickness and Design Pressure.

(a) The required thickness and design pressure for stayed flat plates and those parts that, by these rules, require staying, as flat plates with stays or staybolts of uniform cross section that are symmetrically spaced, shall be calculated by the following equations:

Figure HG-340.1
Pitch of Staybolts Adjacent to Upper Corners of Fireboxes

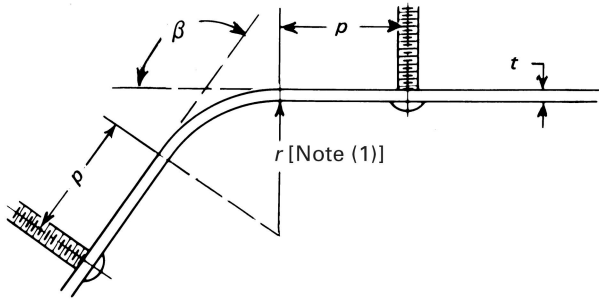

NOTE: (1) Maximum $r = p$ as calculated by HG-340.5; minimum $r = 3t$. If the radius, r , exceeds the pitch, the curved plate shall be stayed as a flat plate in accordance with HG-340.

$$t = p\sqrt{P/SC} \quad (1)$$

$$P = t^2SC/p^2 \quad (2)$$

where

- $C = 2.7$ for stays welded to plates or for stays screwed through plates not over $7/16$ in. (11 mm) in thickness, with ends riveted over
 - $= 2.8$ for stays welded to plates or for stays screwed through plates over $7/16$ in. (11 mm) in thickness, with ends riveted over
 - $= 3.1$ for stays screwed through plates and fitted with single nuts outside of plate, or with inside and outside nuts, omitting washers
 - $= 3.5$ for stays with heads not less than 1.3 times the diameter of the stays screwed through plates, or made a taper fit and having the heads formed on the stays before installing them and not riveted over, said heads being made to have a true bearing on the plate
 - $= 4.0$ for stays fitted with inside and outside nuts and outside washers where the diameter of washers is not less than $0.4p$ and thickness not less than t
- P = design pressure
 p = maximum pitch measured between straight lines passing through the centers of the stays in the different rows, which lines may be horizontal, vertical, or inclined
 r = radius of firebox corner
 S = maximum allowable stress value given in Section II, Part D, Table 6A or Table 6B
 t = required thickness of plate

(b) When two flat stayed surfaces intersect at an angle as shown in Figure HG-340.1, the pitch from the staybolt nearest to the intersection to the point of tangency of the corner curve with the plate shall be

$$p = \frac{90t}{\beta} \sqrt{\frac{CS}{P}}$$

where β is the angle shown in Figure HG-340.1. In the application of this rule, β shall be limited to between 90 deg and 180 deg inclusive.

(c) When two plates are connected by stays and only one of these plates requires staying, the value of C shall be governed by the thickness of the plate requiring staying.

HG-340.2 Proportions of Through-Stays With Washers Acceptable proportions for the ends of through-stays with washers are indicated in Figure HG-340.2.

HG-340.3 Maximum Pitch of Stays. The maximum pitch shall be $8\frac{1}{2}$ in. (216 mm) except that for welded-in stays the pitch may be greater provided it does not exceed 15 times the diameter of the stay.

HG-340.4 Unsymmetrical Staying. Where the staying of shells is unsymmetrical by reason of the construction, it is permissible to consider the load carried by each stay as that on the area calculated by taking the distance from the center of the spacing on one side of the stay to the center of the spacing on the other side.

Figure HG-340.2
Acceptable Proportions for Ends of Through-Stays

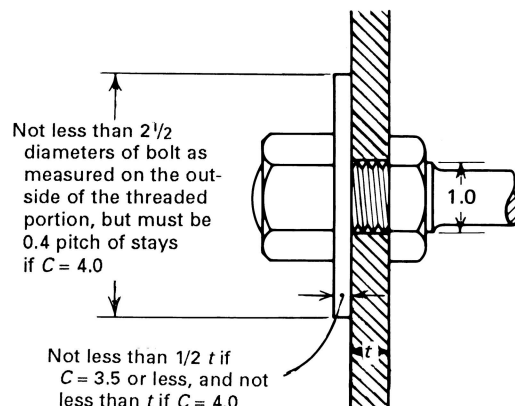
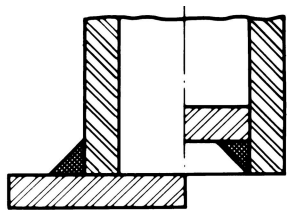

Figure HG-340.3
Examples of Acceptable Corner Welds for Pressures
Not Over 30 psi



HG-340.5 Stay Distance to Corner Joints, Welded Joints, and Flanges.

(a) In the construction of a heating boiler designed for not over 30 psi (200 kPa) and having welded joints, the allowable distance from a corner-welded joint to the nearest row of stays may be a full pitch as provided by the formula in [HG-340.1](#). A welded joint in a flat surface shall be between two rows of stays that are not over one pitch apart except that the type of joint shown in [Figure HG-340.3](#) shall have a row of stays not more than one pitch from the weld.

(b) In the construction of heating boilers to be designed for water pressures above 30 psi (200 kPa), corner joints shall comply with the requirements of [HW-701.3](#).

(c) When the edge of a flat stayed plate is flanged, the distance from the center of the outermost stays to the inside of the supporting flange shall not be greater than the pitch of the stays plus the inside radius of the flange.

HG-340.6 Allowable Pitch of Stays. The allowable pitch for stays as given in [Table HG-340](#) may be used in place of the pitch calculated under [HG-340.1](#) when the allowable stress of the steel is 11,000 psi (76 MPa) or greater.

HG-341 STAYBOLTS

HG-341.1 Threaded Staybolts. The ends of staybolts extending through the plate shall extend beyond the plate not less than two threads when installed, after which they shall be riveted over or upset by an equivalent process without excessive scoring of the plate, or they may be fitted with threaded nuts through which the staybolt shall extend. The outside ends of solid staybolts 8 in. (200 mm) or less in length, if of uniform diameter throughout their length, shall be drilled with telltale holes at least $\frac{3}{16}$ in. (5 mm) in diameter to a depth extending at least $\frac{1}{2}$ in. (13 mm) beyond the inside of the plate. If such staybolts are reduced in section below their diameter at the root of the thread, the telltale holes shall extend at least $\frac{1}{2}$ in.

(13 mm) beyond the point where the reduction in section commences. Hollow staybolts may be used in place of solid staybolts with drilled ends. Solid staybolts over 8 in. (200 mm) long need not be drilled. Staybolts used in waterlegs of watertube boilers shall be hollow or drilled at both ends, in accordance with the requirements above stated, irrespective of their length. All threaded staybolts not normal to the stayed surface shall have not less than three engaging threads of which at least one shall be a full thread; but if the thickness of the material in the boiler is not sufficient to give one full engaging thread, the plates shall be sufficiently reinforced on the inside by a steel plate welded thereto. Telltale holes are not required in staybolts attached by welding.

HG-341.2 Staybolts Upset for Threading. The ends of steel stays upset for threading shall be fully annealed after upsetting.

HG-341.3 Staybolts Fitted With Nuts. The ends of staybolts fitted with nuts shall not be exposed to direct radiant heat from fire.

HG-341.4 Welded-In Staybolts. Requirements for welded-in staybolts are given in [HW-710](#).

HG-342 DIMENSIONS OF STAYS

HG-342.1 Required Area of Stays. The required area of a stay at its minimum cross section (usually at the root of the thread) and exclusive of any allowance for corrosion shall be obtained by dividing the load on the stay computed in accordance with [HG-342.2](#), [HG-342.3](#), and [HG-342.4](#) by the allowable stress value for the material.

HG-342.2 Load Carried by Stays. The area supported by a stay shall be computed on the basis of the full pitch dimensions with a deduction for the area occupied by the stay. The load carried by a stay is the product of the area supported by the stay and the design pressure.

HG-342.3 Stays Longer Than 120 Diameters. Stays exceeding 120 diameters in length shall be supported at intervals not exceeding 120 diameters or the cross-sectional area of the stay shall be increased by not less than 15% of the required area of the stays calculated in [HG-342.1](#).

HG-342.4 Stays Fabricated by Welding. Stays made of parts jointed by welding shall be computed for strength using a joint efficiency of 60% for the weld. Welded stays shall be used only where it is impractical to use stays of one-piece construction.

Table HG-340
Allowable Pitch [Note (1)] of Stays, in. (mm) (Limited by HG-340.3)

Design Pressure, psi (kPa)	Plate Thickness, in. (mm)							
	1/4 (6.4)	9/32 (7.1)	5/16 (7.9)	11/32 (8.7)	3/8 (9.5)	13/32 (10.3)	7/16 (11.1)	15/32 (11.9)
30 (207)	7 7/8 (200)	8 13/16 (224)	9 13/16 (249)	10 13/16 (275)	11 13/16 (300)	12 3/4 (324)	13 3/4 (349)	15 (381)
40 (276)	6 13/16 (173)	7 5/8 (194)	8 1/2 (216)	9 3/8 (238)	10 3/16 (259)	11 1/16 (281)	11 15/16 (303)	13 (330)
50 (345)	6 1/16 (154)	6 7/8 (175)	7 5/8 (194)	8 3/8 (213)	9 1/8 (232)	9 7/8 (251)	10 5/8 (270)	11 5/8 (295)
60 (414)	5 9/16 (141)	6 1/4 (159)	6 15/16 (176)	7 5/8 (194)	8 5/16 (211)	9 (229)	9 3/4 (248)	10 5/8 (270)
70 (483)	5 1/8 (130)	5 13/16 (148)	6 7/16 (164)	7 1/16 (179)	7 11/16 (195)	8 3/8 (213)	9 (229)	9 13/16 (249)
75 (517)	4 15/16 (125)	5 9/16 (141)	6 1/4 (159)	6 13/16 (173)	7 7/16 (189)	8 1/16 (205)	8 11/16 (221)	9 1/2 (241)
80 (552)	4 13/16 (122)	5 3/8 (137)	6 (152)	6 5/8 (168)	7 3/16 (183)	7 13/16 (198)	8 7/16 (214)	9 3/16 (233)
90 (621)	4 9/16 (116)	5 1/8 (130)	5 11/16 (144)	6 1/4 (159)	6 13/16 (173)	7 3/8 (187)	7 15/16 (202)	8 11/16 (221)
100 (690)	4 5/16 (110)	4 13/16 (122)	5 3/8 (137)	5 15/16 (151)	6 7/16 (164)	7 (178)	7 1/2 (191)	8 3/16 (208)
110 (758)	...	4 5/8 (117)	5 1/8 (130)	5 5/8 (143)	6 1/8 (156)	6 11/16 (170)	7 3/16 (183)	7 13/16 (198)
120 (827)	...	4 7/16 (113)	4 7/8 (124)	5 3/8 (137)	5 7/8 (149)	6 3/8 (162)	6 7/8 (175)	7 1/2 (191)
125 (862)	...	4 5/16 (110)	4 13/16 (122)	5 5/16 (135)	5 3/4 (146)	6 1/4 (159)	6 3/4 (171)	7 3/8 (187)
130 (896)	5 3/16 (132)	5 5/8 (143)	6 1/8 (156)	6 5/8 (168)	7 3/16 (183)
140 (965)	5 (127)	5 7/16 (138)	5 7/8 (149)	6 3/8 (162)	6 15/16 (176)
150 (1034)	4 13/16 (122)	5 1/4 (133)	5 11/16 (144)	6 1/8 (156)	6 11/16 (170)
160 (1103)	4 11/16 (119)	5 1/8 (130)	5 1/2 (140)	5 15/16 (151)	6 1/2 (165)
Design Pressure, psi (kPa)	Plate Thickness, in. (mm)							
	1/2 (12.7)	17/32 (13.5)	9/16 (14.3)	19/32 (15.1)	5/8 (15.9)	21/32 (16.7)	11/16 (17.5)	3/4 (19.1)
30 (207)	16 (406)	17 (432)	18 (457)	19 (483)	20 (508)	21 (533)	22 (559)	24 (610)
40 (276)	13 7/8 (352)	14 3/4 (375)	15 11/16 (398)	16 7/16 (418)	17 7/16 (440)	18 3/16 (462)	19 1/16 (484)	20 13/16 (529)
50 (345)	12 3/8 (314)	13 3/16 (335)	13 15/16 (354)	14 3/4 (375)	15 1/2 (394)	16 1/4 (413)	17 1/16 (433)	18 5/8 (473)
60 (414)	11 5/16 (287)	11 15/16 (303)	12 3/4 (324)	13 7/16 (341)	14 1/8 (359)	14 7/8 (378)	15 9/16 (395)	17 (432)
70 (483)	10 1/2 (267)	11 1/8 (283)	11 13/16 (300)	12 7/16 (316)	13 1/8 (333)	13 3/4 (349)	14 3/8 (365)	15 11/16 (398)
75 (517)	10 1/8 (257)	10 3/4 (273)	11 3/8 (289)	12 (305)	12 5/8 (321)	13 5/16 (338)	13 15/16 (354)	15 3/16 (386)
80 (552)	9 13/16 (249)	10 7/16 (265)	11 (279)	11 5/8 (295)	12 1/4 (311)	12 7/8 (327)	13 1/2 (343)	14 11/16 (373)
90 (621)	9 1/4 (235)	9 13/16 (249)	10 3/8 (264)	11 (279)	11 9/16 (294)	12 1/8 (308)	12 11/16 (322)	13 7/8 (352)
100 (690)	8 3/4 (222)	9 5/16 (237)	9 7/8 (251)	10 3/8 (264)	10 15/16 (278)	11 1/2 (292)	12 1/16 (306)	13 1/8 (333)
110 (758)	8 3/8 (213)	8 7/8 (225)	9 3/8 (238)	9 15/16 (252)	10 7/16 (265)	11 (279)	11 1/2 (292)	12 9/16 (319)
120 (827)	8 (203)	8 1/2 (216)	9 (229)	9 1/2 (241)	10 (254)	10 1/2 (267)	11 (279)	12 (305)
125 (862)	7 13/16 (198)	8 5/16 (211)	8 7/8 (225)	9 5/16 (237)	9 13/16 (249)	10 5/16 (262)	10 3/4 (273)	11 3/4 (198)
130 (896)	7 11/16 (195)	8 3/16 (208)	8 5/8 (219)	9 1/8 (232)	9 5/8 (244)	10 1/8 (257)	10 9/16 (268)	11 1/2 (292)
140 (965)	7 3/8 (187)	7 7/8 (200)	8 5/16 (211)	8 13/16 (224)	9 1/4 (235)	9 3/4 (248)	10 3/16 (259)	11 1/8 (283)
150 (1034)	7 1/8 (181)	7 5/8 (194)	8 1/16 (205)	8 1/2 (216)	8 15/16 (227)	9 3/8 (238)	9 13/16 (249)	10 3/4 (273)
160 (1103)	6 15/16 (176)	7 3/8 (187)	7 13/16 (198)	8 1/4 (210)	8 11/16 (221)	9 1/16 (230)	9 1/2 (241)	10 7/16 (265)

NOTE: (1) The pitches in Table HG-340 are calculated from the equation $p = \sqrt{t^2 \times SC/P}$. In calculating these pitches, $C = 2.7$ for plate thicknesses not over 7/16 in. and $C = 2.8$ for plate thicknesses exceeding 7/16 in.; $S = 11,000$ psi.

HG-342.5 Minimum Cross-Sectional Area. No ferrous screwed stay, or ferrous stay welded in by the fusion process of welding shall have a cross-sectional area less than 0.44 in.^2 (284 mm^2).

HG-342.6 Minimum Diameter of Nonferrous Stays.

(a) For nonferrous staybolted construction using unthreaded copper staybolts and copper plates, the minimum diameter of the staybolts shall be as follows:

Copper Plate Thickness, in. (mm)	Min. Staybolt Diameter, in. (mm)
Not exceeding $\frac{1}{8}$ (3)	$\frac{1}{2}$ (13)
Over $\frac{1}{8}$ (3), but not over $\frac{3}{16}$ (5)	$\frac{5}{8}$ (16)
Over $\frac{3}{16}$ (5)	$\frac{3}{4}$ (19)

(b) For nonferrous staybolted construction using unthreaded copper-nickel staybolts and copper-nickel plates, the minimum diameter of staybolts shall be as follows:

Copper-Nickel Plate Thickness, in. (mm)	Min. Staybolt Diameter, in. (mm)
Not exceeding $\frac{1}{8}$ (3)	$\frac{3}{8}$ (10)
Over $\frac{1}{8}$ (3), but not over $\frac{3}{16}$ (5)	$\frac{7}{16}$ (11)
Over $\frac{3}{16}$ (5)	$\frac{1}{2}$ (13)

HG-343 DIMENSIONS OF DIAGONAL STAYS

HG-343.1 Required Area of Diagonal Stays. To determine the required area of a diagonal stay, multiply the area of the direct stay, required to support the surface, by the slant or diagonal length of the stay; divide this product by the length of a line (drawn perpendicular to the surface supported) to the center of the palm of the diagonal stay, as follows:

$$A = \frac{aL}{l}$$

where

- A = sectional area of diagonal stay, in.^2 (mm^2)
- a = sectional area of direct stay, in.^2 (mm^2)
- L = length of diagonal stay as indicated in [Figure HG-343](#), in. (mm)
- l = length of line, drawn perpendicular to boiler head or surface supported, to center of palm of diagonal stay, as indicated in [Figure HG-343](#), in. (mm)

Example:

Given diameter of direct stay = 1 in., $a = 0.7854 \text{ in.}^2$, $L = 60 \text{ in.}$, $l = 48 \text{ in.}$; substituting and solving:

$$A = \frac{0.7854 \times 60}{48} = 0.98 \text{ sectional area, in.}^2$$

Diameter = 1.11 in. (use $1\frac{1}{8}$ in.)

HG-343.2 Diagonal Stays for Segments of Tubesheets. For staying segments of tubesheets such as in horizontal firetube boilers, where L is not more than 1.15 times l for any stay, the stays may be calculated as direct stays using 90% of the allowable stress values calculated in [HG-342.1](#).

HG-345 STAYING OF HEADS

HG-345.1 General.

(a) Those portions of heads that require staying shall be stayed as flat plates under the provisions of these rules.

(b) For unflanged heads in boilers designed for not over 30 psi (200 kPa) pressure, with the heads attached with single fillet welds in accordance with [HW-701.3\(a\)](#), staying is not required if the greatest distance measured along a radial line from the inner surface of the shell to a fully supported line does not exceed $1.25p$. For unflanged heads in boilers designed for over 30 psi (200 kPa) with heads attached in accordance with [HW-701.3\(b\)](#), or for flanged heads of any pressure, staying is not required if the greatest distance measured as above does not exceed $1.5p$. The value of p shall be obtained by applying the equation of [HG-340](#) with a C value of 2.7 or 2.8 depending on the plate thickness.

(c) For purposes of applying the above paragraph, a fully supported line is a flanged or welded corner joint or is a line tangent to a row of tubes not over one pitch apart between edges and extending to within one pitch of the shell or the diametrically opposite side of the shell.

(d) For unflanged heads, the maximum distance between the inner surface of the shell and the centers of stays shall not be more than the allowable pitch as determined by [HG-340](#), using the value of C given for the thickness of plate and the type of stay used.

(e) For a flanged head welded to the shell, the maximum distance between the inner surface of the supporting flange and lines parallel to the surface of the shell passing through the centers of the stays shall be p as determined by the formula in [HG-340](#), plus the inside radius of the supporting flange, using the value of C given for the thickness of plate and the type of stay used.

(f) The maximum distance between the edges of the tube holes and the center of the first row of stays shall be p as determined by the formula in [HG-340](#), using the value of C given for the thickness of plate and the type of stay used.

Figure HG-343
Details of Installation of Diagonal Stays

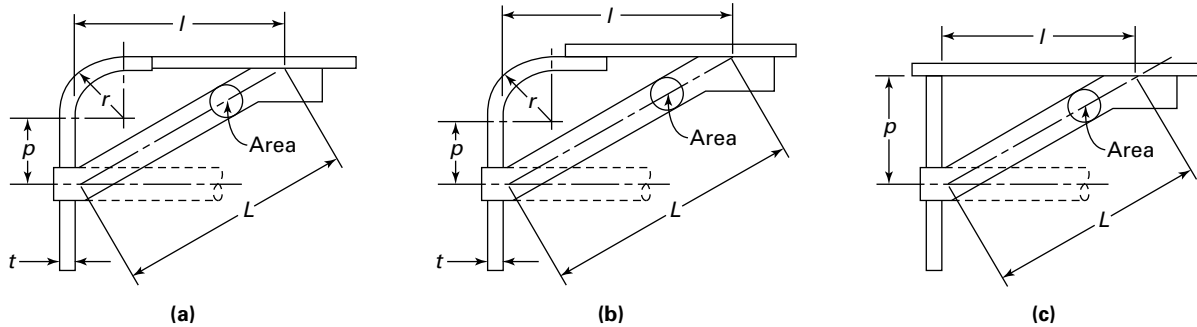

GENERAL NOTES:

- (a) Determine area of diagonal stays per [HG-343.1](#).
 (b) Determine weld details and weld size for stay-to-tube-sheet and stay-to-shell per [HW-710](#).
 (c) Determine diagonal stay pitch per [HG-340.1](#).
 (d) Maximum $r = 8t$; minimum $r = 3t$; t = nominal thickness of tubesheet.

(g) When a portion of the head in a horizontal firetube boiler is provided with a manhole opening, the flange of which is formed from the solid plate and turned inward to a depth of not less than three times the required thickness of the head, measured from the outside or, when an unflanged manhole ring meeting the requirements of [HG-321](#) is provided in a flat stayed head of a firetube boiler, the area to be stayed may be reduced by 100 in.² (645 cm²) provided both the following requirements are met [see [Figures HG-345.1\(a\)](#) and [HG-345.1\(b\)](#)]:

(1) The distance between the manhole opening and the inner surface of the supporting flange does not exceed one-half the maximum allowable pitch for an unflanged manhole or one-half the maximum allowable pitch plus the inside radius of the supporting flange for a flanged-in manhole in a flanged head.

(2) The distance between the centers of the first row of stays, or the edges of the tube holes, and the manhole opening does not exceed one-half the maximum allowable pitch as determined by [HG-340](#).

HG-346 TUBESHEETS WITH FIRETUBES USED AS STAYS

HG-346.1 Required Thickness, Maximum Pitch, and Design Pressure. The required thickness, maximum pitch, and design pressure for tubesheets with firetubes used as stays shall be calculated using the following equations:

$$t = \sqrt{\left(\frac{P}{CS}\right)\left(p^2 - \frac{\pi D^2}{4}\right)} \quad (1)$$

$$p = \sqrt{\left(\frac{CS t^2}{P}\right) + \left(\frac{\pi D^2}{4}\right)} \quad (2)$$

$$P = \frac{CS t^2}{p^2 - \left(\frac{\pi D^2}{4}\right)} \quad (3)$$

where

$C = 2.7$ for tubesheets not over $\frac{7}{16}$ in. (11 mm) thick
 $= 2.8$ for tubesheets over $\frac{7}{16}$ in. (11 mm) thick

D = outside diameter of the tube

P = design pressure

p = maximum pitch measured between the centers of tubes in different rows, which lines may be horizontal, vertical, or inclined

S = maximum allowable stress value given in Section II, Part D, Table 6A or Table 6B

t = required thickness of plate

HG-346.2 Maximum Pitch of Firetubes Used as Stays. The pitch of firetubes used as stays shall not exceed 15 times the diameter of the tube.

HG-346.3 Calculating Firetubes Used as Stays. No calculation need be made to determine the availability of the required cross-sectional area or the maximum allowable pitch for tubes within or on the perimeter of a nest of tubes, which are spaced at less than twice their average diameter.

Figure HG-345.1(a)
Sketch Showing Application of HG-345.1 to the Staying of Boilers

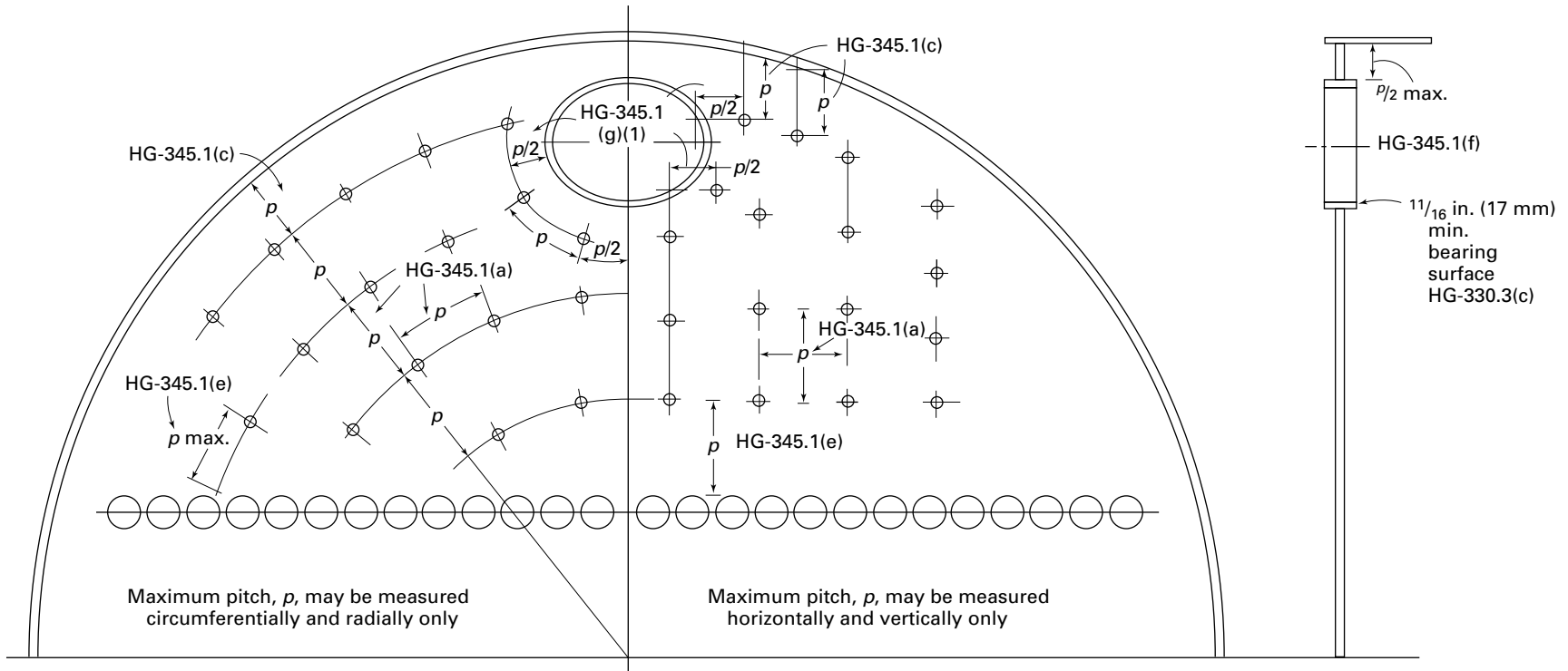

27

GENERAL NOTES:

- (a) Required cross-sectional area to carry total load on segment based upon allowable stresses from Section II, Part D, Table 6A or Table 6B and computed by HG-342.1.
- (b) Provide the number of stays required to not exceed the maximum calculated pitch.
- (c) Diagonal stay stresses must not exceed limits computed from HG-343.1.

Figure HG-345.1(b)
Sketch Showing Application of HG-345.1 to the Staying of Boilers

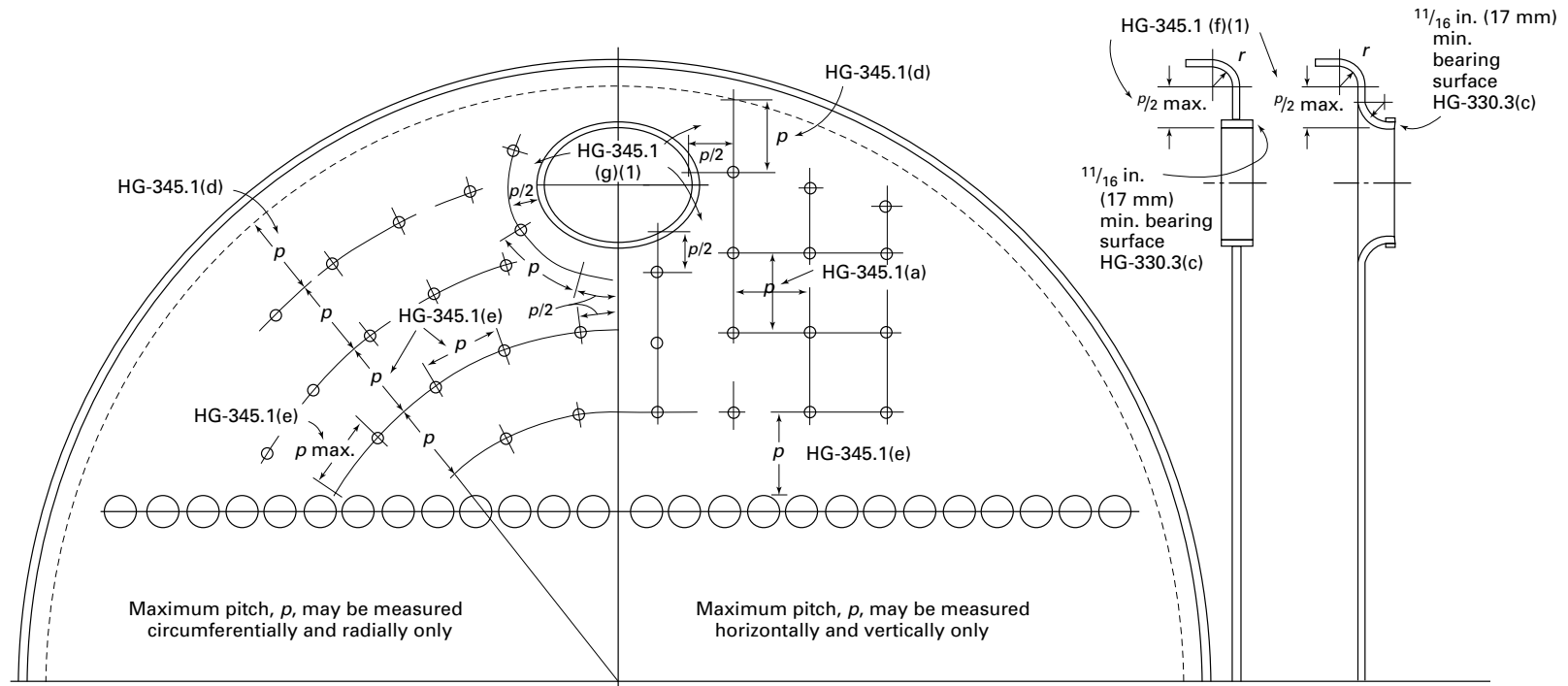

GENERAL NOTE:

- (a) Required cross-sectional area to carry total load on segment based upon allowable stresses from Section II, Part D, Table 6A or Table 6B and computed by [HG-342.1](#).
- (b) Provide the number of stays required to not exceed the maximum calculated pitch.
- (c) Diagonal stay stresses must not exceed limits computed from [HG-343.1](#).

HG-346.4 Dimensions and Welding of Firetubes Used as Stays.

(a) The dimensions of firetubes used as stays shall meet the requirements of HG-301.2 and HG-342.

(b) Firetubes used as stays may be attached by any method permitted in HG-360.2.

(c) Firetubes welded to the tubesheet and used as stays shall meet the requirements of HW-713.

HG-350 LIGAMENTS

HG-350.1 General. The rules in this paragraph apply to groups of openings that form a definite pattern in cylindrical pressure parts and to openings spaced not more than two diameters center to center.

(a) The symbols defined below are used in the equations of this paragraph:

- d = diameter of openings
- E = efficiency of ligament
- n = number of openings in length p_1
- p = longitudinal pitch of adjacent openings
- p_1 = pitch between corresponding openings in a series of symmetrical groups of openings
- p' = diagonal pitch of adjacent openings
- p'' = transverse pitch of adjacent openings

(b) The efficiency of ligaments between openings is defined as the ratio of the average strength of the material between adjacent openings to the average strength of the plate away from the openings. Where a series of openings has more than one efficiency, the lowest value shall govern.

(c) The pitch shall be measured on the flat plate before rolling.

HG-350.2 Openings Parallel to Shell Axis. The ligament efficiency shall be determined as follows.

(a) For equal pitch of openings in every row (see Figure HG-350.1), the efficiency is given by the formula:

$$E = \frac{p - d}{p} \tag{1}$$

(b) For unequal pitch in definite repeating patterns (as in Figures HG-350.2 and HG-350.3), the efficiency is given by the formula:

$$E = \frac{p_1 - nd}{p_1} \tag{2}$$

(c) For openings that do not form a definite repeating pattern, the efficiency shall be the value calculated as follows for the group of openings that gives the lowest efficiency:

(1) the efficiency given by (b), eq. (2) above using p_1 less than or equal to the inside diameter of the shell or 60 in. (1500 mm), whichever is less

(2) 1.25 times the efficiency given by (b), eq. (2) above using p_1 less than or equal to the inside radius of the shell or 30 in. (750 mm), whichever is less

HG-350.3 Openings Transverse to Shell Axis.

The ligament efficiency of openings spaced at right angles to the axis of the shell is equal to two times the efficiency of similarly spaced holes parallel to the shell axis as calculated in accordance with the rules in HG-350.2.

HG-350.4 Holes Along a Diagonal. The ligament efficiency shall be determined as follows.

(a) The efficiency of openings that are equally spaced along diagonal lines (see Figure HG-350.4) is given by the formula:

$$E = \frac{p' - d}{p' F} \tag{3}$$

where F is a factor from Figure HG-321 for the angle that the diagonal makes with a plane through the longitudinal axis of the boiler.

(b) The ligament efficiency of openings that are unequally spaced along diagonal lines shall be determined as in HG-350.1(c) except that (a), eq. (3) shall be used in place of HG-350.2(b), eq. (2).

HG-360 REQUIREMENTS FOR TUBE HOLES AND TUBE ATTACHMENTS

HG-360.1 Tube Holes and Ends. Tube holes in solid plate may be drilled, punched, punched and shaved, laser cut, thermal cut, plasma-arc cut, or cut with a high-pressure water jet. (23)

(a) Tube holes for use with tube ends attached by welding shall be fabricated using one of the following methods:

- (1) drilled full size from the solid plate

Figure HG-350.1
Example of Tube Spacing With Pitch of Holes Equal in Every Row

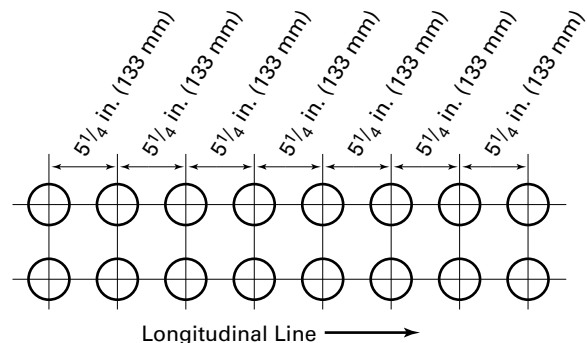
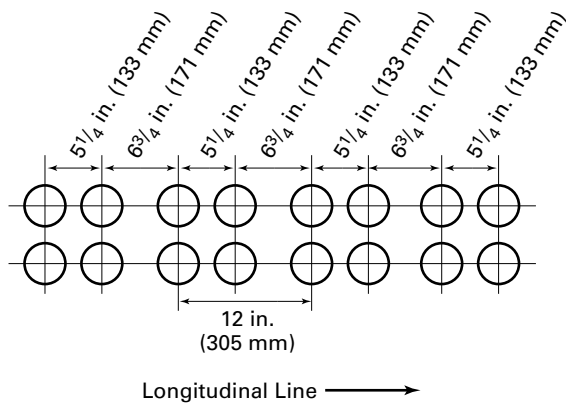

Figure HG-350.2
Example of Tube Spacing With Pitch of Holes
Unequal in Every Second Row



(2) punched full size from the solid plate or punched smaller in diameter than full size then drilled, shaved, reamed, or finished full size with rotating cutters

(3) laser, thermal, or plasma-arc cut full size from the solid plate or cut smaller in diameter than full size then drilled, shaved, reamed, or finished full size with rotating cutters

(4) cut full size with a high-pressure water jet from the solid plate or cut smaller in diameter than full size then drilled, shaved, reamed, or finished full size with rotating cutters

(b) Tube holes for use with tube ends attached by expanding shall be fabricated using one of the following methods:

(1) drilled full size from the solid plate

(2) punched from solid plate $\frac{1}{2}$ in. (13 mm) smaller in diameter than full size when the plate thickness exceeds $\frac{3}{8}$ in. (10 mm) and $\frac{1}{8}$ in. (3 mm) smaller in diameter than full size when the plate thickness is $\frac{3}{8}$ in. (10 mm) or less. Tube holes shall then be drilled, shaved, reamed, or finished full size with rotating cutters.

(3) laser, thermal or plasma-arc cut in solid plate sufficiently smaller in diameter than full size, such that subsequent machining to full size shall completely remove all metal whose mechanical and metallurgical properties have been affected as a result of the cutting process. Tube holes shall then be drilled, shaved, reamed, or finished full size with rotating cutters.

(4) cut with a high-pressure water jet from the solid plate smaller in diameter than full size, such that subsequent machining to full size shall completely remove all surface discontinuities in the metal as a result of the cutting process. Tube holes shall then be drilled, shaved, reamed, or finished full size with rotating cutters.

(c) Where thermal cutting is used, the effect on the mechanical and metallurgical properties of the base metal shall be taken into consideration.

(d) When using the shaving process, the following guidelines shall be met:

(1) When the plate thickness exceeds $\frac{3}{8}$ in. (10 mm), the incremental material removal shall not exceed a maximum of 0.120 in. (3 mm). The final finishing step shall not remove more than 0.020 in. (0.5 mm) at one time.

(2) When the plate thickness is $\frac{3}{8}$ in. (10 mm) or less, the incremental material removal shall not exceed a maximum of 0.060 in. (1.5 mm). The final finishing step shall not remove more than 0.020 in. (0.5 mm) at one time.

(e) The base metal preparation shall leave the tube hole with a smooth surface free from deep notches, striations, or irregularities.

(f) Tube holes may be counterbored where the metal is thicker than that required to get a proper bearing by expanding, so as to form narrow seats into which the tube ends can properly expand, provided there is space available to permit a proper amount of flare of the tube end.

(g) The surface for welding shall be free of all scale, rust, oil, grease, or other foreign material.

(h) The sharp edges of the tube holes shall be taken off on both sides of the plate with a file or other tool.

HG-360.2 Attachment of Firetubes.

(a) Ends of firetubes may be expanded, expanded and flared, expanded and beaded, expanded and welded, welded, or brazed. Firetubes that require consideration as stays in HG-346 shall not be attached by expanding alone.

(b) Firetubes attached by expanding and welding or welding shall comply with HW-713. Firetubes attached by brazing shall comply with Subpart HB.

(c) Firetubes attached by expanding and flaring or expanding shall comply with the following:

(1) If the firetube ends are in contact with primary furnace gases, the tubes shall extend beyond the tubesheet a distance not less than the tube thickness or $\frac{1}{8}$ in. (3 mm), whichever is greater, but not more than $\frac{1}{4}$ in. (6 mm) or the tube thickness, whichever is greater.

(2) If the firetube ends are not in contact with primary furnace gases, the tubes shall extend beyond the tubesheet a distance not less than the tube thickness or $\frac{1}{8}$ in. (3 mm), whichever is greater, but not more than $\frac{3}{8}$ in. (10 mm) or the tube thickness, whichever is greater.

(d) Where firetubes are attached by welding, the tube holes may be drilled, flame cut, or punched. The tube holes may be punched full size provided the thickness of the tubesheet does not exceed $\frac{5}{16}$ in. (8 mm). The diameter of the tube hole in any case shall not be more than $\frac{1}{32}$ in. (0.8 mm) greater than the outside diameter of the tube.

Figure HG-350.3
Example of Tube Spacing With Pitch of Holes Varying in Every Second and Third Row

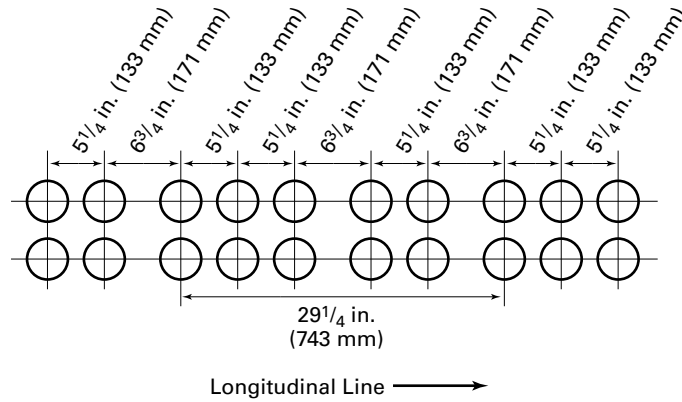
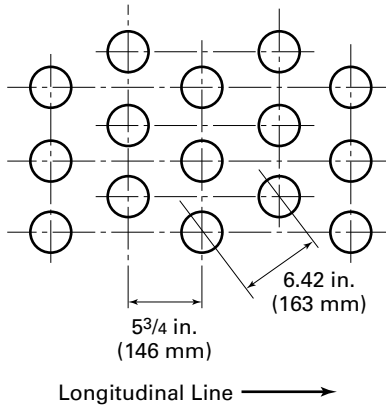

Figure HG-350.4
Example of Tube Spacing With Tube Holes on Diagonal Lines



HG-360.3 Attachment of Watertubes.

(a) Watertubes may be attached by expanding, expanding and flaring, expanding and beading, expanding and welding, welding, or brazing. Watertubes attached by expanding and welding or welding shall comply with [HW-713](#). Watertubes attached by brazing shall comply with [Subpart HB](#).

(b) The ends of all tubes that are flared shall extend beyond the tubesheet a distance not less than 1/4 in. (6 mm) nor more than 1/2 in. (13 mm).

(c) Watertubes not exceeding 2 in. (50 mm) O.D. may be attached mechanically with welded tapered ferrules. When such method of attachment is used, the tapered ferrule shall completely penetrate the head or drum and be mechanically clamped to the header or drum with bolting of no less than 3/8 in. (10 mm) diameter,

and the tubing shall not be used to support the pressure vessel.

(d) Where watertubes are attached by welding, the tube holes may be drilled, flame cut, or punched. The tube holes may be punched full size provided the thickness of the tubesheet does not exceed 5/16 in. (8 mm). The diameter of the tube hole in any case shall not be more than 1/32 in. (0.8 mm) greater than the outside diameter of the tube.

(e) Watertubes in hot water boilers may be installed into headers with the use of O-ring seals in lieu of expanding, welding, or brazing, provided the following conditions are met:

(1) The tube hole diameter shall be not more than 1/32 in. (0.8 mm) larger than the outside diameter of the tube.

(2) The tube hole shall be recessed to accommodate the O-ring.

(3) The dimensions of both the O-ring and its retaining groove shall be in accordance with the O-ring manufacturer's recommendations.

(4) The O-ring material shall be suitable for the design conditions. Material selections shall be limited to those shown in [Table HG-360](#).

Table HG-360
Permitted O-Ring Materials

Material	Temperature Limit, °F (°C)
Hydrogenated Nitrile Rubber (HNBR)	300 (150)
Ethylene Propylene Diene Rubber (EPDM)	300 (150)
TFE/Propylene Rubber (FEPM)	450 (230)
Perfluorinated Elastomer (FFKM)	480 (250)

Table HG-370
Minimum Thickness of Material for Threaded
Connections to Boilers

Size of Pipe Connection, DN in. (mm)	Minimum Thickness of Material Required, in. (mm)
Under $\frac{3}{4}$ (20)	$\frac{1}{4}$ (6)
$\frac{3}{4}$ to 1 (20 to 25), incl.	$\frac{5}{16}$ (8)
$1\frac{1}{4}$ to $2\frac{1}{2}$ (32 to 65), incl.	$\frac{7}{16}$ (11)
3 to $3\frac{1}{2}$ (80 to under 100), incl.	$\frac{5}{8}$ (16)
4 to 5 (100 to 125), incl.	$\frac{7}{8}$ (22)
6 to 8 (150 to 200), incl.	1 (25)
9 to 12 (Over 200 to 300), incl.	$1\frac{1}{4}$ (32)

(5) The O-ring shall be located or shielded in a manner determined by the boiler Manufacturer to preclude the O-ring from being exposed to temperatures higher than the maximum temperature listed in [Table HG-360](#).

(6) The headers shall be held together by stays adequately designed to carry the end loading and prevent the headers from spreading apart. The maximum allowable stress value of the stays shall not exceed that permitted in Section II, Part D, Table 6A or Table 6B.

(7) Means shall be provided to prevent the tubes from losing contact with the O-ring seal due to tube movement without loosening the stays.

(8) If the tube length exceeds 6 ft (1.8 m), the tubes shall be supported at their midlength.

HG-370 EXTERNAL PIPING CONNECTIONS

HG-370.1 Threaded Connections. Pipe connections, if threaded, shall be tapped into material having a minimum thickness as specified in [Table HG-370](#), except that when a curved surface is to be tapped the minimum thickness shall be sufficient to permit at least four full threads to be engaged.

HG-370.2 Flanged Connections.

(a) It is recommended that dimensional requirements of bolted flange connections to external piping conform to ASME B16.5, Steel Pipe Flanges and Flanged Fittings. Such flanges may be used for pressure-temperature ratings in accordance with the Standard.

(b) Steel flanges that do not conform to ASME B16.5 shall be designed in accordance with the rules in Appendix II of Section VIII, Division 1, for the design pressure and temperature conditions. The outside diameter and bolting shall conform to a standard approved by ANSI.

HG-370.3 Welded or Brazed Connections. Welded connections shall be in accordance with [HW-730](#) and [HW-731](#). Brazed connections shall be in accordance with [HB-1300](#) through [HB-1307](#).

ARTICLE 4
PRESSURE-RELIEVING DEVICES

(23)

DELETED

ARTICLE 4A

OVERPRESSURE PROTECTION

HG-400A GENERAL REQUIREMENTS

(a) This Article provides the acceptable methods and requirements for overpressure protection in heating boilers constructed to the requirements of this Section. It establishes the type, quantity, and settings of acceptable devices and the relieving capacity requirements for the applicable heating boilers. Unless otherwise specified, the pressure relief valves shall be constructed, capacity certified, and marked with the Certification Mark in accordance with Section XIII. See [Article 7](#) for installation requirements.

(b) All heating boilers within the scope of this Section shall be provided with protection against overpressure in accordance with the requirements of this Article.

(c) Section XIII, Mandatory Appendix I defines terms related to pressure relief valves. Unless these terms are otherwise defined in [Nonmandatory Appendix E](#), the definitions of Section XIII shall apply to this Article.

(23) HG-401A RESPONSIBILITY

(a) It is the Manufacturer's responsibility to determine the minimum required relief rate and maximum allowable working pressure (MAWP) that meet the requirements of this Article.

(b) The installer or Manufacturer is responsible for sizing and selecting the pressure relief valve or valves that meet the requirements of this Article.

(c) Pressure relief valves shall be installed by either the installer or the Manufacturer before a boiler is put in operation.

HG-402A PRESSURE RELIEF VALVE REQUIREMENTS

HG-402A.1 Pressure Relief Valve Requirements for Steam Boilers.

(a) Each steam boiler shall have one or more pressure relief valves marked either with the Certification Mark and HV Designator in accordance with Section XIII or with the Certification Mark and V Designator in accordance with Section I.

(b) The pressure relief valve shall be of the spring-loaded safety valve type adjusted and sealed to discharge at a pressure not to exceed 15 psi (100 kPa). The set pressure tolerance shall not exceed ± 2 psi (± 15 kPa).

(c) The pressure relief valve capacity for each steam boiler shall be such that with the fuel-burning equipment installed and operated at maximum capacity, the pressure cannot rise more than 5 psi (35 kPa) above the MAWP.

(d) Pressure relief valves shall have a controlled blow-down of 2 psi to 4 psi (15 kPa to 30 kPa).

(e) No pressure relief valve for a steam boiler shall be smaller than NPS $\frac{1}{2}$ (DN 15) or larger than NPS 4 (DN 100). The inlet opening shall have an inside diameter equal to or greater than the seat diameter.

(f) Pressure relief valves shall be arranged so that they cannot be reset to relieve at a higher pressure than the MAWP of the boiler.

(g) Body drain connections shall not be plugged during or after field installation.

(h) The minimum relieving capacity of the pressure relief valve or valves shall be governed by the capacity marking on the boiler required by [HG-530](#).

(i) The minimum valve capacity in pounds per hour shall be determined by dividing the maximum Btu/hr (kW) output at the boiler nozzle, obtained by the firing of any fuel for which the unit is installed, by 1,000 (0.646). In every case, the requirement of (e) shall be met.

(j) When operating conditions are changed, or additional boiler heating surface is installed, the valve capacity shall be increased, if necessary, to meet the new conditions and be in accordance with (c). The additional valves required on account of changed conditions may be installed on the outlet piping provided there is no intervening valve.

HG-402A.2 Pressure Relief Valve Requirements for Hot Water Heating and Supply Boilers. (23)

(a) Each hot water heating or supply boiler shall have at least one pressure relief valve. Each pressure relief valve shall be marked either with the Certification Mark and HV Designator in accordance with Section XIII or with the Certification Mark and V Designator in accordance with Section I.

(b) Each pressure relief valve shall be of the spring-loaded safety relief valve type and set to relieve at or below the MAWP of the boiler.

(c) Pressure relief valve capacity for each boiler with a single pressure relief valve shall be such that, with the fuel burning equipment installed and operated at maximum capacity, the pressure cannot rise more than 10% above the MAWP. When more than one pressure relief valve is used, the overpressure shall be limited to 10% above the set pressure of the highest set valve.

(d) No pressure relief valve shall be smaller than NPS $\frac{3}{4}$ (DN 20) nor larger than NPS 4 (DN 100) except that boilers having a heat input not greater than 15,000 Btu/hr (4.4 kW) may be equipped with a capacity-certified pressure relief valve of NPS $\frac{1}{2}$ (DN 15).

(e) The required steam-relieving capacity, in pounds per hour (kilograms per hour), of the pressure-relieving device or devices on a boiler shall be determined by dividing the maximum output in Btu/hr (kW) at the boiler nozzle, obtained by the firing of any fuel for which the unit is installed, by 1,000 (0.646). In every case, the requirements of (c) shall be met.

(f) When operating conditions are changed, or additional boiler heating surface is installed, the valve capacity shall be increased, if necessary, to meet the new conditions and shall be in accordance with (c). The additional valves required due to changed conditions may be installed on the outlet piping provided there is no intervening valve.

(g) Hot water heating or supply boilers limited to a water temperature not in excess of 210°F (99°C) may have, in lieu of the valve(s) specified in (a), one or more temperature and pressure relief valves of the spring-loaded type marked with the Certification Mark and HV Designator in accordance with Section XIII. The temperature and pressure relief valve shall be set to relieve at or below the MAWP of the boiler.

HG-402A.3 Pressure Relief Valves for Tanks and Heat Exchangers.

(a) *Steam to Hot Water Supply.*

(1) When a hot water supply is heated indirectly by steam in a coil or pipe within the service limitations set forth in **HG-101**, the pressure of the steam shall not exceed the safe working pressure of the hot water tank. Each tank shall have a pressure relief valve marked either with the Certification Mark and HV Designator in accordance with Section XIII or with the Certification Mark and V Designator in accordance with Section I.

(2) The pressure relief valve shall be of the spring-loaded safety relief valve type and set to relieve at or below the MAWP of the tank. The set pressure tolerances shall not exceed 3 psi (20 kPa) for pressures up to and including 60 psig (400 kPa) and $\pm 5\%$ for set pressures above 60 psig (400 kPa).

(3) The pressure relief valves shall be of sufficient rated capacity to prevent the heat exchanger pressure from rising more than 10% above the maximum allowable working pressure of the vessel.

(4) The pressure relief valve shall be at least NPS 1 (DN 25).

(b) *High-Temperature Water to Water Heat Exchanger.*⁷

(1) When high-temperature water is circulated through the coils or tubes of a heat exchanger to warm water for space heating or hot water supply, within the service limitations set forth in **HG-101**, the heat exchanger shall be equipped with one or more pressure relief valves marked either with the Certification Mark and HV Designator in accordance with Section XIII or with the Certification Mark and V Designator in accordance with Section I.

(2) The pressure relief valve shall be of the spring-loaded safety relief valve type and set to relieve at or below the MAWP of the heat exchanger. The set pressure tolerances shall not exceed 3 psi (20 kPa) for pressures up to and including 60 psig (400 kPa) and $\pm 5\%$ for set pressures above 60 psig (400 kPa).

(3) The pressure relief valves shall be of sufficient rated capacity to prevent the heat exchanger pressure from rising more than 10% above the maximum allowable working pressure of the vessel.

(4) No pressure relief valve shall be smaller than NPS $\frac{3}{4}$ (DN 20) nor larger than NPS 4 (DN 100).

(c) *High-Temperature Water to Steam Heat Exchanger.*⁷

(1) When high-temperature water is circulated through the coils or tubes of a heat exchanger to generate low pressure steam, within the service limitations set forth in **HG-101**, the heat exchanger shall be equipped with one or more pressure relief valves marked either with the Certification Mark and HV Designator in accordance with Section XIII or with the Certification Mark and V Designator in accordance with Section I.

(2) The pressure relief valve shall be of the spring-loaded safety valve type and set to relieve at a pressure not to exceed 15 psi (100 kPa). The set pressure tolerance shall not exceed ± 2 psi (± 15 kPa).

(3) Pressure relief valves shall have a controlled blowdown of 2 psi to 4 psi (15 kPa to 30 kPa).

(4) No pressure relief valve for a steam boiler shall be smaller than NPS $\frac{1}{2}$ (DN 15) nor larger than NPS 4 (DN 100).

(5) For heat exchangers requiring steam pressures greater than 15 psi (100 kPa), refer to Section I or Section VIII, Division 1.

HG-402A.4 Pressure Relief Valves for Potable Water Heaters. See [HLW-800](#).

HG-403A HEATING SURFACE

The heating surface, as part of a circulating system in contact on one side with water or wet steam being heated and on the other side with gas or refractory being cooled, shall be measured on the side receiving heat.

The heating surface shall be computed as follows:

(a) The boiler heating surface and other equivalent surface outside the furnace shall be measured circumferentially plus any extended surface.

(b) The waterwall heating surface and other equivalent surface within the furnace shall be measured as the projected tube area (diameter \times length) plus any extended surface on the furnace side. In computing the heating surface for this purpose, only the tubes, fireboxes, shells, tubesheets, and the projected area of headers need be considered, except that for vertical firetube steam boilers, only that portion of the tube surface up to the middle of the gage glass shall be calculated.

(c) The total heating surface is the sum of the boiler and waterwall heating surfaces.

ARTICLE 5

TESTS, INSPECTION, AND MARKING

HG-500 PROOF TESTS TO ESTABLISH DESIGN PRESSURE

HG-501 General

(a) The design pressure for pressure parts of boilers for which the strength cannot be computed with a satisfactory assurance of accuracy shall be established in accordance with the requirements of this paragraph, using one of the test procedures applicable to the type of loading and to the material used in its construction.

(b) The tests in these paragraphs may be used only for the purpose of establishing the design pressure of those elements or component parts for which the thickness cannot be determined by means of the design rules given in the Code. The design pressure of all other elements or component parts shall not be greater than that determined by means of the applicable design rules.

HG-501.1 Types of Tests. Provision is made for two types of tests for determining the internal design pressure:

(a) tests based on yielding of the part to be tested; these tests are limited to materials with a ratio of minimum specified yield to minimum specified ultimate strength of 0.625 or less. If a proof-tested part shows no evidence of permanent yielding per [HG-502.1](#) and [HG-502.2](#), it may be marked with the Certification Mark.

(b) tests based on bursting of the part. The Certification Mark shall not be applied on the part proof tested under the burst-test provisions.

HG-501.2 Retests. A retest shall be allowed on a duplicate pressure part if errors or irregularities are obvious in the test results.

HG-501.3 Precautions. Safety of testing personnel should be given serious consideration when conducting proof tests, and particular care should be taken during the conducting of bursting tests per [HG-502.3](#).

HG-501.4 Pressure Application.

(a) *Previously Applied.* The pressure parts for which the design pressure is to be established shall not previously have been subjected to a pressure greater than $1\frac{1}{2}$ times the desired or anticipated design pressure.

(b) *Application.* In the procedures given in [HG-502.1](#) for the strain measurement test and [HG-502.2](#) for the displacement measurement test, the hydrostatic pressure in the pressure part shall be increased gradually until approximately one-half the anticipated design pressure is reached. Thereafter, the test pressure shall be increased in steps of approximately one-tenth or less of the anticipated design pressure until the pressure required by the test procedure is reached. The pressure shall be held stationary at the end of each increment for a sufficient time to allow the observations required by the test procedure to be made and shall be released to zero to permit determination of any permanent strain or displacement after any pressure increment that indicates an increase in strain or displacement over the previous equal pressure increment.

HG-501.5 Critical Areas. As a check that the measurements are being taken on the most critical areas, the Inspector may require a lime wash or other brittle coating to be applied on all areas of probable high stress concentrations in the test procedures given in [HG-502.1](#) and [HG-502.2](#). The surfaces shall be suitably clean before the coating is applied in order to obtain satisfactory adhesion. The technique shall be suited to the coating material.

NOTE: Strains should be measured as they apply to membrane stresses. In regard to bending stresses it is recognized that high localized and secondary stresses may exist in pressure parts designed and fabricated in accordance with these rules. Insofar as practical, design rules for details have been written to hold such stresses at a safe level consistent with experience.

HG-501.6 Yield Strength and Tensile Strength. For proof tests based on yielding, [HG-502.1](#) and [HG-502.2](#), the yield strength (or yield point for those materials that exhibit that type of yield behavior indicated by a "sharp-knead" portion of the stress-strain diagram) of the material in the part tested, shall be determined in accordance with the method prescribed in the applicable material specification and as described in ASTM E8, Tension Testing of Metallic Materials. For proof tests based on bursting, [HG-502.3](#), the tensile strength instead of the yield strength of the material in the part tested shall be similarly determined.

(a) Yield or tensile strength so determined shall be the average from three or four specimens cut from the part tested after the test is completed. The specimens shall be cut from a location where the stress during the test has not exceeded the yield strength. The specimens shall not be oxygen cut because this might affect the strength of the material. If yield or tensile strength is not determined by test specimens from the pressure part tested, alternative methods are given in [HG-502.1](#), [HG-502.2](#), and [HG-502.3](#) for evaluation of proof test results to establish the design pressure.

(b) When excess stock from the same piece of wrought material is available the test specimens may be cut from this excess stock. The specimens shall not be removed by flame cutting or any other method involving sufficient heat to affect the properties of the specimen.

(c) For cast pressure parts, cast test bars may be used in lieu of the specimens referenced above. If used, cast test bars shall be produced, machined, and tested in accordance with the requirements of Section II. Cast test bars shall be poured from the same ladle of material, under the same sand conditions, that the cast pressure part subjected to bursting is poured from and shall receive the same thermal treatment as the cast pressure part subjected to bursting.

HG-502 Procedure

HG-502.1 Strain Measurement Test.

(a) Subject to limitations of [HG-501.1\(a\)](#), this procedure may be used for pressure parts under internal pressure, constructed of any material permitted to be used under the rules of Section IV. Strains shall be measured in the direction of the maximum stress at the most highly stressed parts (see [HG-501.5](#)) by means of strain gages of any type capable of indicating strains to 0.00005 in./in. (0.005%). Pressure shall be applied as provided in [HG-501.4\(b\)](#).

(b) After each increment of pressure has been applied, readings of the strain gages and the hydrostatic pressure shall be taken and recorded. The pressure shall be released and any permanent strain at each gage shall be determined after any pressure increment that indicates an increase in strain for this increment over the previous equal pressure increment. Only one application of each increment of pressure is required.

(c) Two curves of strain against test pressure shall be plotted for each gage line as the test progresses, one showing the strain under pressure and one showing the permanent strain when the pressure is removed. The test may be discontinued when the test pressure reaches the value H that will, by the formula, justify the desired working pressure, but shall not exceed the pressure at which the plotted points for the most

highly strained gage line reaches the value given below for the material used:

(1) 0.2% permanent strain for carbon, low alloy, and high alloy steels

(2) 0.5% strain under pressure for copper-base alloys

(d) The design pressure P for parts tested under this paragraph shall be computed by one of the following equations:

(1) if the average yield strength is determined by [HG-501.6](#),

$$P = 0.5H \frac{Y_s}{Y_a}$$

(2) if the actual average yield strength is not determined by test specimens,

$$P = 0.4H$$

where

H = hydrostatic test pressure at which the test was stopped in accordance with [\(c\)](#)

Y_a = actual average yield strength from test specimens

Y_s = specified minimum yield strength

HG-502.2 Displacement Measurement Test. (23)

(a) Subject to the limitations of [HG-501.1\(a\)](#), this procedure may be used only for pressure parts under internal pressure, constructed of materials having a definitely determinable yield point. Displacement shall be measured at the most highly stressed parts (see [HG-501.5](#)) by means of measuring devices of any type capable of measuring to 1 mil (0.025 mm). This displacement may be measured between two diametrically opposed reference points in a symmetrical structure, or between a reference point and a fixed base point. Pressure shall be applied as provided in [HG-501.4\(b\)](#).

(b) After each increment of pressure has been applied, readings of the displacement and the hydrostatic pressure shall be taken and recorded. The pressure shall be released and any permanent displacement shall be determined after any pressure increment that indicates an increase in measured displacement for this increment over the previous equal pressure increment. Only one application of each increment is required. Care must be taken to insure that the readings represent only displacements of the parts on which measurements are being made and do not include any slip of the measuring devices or any movement of the fixed base points or of the pressure part as a whole.

(c) Two curves of displacement against test pressure shall be plotted for each reference point as the test progresses, one showing the displacement under

pressure, and one showing the permanent displacement when the pressure is removed. The application of pressure shall be stopped when it is evident that the curve through the points representing displacement under pressure has deviated from a straight line.

(d) The pressure coincident with the proportional limit of the material shall be determined by noting the pressure at which the curve representing displacement under pressure deviates from a straight line. The pressure at the proportional limit may be checked from the curve of permanent displacement by locating the point where the permanent displacement begins to increase regularly with further increases in pressure. Permanent deformation at the beginning of the curve that results from the equalization of stresses and irregularities in the material may be disregarded.

The design pressure P at test temperature for parts tested under this paragraph shall be computed by one of the following equations.

(1) If the average yield strength is determined by HG-501.6,

$$P = 0.5H \frac{Y_s}{Y_a}$$

(2) In order to eliminate the necessity of cutting tensile specimens and determining the actual yield strength of the material under test, one of the following equations may be used to determine the design pressure:

(-a) for carbon steel, meeting an acceptable Code specification, with a specified minimum tensile strength of not over 70,000 psi (480 MPa)

(U.S. Customary Units)

$$P = 0.5H \left(\frac{S}{S + 5,000} \right) \quad (2a)$$

(SI Units)

$$P = 0.5H \left(\frac{S}{S + 34,000} \right) \quad (2a)$$

(-b) for any acceptable material listed in Section II, Part D, Table 6A, Table 6B, Table 6C, or Table 6D

$$P = 0.4H \quad (2b)$$

where

H = hydrostatic test pressure coincident with the proportional limit of the weakest element of the component part tested

S = specified minimum tensile strength

Y_a = actual average yield strength from test specimens

Y_s = specified minimum yield strength

(e) When eq. (2a) of (d)(2)(-a) or eq. (2b) of (d)(2)(-b) is used, the material in the pressure part shall have had no appreciable cold working or other treatment that would tend to raise the yield strength above the normal.

HG-502.3 Bursting Tests.

(a) This procedure may be used for pressure parts under internal pressure when constructed of any material permitted to be used under the rules of Section IV. The design pressure of any component part proof tested by this method shall be established by a hydrostatic test to failure by rupture of a full-size sample of such pressure part. As an alternative, the hydrostatic test may be stopped when the test pressure reaches a value that will, by the formula in (b) below, justify the design pressure.

(b) The design pressure P , psi, for pressure parts tested under this paragraph shall be computed by the following formula:

$$P = \frac{P_B}{5} \times \frac{S}{S_a \text{ or } S_m}$$

where

P_B = bursting test pressure

S = specified minimum tensile strength

S_a = average actual tensile strength of test specimens or cast test bars

S_m = maximum tensile strength of range of specification

HG-502.4 Brittle Coating Test Procedure. (23)

(a) Subject to the limitations of HG-501.1(a), this procedure may be used only for boiler and boiler parts under internal pressure, constructed of materials having a definitely determinable yield point. The component parts that require proof testing shall be coated with a lime wash or other brittle coating in accordance with HG-501.5. Pressure shall be applied in accordance with HG-501.4. The parts being proof tested shall be examined between pressure increments for signs of yielding as evidenced by flaking of the brittle coating, or by the appearance of strain lines. The application of pressure shall be stopped at the first sign of yielding, or if desired, at some lower pressure.

(b) The design pressure P for parts tested under this paragraph shall be computed by one of the following equations:

(1) if the average yield strength is determined in accordance with HG-501.6,

$$P = 0.5H \frac{Y_s}{Y_a}$$

(2) to eliminate the necessity of cutting tensile specimens and determining the actual yield strength of the material under test, one of the following equations may be used to determine the design pressure:

(-a) for carbon steel meeting an acceptable Code specification, with a specified minimum tensile strength of not over 70,000 psi (480 MPa),

(U.S. Customary Units)

$$P = 0.5H \left(\frac{S}{S + 5,000} \right) \quad (2a)$$

(SI Units)

$$P = 0.5H \left(\frac{S}{S + 34\,500} \right) \quad (2a)$$

(-b) for any acceptable material listed in Section II, Part D, Table 6A, Table 6B, Table 6C, or Table 6D

$$P = 0.4H \quad (2b)$$

where

H = hydrostatic test pressure at which the test was stopped

S = specified minimum tensile strength

Y_a = actual average yield strength from test specimens

Y_s = specified minimum yield strength

(c) When eq. (2a) of (b)(2)(-a) or eq. (2b) of (b)(2)(-b) is used, the material in the pressure part shall have had no appreciable cold working or other treatment that would tend to raise the yield strength above the normal.

HG-503 Tests of Parts Subject to Collapse

Parts of the boiler normally subject to collapse for which specified rules are not provided in this Section shall withstand without excessive deformation a hydrostatic test of not less than three times the desired design pressure.

HG-504 Tests of Duplicate Parts

When the design pressure of a pressure part has been established by a proof test, duplicate parts of the same materials, design, and construction need not be proof tested but shall be given the standard hydrostatic test at $1\frac{1}{2}$ times the maximum allowable working pressure. The dimensions and minimum thickness of the structure to be tested should not vary materially from those actually used. A geometrically similar part may be qualified by a series of tests covering the complete size range of the pressure part.

HG-505 Test Gages

(a) An indicating gage shall be connected directly to the pressure part. Intermediate pipe and fittings may be used provided there are no intervening valves. If the indicating gage is not readily visible to the operator controlling the pressure applied, an additional indicating gage shall be provided where it will be visible to the operator throughout the duration of the test. For large pressure parts, it is recommended that a recording gage be used in addition to indicating gages.

(b) Dial indicating pressure gages used in testing shall be graduated over a range of about double the intended maximum test pressure, but in no case shall the range be less than $1\frac{1}{2}$ nor more than 4 times that pressure. Digital reading pressure gages having a wider range of pressure may be used provided the readings give the same or greater degree of accuracy as obtained with dial pressure gages.

(c) All gages used in proof testing shall be calibrated against a standard deadweight tester or a calibrated master gage before the proof test is begun. Gages shall be recalibrated at any time that there is reason to believe they are in error.

HG-506 Inspection of Proof Tests

Tests to establish the design pressure of pressure parts shall be witnessed and accepted by an Authorized Inspector.

HG-510 Hydrostatic Tests

(a) Cast iron boilers shall be tested in accordance with HC-410.

(b) For boilers with integrally finned tubes and a design pressure of 160 psi (1.1 MPa), both the pneumatic test required in HF-204.1(e) and the hydrostatic test of (c) may be alternatively met by a hydrostatic test on the boiler under the following conditions:

(1) A hydrostatic test pressure of at least 240 psi (1.9 MPa) is applied to the tubes and boiler.

(2) A hold time of 5 min is maintained on the boiler at the required internal test pressure.

(3) The test pressure may then be reduced to maximum allowable working pressure for inspection.

(4) The tubes must be readily visible for inspection while under pressure.

(c) All other boilers shall be subjected to a hydrostatic test pressure that is not less than the greater of 60 psi (0.400 MPa) or $1\frac{1}{2}$ times the design pressure, except if a boiler made of material in Part HF has its maximum allowable working pressure limited by a Part HC cast iron part the test pressure may be extended to $2\frac{1}{2}$ times the design pressure of the cast iron part or $1\frac{1}{2}$ times the design pressure of the next limiting part, whichever is less.

Close visual inspection is not required during this stage. The hydrostatic test pressure may then be reduced to the maximum allowable working pressure to be marked on the boiler and maintained at this pressure while close visual inspection for leakage is made of all joints and connections. In making hydrostatic pressure tests, the pressure shall be under such control that the test pressure established shall not be exceeded by more than 10 psi (70 kPa). The visual inspection of joints and connections that are hidden by assembly may be waived during the hydrostatic test provided the following conditions are met:

(1) A suitable pressure test, as agreed upon by the Manufacturer and the Authorized Inspector, is applied to the hidden joints.

(2) The hidden joints are given a visual examination by the Authorized Inspector for workmanship prior to final assembly.

(23) HG-511 Pneumatic Tests

Pneumatic testing may be substituted for the hydrostatic test required in [HG-510](#) provided the following requirements are met:

(a) The substitution of pneumatic testing shall be by agreement between the Manufacturer and Authorized Inspector.

(b) Maximum material thickness of any component part shall not exceed $\frac{1}{2}$ in. (12.7 mm). No components of the heating boiler that will be subject to pneumatic testing may be constructed of cast iron.

(c) Nitrogen or clean, dry, oil-free air shall be used.

(d) The boiler shall be visually inspected for evidence of damage before pressurization.

(e) The boiler should be tested in such a manner as to ensure personnel safety from a release of the total internal energy of the vessel. Section IV does not address all possible safety considerations associated with use of the pneumatic test. It is the responsibility of the Manufacturer to establish appropriate safety and health practices and to determine the applicability of any regulatory requirements or limitations before the application of the pneumatic test.

(f) The required test pressure shall be greater of 38 psi (262 kPa) or 1.1 times the MAWP.

(g) Overpressure relief protection shall be provided. The set pressure of a pressure relief valve should not be more than the greater of

(1) the test pressure plus 10 psi (70 kPa)

(2) 110% of the test pressure

(h) A minimum hold time of 5 min shall be maintained on the boiler at the required test pressure.

(i) The Manufacturer's Data Report Forms shall state in the Remarks section, "Pneumatic test performed in lieu of standard hydrostatic test as prescribed in [HG-510](#)."

(j) The pneumatic test method shall be immersed visual inspection.

(1) The boiler shall be externally cleaned to prevent air bubble adherence while being tested to prevent leaks from being masked.

(2) The uppermost portion of the boiler, as oriented in the test tank, shall be a minimum of 6 in. (150 mm) below the surface of the water, and the water shall have a minimum temperature of 60°F (16°C).

(3) Before the holding period, the immersed boiler shall be rotated a minimum of 180 deg around a lateral axis to release any trapped air.

(4) After the holding period, the pressure may be reduced to the MAWP, but not less than 38 psi (262 kPa), and maintained at this pressure while a thorough visual inspection for leakage is made with the boiler submerged in water.

(5) After the holding period, and during the visual inspection, the immersed boiler shall be rotated a minimum of 180 deg around a lateral axis to permit easy visual detection of any leakage.

(6) Any evidence of air leaking from the vessel indicates failure of the pneumatic pressure test.

HG-512 Pressure Relief Valve Accumulation Tests

If the pressure relief valve capacity cannot be computed or if it is desirable to prove the computations, it may be checked in any one of the following ways and, if found insufficient, additional capacity shall be provided

(a) by making an accumulation test, that is, by shutting off all discharge outlets from the boiler and forcing the fires to the maximum, the pressure relief valve equipment shall be sufficient to prevent an excess pressure beyond that specified in [HG-402A.1\(j\)](#) and [HG-402A.2\(g\)](#).

(b) by measuring the maximum amount of fuel that can be burned, and computing the corresponding evaporative capacity upon the basis of the heating value of the fuel. (See [B-100](#), [B-101](#), and [B-102](#).)

HG-515 Inspection Tests and Certification of Boilers

HG-515.1 General. The inspection and testing of boilers to be marked with the Certification Mark with H designator shall conform to the general requirements for inspection and testing in the following paragraphs and, in addition, to the specific requirements for inspection and tests given in [Parts HF](#) and [HC](#).

HG-515.2 Manufacturer's Responsibility. (23) The Manufacturer has the responsibility of providing the Inspector with all specified information and of assuring that the quality control, the detailed examination, and the tests required by this Section are performed at the stages of construction necessary to permit them to be meaningful (see [F-202.5](#)). These responsibilities shall include, but not

be limited to, providing or making available for review the following:

(a) the Certificate of Authorization from the ASME Boiler and Pressure Vessel Committee authorizing the Manufacturer to fabricate the type of boiler being constructed (see [HG-540](#))

(b) the drawings and design calculations for the boiler or part (see [Part HG, Article 3](#); [Part HF, Article 3](#); [Subpart HW, Article 7](#); [Subpart HB, Article 13](#); and [Part HC, Article 3](#))

(c) identification for all materials used in the fabrication of the boiler or part (see [Part HG, Article 2](#); [Subpart HW, Article 5](#); [Subpart HB, Article 11](#); and [Part HC, Article 2](#))

(d) any Manufacturer's Partial Data Reports when required (see [HG-531](#))

(e) access for the Inspector to those parts of the plant concerned with the supply or fabrication of materials for the boiler; keeping the Inspector informed of the progress of the work so that the required inspections can be performed in the proper sequence (see [HW-900](#), [HB-1500](#), and [F-202.5](#))

(f) evidence of examination of all material before and during fabrication to make certain it has the required thickness, has no unacceptable imperfections, is one of the acceptable materials permitted by this Section, and that traceability to the material identification has been maintained (see [HG-201](#), [HC-502.5](#), [F-202.4](#), and [HF-210](#))

(g) concurrence of the Inspector for correction of nonconformities in accordance with the Quality Control System (see [F-202.6](#))

(h) evidence of qualification of the welding and/or brazing procedures before they are used in fabrication (see [HW-610](#), [HB-1001](#), [HB-1202](#), and [F-202.7](#))

(i) evidence of qualification of all welders, welding operators, or brazers before the welders, welding operators, or brazers are used in production work, except that performance qualification by radiography, in conformance with Section IX, QW-304 for welders or QW-305 for welding operators, may be performed within the first 3 ft (1 m) of the first production weld (see [HW-401](#), [HW-610](#), [HB-1001](#), [HB-1202](#), and [F-202.7](#))

(j) records of examination of parts prior to joining to make certain that they have been properly fitted for welding or brazing and that the surfaces to be joined have been cleaned and the alignment tolerances are maintained (see [Subpart HW, Article 8](#); [Subpart HB, Article 14](#); and [F-202.7](#))

(k) records of examination of parts as fabrication progresses for material marking, that surface defects are not evident, and that dimensional geometrics are maintained (see [HG-515.1](#); [HF-210](#); [Subpart HW, Article 8](#); [HC-200](#); [HC-502.5](#); and [HC-502.6](#))

(l) subjecting the boiler to the required hydrostatic test (see [HG-510](#))

(m) affixing the required marking and/or nameplate to the boiler and making certain it is affixed to the proper boiler (see [HG-530](#))

(n) completing the required Manufacturer's Data Report Form and having it certified by the Inspector (see [HG-520](#)) for boilers and boiler parts constructed of wrought materials

(o) completing the required Manufacturer's Master Data Report Form and having it certified by the Certified Individual meeting the current requirements of ASME QAI-1 (see [HC-502.12](#) or [HA-502.12](#); for boilers constructed of cast iron or cast aluminum, see [HC-403](#) or [HA-404](#))

(p) retention of Manufacturer's Data Reports [see [HG-520.1\(b\)](#), [HC-403](#), [HC-502.10](#), [HA-404](#), and [HA-502.10](#)]

(q) the Certificates of Conformance for cast iron boiler sections (see [HC-520](#)) and cast aluminum boiler sections (see [HA-504](#))

HG-515.3 Inspection by an Authorized Inspector. (23)

(a) Except for cast iron boilers, cast aluminum boilers, or pressure relief valves, the inspection required by this Section shall be by an Inspector employed by an ASME Accredited Authorized Inspection Agency. These inspectors shall have been qualified in accordance with ASME QAI-1.

(b) The Inspector shall make all inspections specifically required of him plus such other inspections as he believes are necessary to enable him to certify that all boilers and boiler parts constructed of wrought material that he authorizes to be marked with the Certification Mark have been designed and constructed in accordance with the requirements of this Code Section. The required inspections and verifications shall include, but not be limited to, the following:

(1) checking to see that the Manufacturer has a valid Certificate of Authorization (see [HG-540](#)) and is working to the quality control system accepted by the Society (see [HG-540.1](#))

(2) checking to see that the design calculations, drawings, specifications, procedures, records, and test results are available (see [HG-300](#), [HG-200](#), [HG-500](#), [HF-200](#), and [HW-700](#))

(3) checking to see that material used in the construction of the boiler and parts complies with the requirements (see [HG-200](#), [HF-200](#), and [HB-1100](#))

(4) checking to see that all welding procedures have been qualified (see [HW-910](#))

(5) checking to see that all welders and welding operators have been qualified (see [HW-911](#))

(6) checking to see that all brazing procedures have been qualified (see [HB-1501](#))

(7) checking to see that all brazer and brazer operators have been qualified (see [HB-1502](#))

(8) checking to see that the proper joint factor is used for brazed joints that can only be inspected from one side (blind joint) (see [HB-1503](#))

(9) checking to see that material imperfections repaired by welding were acceptably repaired (see [HW-830](#) and [HB-1402](#))

(10) visual inspection of boiler parts to confirm that the material identification numbers have been properly transferred (see [HF-210](#))

(11) witnessing of proof tests conducted to establish the maximum allowable working pressure of boilers (see [HG-500](#))

(12) inspecting each boiler and water heater during construction and after completion (see [HG-515.3](#))

(13) performing internal and external inspections and witnessing hydrostatic tests (see [HG-510](#))

(14) verifying that the marking and/or nameplate is correct and has been applied and/or attached to the proper boiler (see [HG-530](#) through [HG-533](#))

(15) signing the certificate of inspection on the Manufacturer's Data Report when the boiler or part is complete and in compliance with all the provisions of this Section (see [HG-532.3](#), [HG-533.6](#), and [HG-520.2](#))

HG-515.4 Duty of Authorized Inspector.

(a) Each boiler shall be inspected during construction and after completion and, at the option of the Authorized Inspector, at such other stages of the work as he may designate. For specific requirements, see the applicable parts of this Section. Each Manufacturer or assembler is required to arrange for the services of Authorized Inspectors (see [HG-515.2](#)) to perform such inspections on all of this work within the scope of this Section, whether performed in the shop or in the field.

(b) When mass production of boilers or HLW-marked vessels makes it impracticable for the Inspector to personally perform each of his required duties, the Manufacturer, in collaboration with the Inspector, shall prepare an inspection and quality control procedure setting forth, in complete detail, the method by which the requirements of this Section shall be maintained (for summaries of the responsibilities of the Manufacturer and the duties of the Inspector see [HG-515.2](#) and [HG-515.3](#) for boilers or [HLW-600.2](#) and [HLW-600.3](#) for HLW-marked vessels). This procedure shall be included in the Manufacturer's written Quality Control System. It shall be developed, accepted, and implemented in accordance with [Mandatory Appendix 7](#).

(23) HG-520 Manufacturer's Data Reports

HG-520.1 Manufacturer's Master Data Report.

Each manufacturer of heating boilers of wrought materials to which the Certification Mark with H designator is to be

applied shall complete a Manufacturer's Data Report Form for each boiler he produces, except that an individual Manufacturer's Data Report Form may be used to include the serial numbers in uninterrupted sequence of identical boilers completed, inspected, and marked in a continuous 8-hr period. [Form H-2](#) or [Form H-3](#) shall be used.

A Manufacturer's Master Data Report Form shall be created when a completed boiler or an uninterrupted sequence of identical boilers completed, inspected, and marked in a continuous 8-hr period as defined in [HG-530.1](#) has more than one associated Manufacturer's Data Report. The Manufacturer's Master Data Report Form shall be used to summarize all applicable Manufacturer's Data Reports, Partial Data Reports, and Supplementary Sheets for the items comprising the completed boiler or completed sequence of boilers as defined in [HG-530.1](#). The "YES" box next to "Manufacturer's Master Data Report" shall be checked to create the Manufacturer's Master Data Report Form. [Form H-2](#) or [Form H-3](#) shall be used.

(a) The boiler Manufacturer shall have the responsibility of furnishing a copy of the Manufacturer's Master Data Report or Manufacturer's Data Report at the place of installation to the inspection agency, the purchaser, and the state, municipal, or provincial authority.

(b) The Manufacturer shall either keep a copy of the Manufacturer's Master Data Report or Manufacturer's Data Report on file for at least 5 years, or the boiler may be registered and the original Manufacturer's Master Data Report or Manufacturer's Data Report filed with the National Board of Boiler and Pressure Vessel Inspectors, 1055 Crupper Avenue, Columbus, Ohio 43229.

HG-520.2 Manufacturer's Partial Data Reports.

(a) Manufacturer's Partial Data Reports for those parts of a boiler requiring inspection under this Code, which are furnished by other than the shop of the manufacturer responsible for the completed boiler, shall be completed by the parts manufacturer and shall be forwarded in duplicate to the manufacturer of the finished boiler.

(b) Manufacturer's Partial Data Report Forms, [Form H-4](#), shall be completed for all parts that require inspection under this Code that are fabricated by a manufacturer other than the manufacturer of the completed boiler. These Manufacturer's Partial Data Reports, together with his own inspection, shall be the final Authorized Inspector's authority to witness the application of the Certification Mark to the completed boiler.

(c) Manufacturers with multiple locations, each with its own Certificate of Authorization, may transfer parts from one of their locations to another without Manufacturer's Partial Data Reports, provided the Quality Control System

Figure HG-530.1
Official Certification Mark to Denote the American
Society of Mechanical Engineers' Standard

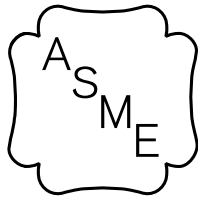

describes the method of identification, transfer, and receipt of the parts.

HG-520.3 Manufacturer's Data Report Supplementary Sheet. The Manufacturer's Data Report Supplementary Sheet, [Form H-6](#), shall be used to record additional data where space was insufficient on a Manufacturer's Data Report Form. This Manufacturer's Data Report Supplementary Sheet shall be attached to the Manufacturer's Data Report Form where used. If [Form H-6](#) is used in conjunction with [Form H-5](#) or [H-5A](#), the Authorized Inspector's certification is not applicable.

HG-520.4 Multipage Manufacturer's Data Reports. Requirements for completing multiple pages of Manufacturer's Data Report Forms are shown in [Mandatory Appendix 4](#).

HG-530 Marking of Boilers

(23) **HG-530.1 Marking Requirements for Boilers (and Economizers Built to [Mandatory Appendix 10](#)) Other Than Those Constructed Primarily of Cast Iron or Cast Aluminum (See [HG-530.2](#)).**

(a) All boilers to which the Certification Mark is to be applied shall be built according to the rules of this Section by a manufacturer who is in possession of a Certification Mark and a valid Certificate of Authorization. Each boiler shall be marked with the Certification Mark shown in [Figure HG-530.1](#) with the H designator and with the following data except as permitted in (f) below:

- (1) the boiler manufacturer's name, preceded by the words "Certified by"
- (2) maximum allowable working pressure
- (3) pressure relief valve capacity (minimum), as determined according to [HG-402A.1\(i\)](#) and [HG-402A.2\(f\)](#)
- (4) heating surface, as determined according to [HG-403A](#) (or power input for electric boilers)
- (5) manufacturer's serial number
- (6) year built
- (7) maximum water temperature

(8) for economizers, heat absorption in Btu/hr (kW)

NOTE: The year built may be incorporated into the serial number as a prefix consisting of the last two digits of the year.

(b) The information listed in (a), including the Certification Mark, shall be applied by stamping, etching, engraving, dot peening, laser annealing, or another process that leaves a permanent, legible mark. No coating that obscures the marking shall be allowed. For processes other than direct stamping, the following additional requirements apply:

(1) The process controls shall be described in the Quality Control System and shall be acceptable to the Authorized Inspector.

(2) For any process that removes or displaces material, controls shall be established so that the characters shall be at least 0.004 in. (0.10 mm) deep.

(3) For processes that do not remove or displace material (e.g., etching, laser annealing), the surface condition shall be clean, uncoated, and unpainted.

(4) Laser annealing shall be allowed only on stainless steel and aluminum.

(c) Items (a)(1) through (a)(7) listed in (a) above, with the markings arranged substantially as shown in [Figure HG-530.2](#) or [Figure HG-530.3](#), shall be marked with letters at least $\frac{5}{16}$ in. (8 mm) high [except as permitted in (f)] and in some conspicuous place on the boiler proper or on a nameplate at least $\frac{3}{64}$ in. (1.2 mm) thick permanently fastened to the boiler proper.

(d) The location of the marking shall be as follows:

(1) *Horizontal Tubular Flue Type Boilers:* on the front head above the central rows of tubes or flues.

(2) *Locomotive Firebox, Compact, or Vertical Firetube Type Boilers:* over or near the fire door or handhole or washout plug opening on the front end or side.

(3) *Watertube Type Boilers:* on a head of the top outlet drum. Waterwalls and headers shall carry identifying markings.

(4) *Split-Section and Section Firebox Type Wrought Boilers:* over or near the fire door or handhole or washout plug opening on the front end or side. Each section shall carry identifying markings.

(5) *Scotch Type Boilers:* on either side of the shell near the normal water level line adjacent to the front tubesheet.

(e) On any of the above type boilers where there is not sufficient space in the places designated and on other types and new designs of boilers, the marking shall be located in a conspicuous place.

(f) When there is insufficient space for the marking required above, smaller letter dimensions may be used, provided

(1) marking shall be as required in (a) through (c) above, and

(2) character size shall be no smaller than $\frac{5}{32}$ in. (4 mm)

**Figure HG-530.2
Steam and Water Boilers Form of Marking on
Completed Boilers or Their Nameplates
(Not Applicable for Boilers Constructed Primarily
of Cast Iron)**

	Certified by

	(Name of Manufacturer)
	¹ MAWP, Steam _____
	¹ MAWP, Water _____
	¹ Maximum Water Temp. _____
	² Heating surface _____ boiler
	³ Heating surface _____ water wall
	Minimum relief valve capacity _____
	Manufacturer's serial no. _____
	⁴ Year built _____

GENERAL NOTE: Acceptable abbreviations of any of the wording may be used.

NOTES:

- (1) For steam only boilers, MAWP Water and Maximum Water Temperature markings are optional.
- (2) Kilowatt power input for electric boilers.
- (3) List each type of surface separately. May be omitted if type heating surface is not present.
- (4) May be omitted when year built is prefix to serial number (see [HG-530.1](#)).

(g) The required markings on the boiler proper shall not be covered with insulating or other material unless at least one of the following conditions is met:

(1) The required markings are duplicated and marked directly on the boiler casing in some conspicuous place using letters and numerals at least $\frac{5}{16}$ in. (8 mm) high.

(2) An opening with a removable cover is provided in the jacket or other form of casing so that, when removed, the required markings or nameplate on the boiler proper can be viewed.

(3) The required markings are duplicated and marked on a nonferrous nameplate at least 3 in. × 4 in. (75 mm × 100 mm) size with letters at least $\frac{1}{8}$ in. (3 mm) high. The nameplate is permanently attached to the casing in some conspicuous place by mechanical means or by an adhesive system meeting the requirements of [Mandatory Appendix 3](#).

(h) The Certification Mark may be preapplied to a nameplate. The nameplate may be attached to the boiler after the final fabrication and examination sequence but before the hydrostatic test, provided the procedure for sequence of marking is described in the manufacturer's accepted quality control system.

**Figure HG-530.3
Boilers Suitable for Water Only
Form of Marking on Completed Boilers or Their
Nameplates
(Not Applicable for Boilers Constructed Primarily
of Cast Iron)**

	Certified by

	(Name of Manufacturer)
	MAWP, Water _____
	Maximum Water Temp. _____
	¹ Heating surface _____ boiler
	² Heating surface _____ water wall
	Minimum relief valve capacity _____
	Manufacturer's serial no. _____
	³ Year built _____

GENERAL NOTE: Acceptable abbreviations of any of the wording may be used.

NOTES:

- (1) Kilowatt power input for electric boilers.
- (2) List each type of surface separately. May be omitted if type heating surface is not present.
- (3) May be omitted when year built is prefix to serial number (see [HG-530.1](#)).

(i) The Certification Mark shall not be used by an organization to which it was not issued.

HG-530.2 Marking Requirements for Cast Iron or Cast Aluminum Boilers. (23)

(a) All cast iron boiler parts or sections to which the Certification Mark is to be applied shall be built according to the rules of this Section by a Manufacturer⁸ who is in possession of a Certification Mark and a valid Certificate of Authorization. Each boiler section, including end and intermediate cored sections, shall be cast or etched with the Certification Mark shown in [Figure HG-530.1](#) with the H designator and with the following data cast in letters or numerals at least $\frac{5}{16}$ in. (8 mm) high:

(1) the boiler or parts Manufacturer's⁸ name or acceptable abbreviation, preceded by the words "Certified by;" (or "Cert. by" on cast boiler sections only where space for marking is limited; the abbreviation "Cert. by" shall not be used on nameplates)⁹

(2) maximum allowable working pressure^{9, 10}

(3) pattern number

(4) casting date

Arrangement of data cast or etched on sections shall be substantially as shown in [Figure HG-530.4](#) for cast iron steam or hot water heating boilers or [Figure HG-530.5](#) for cast iron hot water heating boilers.

Figure HG-530.4
Steam and Water Boilers
Form of Data Cast or Marked on Cast Iron Boiler
Sections

GENERAL NOTE: For (1) through (4), refer to [HG-530.2\(a\)\(1\)](#) through [HG-530.2\(a\)\(4\)](#).

The process controls for etching shall be described in the Quality Control System. Etched information shall have a minimum depth of 0.004 in. (0.1 mm) and shall not compromise the minimum wall thickness. The surface condition where etching is applied shall be clean, uncoated, and unpainted.

Other data may be cast or etched on the sections. The marking “ASME” or “ASME standard” shall not be used.

Figure HG-530.5
Boilers Suitable for Water Only
Form of Data Cast or Marked on Cast Iron Boiler
Sections

GENERAL NOTE: For (1) through (4), refer to [HG-530.2\(a\)\(1\)](#) through [HG-530.2\(a\)\(4\)](#).

(b) All cast aluminum boiler parts or sections to which the Certification Mark is to be applied shall be built according to the rules of this Section by a Manufacturer⁸ who is in possession of a Certification Mark and a valid Certificate of Authorization. Each boiler section, including end and intermediate cored sections, shall be cast, stamped, or etched with the Certification Mark shown in [Figure HG-530.1](#) with the H designator and with the following data cast in letters or numerals at least $\frac{5}{16}$ in. (8 mm) high:

(1) the boiler or parts Manufacturer’s⁸ name or acceptable abbreviation, preceded by the words “Certified by:” (or “Cert. by” on cast boiler sections only where space for marking is limited; the abbreviation “Cert. by” shall not be used on nameplates)⁹

(2) maximum allowable working pressure^{9, 10}

(3) pattern number

(4) casting date

(5) the material specification identification number and grade or an abbreviation traceable to the material certification^{9, 10}

In lieu of directly marking the castings, the data in items (b)(1), (b)(2), and (b)(5) may be stamped or etched on a permanently attached $\frac{3}{64}$ in. (0.2 mm) thick nonferrous nameplate using letters and numerals at least $\frac{1}{8}$ in. (3 mm) high.

Arrangement of data marked on sections or on a nameplate shall be substantially as shown in [Figure HG-530.6](#) for cast aluminum hot water heating boilers.

The process controls for etching shall be described in the Quality Control System. Etched information shall have a minimum depth of 0.004 in. (0.1 mm) and shall not compromise the minimum wall thickness. The surface condition where etching is applied shall be clean, uncoated, and unpainted.

Other data may be cast, stamped, or etched on the sections. The marking “ASME” or “ASME standard” shall not be used.

(c) When the boiler size and number of sections have been decided, the completed boiler shall be marked with the Certification Mark shown in [Figure HG-530.1](#) with the H designator and with the following data:

(1) the Shop Assembler’s name preceded by the words “Certified by”

(2) maximum allowable working pressure

(3) pressure relief valve capacity (minimum), as determined according to [HG-402A.1\(i\)](#) and [HG-402A.2\(f\)](#)

(4) maximum water temperature

(d) The Shop Assembler that is in possession of a Certification Mark and valid Certificate of Authorization shall be one of the following:

(1) the shop that assembles sections into boilers, performs the hydrostatic test, and installs the nameplate

(2) the shop that installs the nameplate on a boiler, previously assembled and hydrotested by another authorized Certificate Holder

**Figure HG-530.6
Boilers Suitable for Water Only
Form of Data Cast or Marked on Cast Aluminum
Boiler Sections**

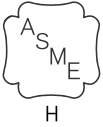
	Certified by
	(1) _____
	Name of Manufacturer
	MAWP, Water _____ (2)
	(3) _____
	(Pattern number)
	(4) _____
	(Casting date)
	(5) _____
	(Material specification/grade)

GENERAL NOTE: For (1) through (4), refer to [HG-530.2\(b\)\(1\)](#) through [HG-530.2\(b\)\(5\)](#).

(3) the shop that only installs the nameplate on a boiler.

(e) The markings for the completed boiler shall be arranged substantially as shown in [Figure HG-530.7](#) or [Figure HG-530.8](#).

(f) Data for more than one size boiler in a model series may be listed on the nameplate. When different model numbers having the same number of sections and jacket length have different minimum pressure relief valve capacities, the highest value shall be listed. The following additional information shall be included for each size listed:

- (1) boiler model number
- (2) number of sections
- (3) jacket length
- (4) the statement: "To determine boiler size, count the number of sections or measure the jacket length"
- (g) The provisions of (c) above shall be met using one of the following methods:

(1) stamping or etching the required markings on a nonferrous nameplate at least 3 in. × 4 in. (75 mm × 100 mm) in size and $\frac{3}{64}$ in. (1.2 mm) thick using letters and numerals at least $\frac{1}{8}$ in. (3 mm) high and permanently attaching the nameplate to the boiler proper in some conspicuous place. The nameplate shall not be covered with insulating or other material except that when a jacket or other form of casing is applied to a boiler, an opening with a removable cover shall be provided for viewing the required markings.

(2) stamping or etching the required markings directly into the boiler jacket in some conspicuous place using letters and numerals at least $\frac{5}{16}$ in. (8 mm) high.

(3) stamping or etching the required markings on a nonferrous nameplate at least 3 in. × 4 in. (75 mm × 100 mm) in size using letters and numerals at least $\frac{1}{8}$ in. (3 mm) high and permanently attaching the nameplate to the casing in some conspicuous place by mechanical means or by an adhesive system.

(4) marking the required markings on a nonmetallic nameplate at least 3 in. × 4 in. (75 mm × 100 mm) in size using letters and numerals at least $\frac{1}{8}$ in. (3 mm) high and permanently attaching the nameplate to the casing in some conspicuous place by an adhesive system.

(5) the following pertain to the above methods where applicable:

**Figure HG-530.7
Steam and Water Boilers
Form of Marking on Completed Cast Iron Boilers or
Their Nameplates**

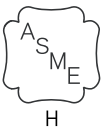
	Certified by

	Name of Shop Assembler
	MAWP, Steam _____
	MAWP, Water _____
	Maximum Water Temp. _____
	Minimum relief valve capacity _____

**Figure HG-530.8
Boilers Suitable for Water Only
Form of Marking on Completed Cast Iron or Cast
Aluminum Boilers or Their Nameplates**

	Certified by

	Name of Shop Assembler
	MAWP, Water _____
	Maximum Water Temp. _____
	Minimum relief valve capacity _____

(-a) the nameplate and the adhesive system shall meet the requirements of [Mandatory Appendix 3](#). Other data may be marked on the jacket or the nameplate provided the required markings are distinct and separate from the other data. The marking “ASME” or “ASME standard” shall not be used.

(-b) the Certification Mark may be preapplied to a nameplate.

(-c) the nameplate may be attached to the casing of a cast iron or cast aluminum boiler by the Manufacturer or Shop Assembler at a plant other than that shown on his Certificate of Authorization provided the plant is owned by the Certificate Holder and the nameplate’s control and use is addressed in his Quality Control Manual.

(-d) the Certification Mark shall not be used by an organization to which it was not issued.

HG-530.3 Modular Boilers. Requirements for marking modular boilers are given in [Article 8](#).

(23) **HG-531 Marking of Parts and Accessories**

(a) Parts and accessories of boilers for which Manufacturer’s Partial Data Reports are required by [HG-520.2](#) shall be marked in one of the following manners:

(1) the official Certification Mark shown in [Figure HG-530.1](#) with the H designator above the word “Part” along with the following:

- (-a) the part manufacturer’s name
- (-b) the part manufacturer’s serial number

(2) the official Certification Mark shown in [Figure HG-530.1](#) with the PRT IV designator along with the following:

- (-a) the part manufacturer’s name
- (-b) the part manufacturer’s serial number

(b) The markings for the completed part or accessory shall be arranged substantially as shown in [Figure HG-531.1](#) or [Figure HG-531.2](#).

(c) Each individual part or accessory shall be marked.

(d) Small parts [5-in. (125-mm) O.D. and under] may be marked with an identification acceptable to the Inspector (e.g., a bar code, etching, or paint stencil) and traceable to the Manufacturer’s Partial Data Report in lieu of the markings described in (a) and (b). Such marking shall be of a type that will remain visible until the part is installed. The Certification Mark is not required.

(e) A nameplate furnished with the Certification Mark on parts may be removed during the completion of a boiler if all of the following conditions are satisfied:

- (1) The nameplate interferes with further fabrication or service.
- (2) The Manufacturer of the completed boiler has agreement from the Authorized Inspector to remove the nameplate.
- (3) The removal of the nameplate shall be noted in the Remarks section of the Manufacturer’s Data Report.
- (4) The removed nameplate shall be destroyed.

(f) No part or accessory of a boiler may be marked with the Certification Mark shown in [Figure HG-530.1](#) unless so specified in the Code. The markings “ASME” or “ASME standard” shall not be used.

(g) Manufacturers and assemblers of parts or accessories who do not perform or assume any design responsibility for the parts or accessories they manufacture shall identify on the Manufacturer’s Partial Data Report the organization responsible for the design of the part or accessory.

HG-532 Marking of Field-Assembled Wrought Boilers (23)

HG-532.1 Responsibility of Manufacturer of Boiler. When a boiler manufactured of wrought material is furnished by one manufacturer and is not assembled and subjected to a hydrostatic test prior to shipment, the manufacturer of the boiler shall record on a Manufacturer’s Data Report Form, [Form H-2](#) or [Form H-3](#), all items completed on the boiler.

HG-532.2 Completion of Manufacturer’s Data Report Form. The Manufacturer’s Data Report Form shall be properly completed by the manufacturer and the Authorized Inspector, who shall sign the certificate of shop inspection certifying that each enumerated item that has been inspected at the shop conforms to the requirements of the ASME Code. The manufacturer in signing each Manufacturer’s Data Report Form shall state under his signature the expiration date on the Certificate of Authorization to use the Certification Mark.

HG-532.3 Applying the Certification Mark and Certifying Manufacturer’s Data Report Forms. Proper marking as required by [HG-530.1](#) shall be applied at the shop, and the Manufacturer’s Data Report Forms shall be signed by the same or different

Figure HG-531.1
Form of Marking on Part or Accessory —
H Designator

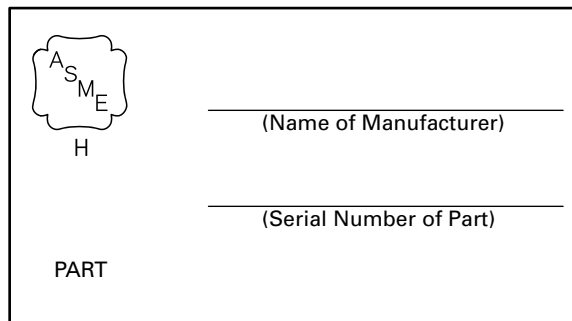

(23) **Figure HG-531.2**
Form of Marking on Part or Accessory —
PRT IV Designator

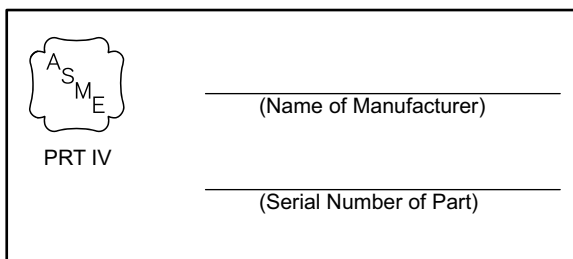

Inspectors who shall indicate the portions of the inspections made at the shop and in the field.

HG-533 Inspection and Marking of Field-Assembled Boiler Pressure Parts

(23) **HG-533.1 Authorized Assemblers and Welders.**

The assembly of any parts or subassemblies of the boiler that requires welding shall be made by one possessing a heating boiler Certificate of Authorization. The welding of any parts or subassemblies during field assembly shall be done by persons who meet the requirements of [HW-610](#).

(23) **HG-533.2 Completion of Manufacturer's Data Report Forms.**

When the assembly is performed by anyone other than the manufacturer of the boiler, the Manufacturer's Data Report Form shall be properly filled in in accordance with [HG-532](#) and forwarded to the assembler who shall be responsible for the proper completion of the Manufacturer's Data Report Form, filling in such items as are not filled in at the manufacturer's shop, and sign the Manufacturer's Data Report Form as the "assembler" or "assembling organization" instead of as the "manufacturer." He shall also append, above his signature, the statement: "We certify that the field assembly of all parts conform with the requirements of the ASME Boiler and Pressure Vessel Code."

(23) **HG-533.3 Field Inspection by Authorized Inspector.**

The field inspection shall be made by an Authorized Inspector (as defined in [HG-515.3](#)) and the Inspector shall make such inspections as he believes are needed to enable him to certify that the boiler has been constructed in accordance with the Code. Properly filled-in Manufacturer's Data Report Forms, together with the Inspector's own inspection, shall constitute his authority to sign the Certificate of Field Inspection.

HG-533.4 Application of Assembler's Certification Mark. The Assembler's Certification Mark with H designator, together with the assembler's

name or an acceptable abbreviation, shall be applied in the field on the boiler near the marking called for in [HG-530.1](#), when the assembly is accepted by the Authorized Inspector.

HG-533.5 Application for Certification Mark With H Designator.

Applicants for Certification Mark with H designator to be used only in the field assembly of heating boilers shall so state on the application form, and the Certificate of Authorization issued to such applicants shall show that the authorization to use the Certification Mark with H designator is limited to the field assembly of welded boilers constructed to Section IV (see [HG-540](#)).

(23) **HG-533.6 Certificate of Field Inspection.**

The Certificate of Field Inspection on the Manufacturer's Data Report Form shall be completed by the Authorized Inspector. The assembler or assembling organization shall have the responsibility for forwarding and filing of Manufacturer's Data Reports as required by [HG-520.1\(a\)](#) and [HG-520.1\(b\)](#).

(23) **HG-533.7 Mechanical Field Assembly.**

For a boiler manufactured of wrought materials that has not been completed in the Manufacturer's shop, field assembly involving no welding does not need to be performed by a Company possessing a heating boiler Certificate of Authorization. However, when a boiler is not assembled by a Certificate Holder, the Manufacturer assuming responsibility for the completed boiler is responsible for providing for field inspection by an Authorized Inspector employed by the Manufacturer's Authorized Inspection Agency, and signature of the Certificate of Field Assembly Compliance on the Manufacturer's Data Report Form by a representative of the Manufacturer, after the required hydrostatic test has been completed. Application of an assembler Certification Mark with H designator in accordance with [HG-533.4](#) is not required.

HG-534 Field-Assembled Cast Iron Boilers

HG-534.1 Hydrostatic Tests. Each individual section or boiler part shall be subjected to a hydrostatic test as required in [HC-410](#) at the Manufacturer's plant prior to shipment.

HG-534.2 Marking. The marking on cast iron boilers shall meet the requirements of [HG-530.2](#). The nameplate shall be attached to the casing by the Manufacturer or Shop Assembler.

HG-534.3 Assembly Instructions. The Manufacturer shall provide printed instructions for the installer to follow when mechanically assembling the boiler, including instructions for performing the

hydrostatic test of the assembled boiler in [HC-410.1](#) and [HC-410.2](#).

HG-540 Certification Marks

(23) **HG-540.1 Authorization.** A Certificate of Authorization to use the Certification Mark with H, HLW, and/or PRT IV designator will be granted by the Society pursuant to the provisions of the following paragraphs. Stamps for applying the Certification Mark shall be obtained from the Society.

HG-540.2 Application for a Certificate of Authorization. Any organization desiring a Certificate of Authorization shall apply to ASME in accordance with the certification process of ASME CA-1. Authorization to use Certification Marks may be granted, renewed, suspended, or withdrawn as specified in ASME CA-1.

HG-540.3 Designated Oversight. The Manufacturer shall comply with the requirements of ASME CA-1 for designated oversight by use of an Authorized Inspection Agency or Certified Individual, as applicable.

HG-540.4 Quality Control System. Any Manufacturer or Shop Assembler holding or applying for a Certificate of Authorization shall have and demonstrate a quality control program that meets the requirements of ASME CA-1 and establishes that all Code requirements, including material, design, fabrication, examination (by the Manufacturer), inspection of boilers, vessels, parts (by the Authorized Inspector), pressure testing, and certification will be met.

(a) The quality control system shall be in accordance with the requirements of [Nonmandatory Appendix F](#), except for Cast Iron Boiler and Cast Aluminum Boiler Certificate Holders.

(b) The quality control system shall be in accordance with the requirements of [Article 5](#) of [Part HC](#) and [Part HA](#), respectively, for Cast Iron Boiler and Cast Aluminum Boiler Certificate Holders.

(c) For Manufacturers and Assemblers of parts who do not perform or assume any design responsibility for the parts they manufacture, the quality control system need only describe how the design documents, including specifications, drawings, and sketches that are received from

the purchaser of the part, are controlled and how the parts are controlled when in the custody of the parts' Manufacturer or Assembler.

HG-540.5 Evaluation for Authorization and Reauthorization. Before issuance or renewal of a Certificate of Authorization for use of the Certification Mark with the H, HLW, or PRT IV designator, the Manufacturer's facilities and organization are subject to a joint review by his Authorized Inspection Agency and an ASME Designee who is selected by the concerned legal jurisdiction, except that for Certification Mark with H designator (cast iron) and Certification Mark with H designator (cast aluminum), the review shall be yearly by an ASME Designee selected by ASME.

Certificates of Authorization will be endorsed to indicate the scope of activity authorized.

HG-540.6 Authorization of Changes. Any changes to be made in the quality control system shall be made and accepted in accordance with the requirements specified in ASME CA-1. For Manufacturers of multiple duplicate pressure vessels,¹¹ acceptance of these changes by the jurisdiction (if applicable) and an ASME Designee is also required.

For those areas where there is no jurisdiction, that function shall be performed by an ASME Designee selected by ASME. Where a jurisdiction does not review a Manufacturer's facility, that function shall be performed by an ASME Designee who is selected by the concerned legal jurisdiction. Where the jurisdiction is the Manufacturer's Inspection Agency, the joint review and joint report shall be made by the jurisdiction and an ASME Designee.

HG-540.7 Code Construction Before Receipt of Certificate of Authorization. When used to demonstrate his quality control system, a Manufacturer may start fabricating Code items before receipt of a Certificate of Authorization to use the Certification Mark under the conditions specified in ASME CA-1.

HG-540.8 Regulations on Use of the Certification Mark. ASME may, at any time, revise the regulations concerning the issuance and use of the Certification Mark as it deems appropriate, and all such regulations shall become binding upon the holders of any valid Certificates of Authorization.

ARTICLE 6

INSTRUMENTS, FITTINGS, AND CONTROLS

HG-600 GENERAL

All instruments, fittings, and controls described in this Article shall be installed prior to operation.

HG-601 FOR STEAM HEATING BOILERS

HG-602 Steam Gages

(a) Each steam boiler shall have a steam gage or a compound steam gage connected to its steam space or to its water column or to its steam connection. The gage or piping to the gage shall contain a siphon or equivalent device that will develop and maintain a water seal that will prevent steam from entering the gage tube. The piping shall be so arranged that the gage cannot be shut off from the boiler except by a cock placed in the pipe at the gage and provided with a tee- or lever-handle arranged to be parallel to the pipe in which it is located when the cock is open. The gage connection boiler tapping, external siphon, or piping to the boiler shall not be less than NPS $\frac{1}{4}$ (DN 8). Where steel or wrought iron pipe or tubing is used, the boiler connection and external siphon shall be not less than NPS $\frac{1}{2}$ (DN 15). Ferrous and nonferrous tubing having inside diameters at least equal to that of standard pipe sizes listed above may be substituted for pipe.

(b) The scale on the dial of a steam boiler gage shall be graduated to not less than 30 psi (200 kPa) nor more than 60 psi (414 kPa). The travel of the pointer from 0 psi to 30 psi (0 kPa to 200 kPa) pressure shall be at least 3 in. (75 mm).

HG-603 Water Gage Glasses

(a) Each steam boiler shall have one or more water gage glasses attached to the water column or boiler by means of valved fittings not less than NPS $\frac{1}{2}$ (DN 15), with the lower fitting provided with a drain valve of a type having an unrestricted drain opening not less than $\frac{1}{4}$ in. (6 mm) in diameter to facilitate cleaning. Gage glass replacement shall be possible with the boiler under pressure. Water glass fittings may be attached directly to a boiler.

Boilers having an internal vertical height of less than 10 in. (250 mm) may be equipped with a water level indicator of the Glass Bull's-Eye type provided the indicator is

of sufficient size to show the water at both normal operating and low-water cutoff levels.

(b) The lowest visible part of the water gage glass shall be at least 1 in. (25 mm) above the lowest permissible water level recommended by the boiler Manufacturer. With the boiler operating at this lowest permissible water level, there shall be no danger of overheating any part of the boiler.

Each boiler shall be provided at the time of the manufacture with a permanent marker indicating the lowest permissible water level. The marker shall be stamped, etched, or cast in metal; or it shall be a metallic plate attached by rivets, screws, or welding; or it shall consist of material with documented tests showing its suitability as a permanent marking for the application. This marker shall be visible at all times. Where the boiler is shipped with a jacket, this marker may be located on the jacket.

NOTE: Transparent material other than glass may be used for the water gage provided that the material will remain transparent and has proved suitable for the pressure, temperature, and corrosive conditions expected in service.

(c) In electric boilers of the submerged electrode type, the water gage glass shall be so located to indicate the water levels both at startup and under maximum steam load conditions as established by the manufacturer.

(d) In electric boilers of the resistance element type, the lowest visible part of the water gage shall be located at least 1 in. (25 mm) above the lowest permissible water level specified by the Manufacturer. Each electric boiler of this type shall also be equipped with an automatic low-water cutoff on each boiler pressure vessel so located as to automatically cut off the power supply to the heating elements before the surface of the water falls below the lowest visible part of the water gage glass.

(e) Tubular water glasses on electric boilers having a normal water content not exceeding 100 gal (300 L) shall be equipped with a protective shield.

(f) A water level indicator using an indirect sensing method may be used in lieu of an operating water gage glass; however, a water gauge glass must be installed and operable but may be shut off by valving. The water level indicator must be attached to a water column or directly to the boiler by means of valved fittings not less than NPS $\frac{1}{2}$ (DN 15). The device shall be provided with a drain valve of a type having an unrestricted drain

opening not less than $\frac{1}{4}$ in. (6 mm) in diameter to facilitate cleaning. Service and replacement of internal parts and/or housing shall be possible with the boiler under pressure.

HG-604 Water Column and Water Level Control Pipes

(a) The minimum size of ferrous or nonferrous pipes connecting a water column to a steam boiler shall be NPS 1 (DN 25). No outlet connections, except for damper regulator, feedwater regulator, steam gages, or apparatus that does not permit the escape of any steam or water except for manually operated blowdowns, shall be attached to a water column or the piping connecting a water column to a boiler (see HG-705 for introduction of feedwater into a boiler). If the water column, gage glass, low-water fuel cutoff, or other water level control device is connected to the boiler by pipe and fittings, no shutoff valves of any type shall be placed in such pipe, and a cross or equivalent fitting to which a drain valve and piping may be attached shall be placed in the water piping connection at every right angle turn to facilitate cleaning. The water column drain pipe and valve shall be not less than NPS $\frac{3}{4}$ (DN 20).

(b) The steam connections to the water column of a horizontal firetube wrought boiler shall be taken from the top of the shell or the upper part of the head, and the water connection shall be taken from a point not above the center line of the shell. For a cast iron boiler, the steam connection to the water column shall be taken from the top of an end section or the top of the steam header, and the water connection shall be made on an end section not less than 6 in. (150 mm) below the bottom connection to the water gage glass.

HG-605 Pressure Control

Each automatically fired steam boiler shall be protected from overpressure by two pressure-operated controls. These controls shall conform to UL 353, Standard for Limit Controls, and shall be accepted by a nationally recognized testing agency.

(a) Each individual automatically fired steam boiler shall have a safety limit control that will cut off the fuel supply to prevent steam pressure from exceeding the 15 psi (100 kPa) maximum allowable working pressure of the boiler. Each control shall be constructed to prevent a pressure setting above 15 psi (100 kPa).

(b) Each individual steam boiler shall have a control that will cut off the fuel supply when the pressure reaches an operating limit, which shall be less than the maximum allowable pressure.

(c) Shutoff valves of any type shall not be placed in the steam pressure connection between the boiler and the controls described in (a) and (b) above. These controls shall be protected with a siphon or equivalent means

of maintaining a water seal that will prevent steam from entering the control. The control connection boiler tapping, external siphon, or piping to the boiler shall be not less than NPS $\frac{1}{4}$ (DN 8). When a control incorporating a mercury switch is mounted on a siphon, the loop of the siphon shall be in a plane that is 90 deg (1.57 rad) from the plane of the switch.

(1) Steam pressure supply connections to a single pressure control using pipe of nonferrous material shall be not less than NPS $\frac{1}{4}$ (DN 8) for lengths up to and including 5 ft (1.5 m), and not less than NPS $\frac{1}{2}$ (DN 15) for lengths over 5 ft (1.5 m).

(2) Steam pressure supply connections to a single pressure control using pipe of ferrous material shall be not less than NPS $\frac{1}{2}$ (DN 15) for lengths up to and including 5 ft (1.5 m), and not less than NPS 1 (DN 25) for lengths over 5 ft (1.5 m).

(3) Pressure controls should have separate pressure connections; however, manifolding is permitted. When multiple controls are fed from a manifold, the manifold and common source connection to the boiler, for pipe of nonferrous material, shall be not less than NPS $\frac{1}{2}$ (DN 15) for lengths up to and including 5 ft (1.5 m), and not less than NPS $\frac{3}{4}$ (DN 20) for lengths over 5 ft (1.5 m). For manifolds using ferrous material, the manifold and common source connection to the boiler, shall be not less than NPS $\frac{3}{4}$ (DN 20) for lengths up to and including 5 ft (1.5 m) and not less than NPS $1\frac{1}{4}$ (DN 32) for lengths over 5 ft (1.5 m). Individual controls are to be piped from the manifold according to the provisions of (2) and (3) above.

(4) Tubing suitable for the temperatures and pressures involved, having an inside diameter at least equal to the required standard pipe sizes, may be substituted for pipe.

HG-606 Automatic Low-Water Fuel Cutoff and/or Water Feeding Device

(a) Each automatically fired steam boiler shall have an automatic low-water fuel cutoff, conforming to UL 353, Standard for Limit Controls, and accepted by a nationally recognized testing agency. This device shall be so located as to automatically cut off the fuel supply before the surface of the water falls below the lowest visible part of the water gage glass. If a water feeding device is installed, it shall be so constructed that the water inlet valve cannot feed water into the boiler through the float chamber and so located as to supply requisite feedwater.

(b) Such a fuel cutoff or water feeding device may be attached directly to a boiler. A fuel cutoff or water feeding device may also be installed in the tapped openings available for attaching a water glass directly to a boiler, provided the connections are made to the boiler with nonferrous tees or Y's not less than NPS $\frac{1}{2}$ (DN 15) between the boiler and the water glass so that the

water glass is attached directly and as close as possible to the boiler; the run of the tee or Y shall take the water glass fittings, and the side outlet or branch of the tee or Y shall take the fuel cutoff or water feeding device. The ends of all nipples shall be reamed to full-size diameter.

(c) Fuel cutoffs and water feeding devices embodying a separate chamber shall have a vertical drain pipe and a blowoff valve not less than NPS $\frac{3}{4}$ (DN 20), located at the lowest point in the water equalizing pipe connections so that the chamber and the equalizing pipe can be flushed and the device tested.

HG-610 FOR HOT WATER HEATING OR HOT WATER SUPPLY BOILERS

HG-611 Pressure or Altitude Gages

(a) Each hot water heating or hot water supply boiler shall have a pressure or altitude gage connected to it or to its flow connection in such a manner that it cannot be shut off from the boiler except by a cock with tee or lever handle, placed on the pipe near the gage. The handle of the cock shall be parallel to the pipe in which it is located when the cock is open.

(b) Mechanical Gages (Analog). The scale on the dial of the pressure or altitude gage shall be graduated to not less than $1\frac{1}{2}$ nor more than $3\frac{1}{2}$ times the pressure at which the pressure relief valve is set.

(c) Electronic gages used in lieu of mechanical gages shall meet the following requirements:

(1) Gage shall be powered from the boiler power supply and it shall have a display that remains on at all times. The gage shall have a backup power supply.

(2) The full scale range of the transducer must be a minimum of $1\frac{1}{2}$ times the pressure at which the pressure relief valve is set. It shall be accurate to within $\pm 2\%$ of full scale.

(3) The transducer shall have a media compatibility of both liquids and gases and be temperature compensated.

(4) The gage shall have an operating temperature range of 32°F to 250°F (0°C to 120°C) unless otherwise required by the application.

(d) Piping or tubing for pressure- or altitude-gage connections shall be of nonferrous metal when smaller than NPS 1 (DN 25).

HG-612 Thermometers/Temperature Sensors

Each hot water heating or hot water supply boiler shall have a thermometer or temperature sensor with display so located and connected that it shall be easily readable. The thermometer or sensor shall be so located that it shall at all times indicate the temperature of the water in the boiler at or near the outlet.

(a) Thermometer shall have a minimum reading of 70°F (20°C) or less.

(b) Thermometer shall have a maximum reading at least equal to 320°F (160°C) but not more than 400°F (205°C).

(c) Electronic temperature sensor used in lieu of a thermometer shall meet the following requirements:

(1) The sensor shall be powered from the boiler power supply, and it shall have a display that remains on at all times. The sensor shall have a backup power supply.

(2) The full scale of the sensor and display must be a minimum of 70°F (20°C) to 320°F (160°C). It shall be accurate to within ± 1 deg.

(3) The sensor shall have a minimum operating temperature range of 32°F to 300°F (0°C to 150°C).

(4) The display shall have an ambient operating temperature range of 32°F to 120°F (0°C to 50°C) unless otherwise required by the application.

HG-613 Temperature Control

Each automatically fired hot water heating or hot water supply boiler shall be protected from over-temperature by two temperature-operated controls. These temperature control devices shall conform to UL 353, Standard for Limit Controls, and shall be accepted by a nationally recognized testing agency.

(a) Each individual automatically fired hot water heating or hot water supply boiler shall have a high temperature limit control that will cut off the fuel supply at or below the marked maximum water temperature at the boiler outlet. This control shall be constructed to prevent a temperature setting above the maximum.

(b) Each individual hot water heating or hot water supply boiler shall have a control that will cut off the fuel supply when the system water temperature reaches a preset operating temperature, which shall be less than the maximum water temperature.

HG-614 Low-Water Fuel Cutoff

(a) Each automatically fired hot water heating or hot water supply boiler with heat input greater than 400,000 Btu/hr (117 kW) shall have an automatic low-water fuel cutoff that has been designed for hot water service conforming to UL 353, Standard for Limit Controls, and accepted by a nationally recognized testing agency. This device shall be so located as to automatically cut off the fuel supply when the surface of the water falls to the level established in (b) below (see Figure HG-703.2).

(b) As there is no normal waterline to be maintained in a hot water boiler, any location of the low-water fuel cutoff above the lowest safe permissible water level established by the boiler manufacturer is satisfactory.

(c) A coil-type boiler or a watertube boiler with heat input greater than 400,000 Btu/hr (117 kW) requiring forced circulation to prevent overheating of the coils or tubes shall have a flow-sensing device installed in lieu of the low-water fuel cutoff required in (a) above to automatically cut off the fuel supply when the circulating flow is interrupted.

(d) A means shall be provided for testing the operation of the external low-water fuel cutoff without resorting to draining the entire system. Such means shall not render the device inoperable except as described as follows. If the means temporarily isolates the device from the boiler during this testing, it shall automatically return to its normal position. The connection may be so arranged that the device cannot be shut off from the boiler except by a cock placed at the device and provided with a tee or lever-handle arranged to be parallel to the pipe in which it is located when the cock is open.

HG-620 FOR ALL BOILERS

HG-621 Instruments, Fittings, and Controls Mounted Inside Boiler Jackets

Any or all instruments, fittings, and controls required by these rules may be installed inside of boiler jackets provided the water gage on a steam boiler is accessible without the use of tools and provided the water gage and pressure gage on a steam boiler or the thermometer and pressure gage on a water boiler are visible through an opening or openings at all times.

HG-630 ELECTRIC WIRING

HG-631 Electrical Code Compliance

All field wiring for controls, heat generating apparatus, and other appurtenances necessary for the operation of the boiler or boilers should be installed in accordance with the provisions of the National Electric Code and/or should comply with the applicable local electrical codes. All boilers supplied with factory mounted and wired controls, heat generating apparatus, and other appurtenances necessary for the operation of the boilers should be installed in accordance with the provisions of the nationally recognized standards such as those of HG-640.¹²

HG-632 Type Circuitry to be Used

Whether field or factory wired, the control circuitry shall be positively grounded and shall operate at 150 V or less. One of the two following systems may be employed to provide the control circuit.

(a) *Two-Wire Nominal 120 V System With Separate Equipment Ground Conductor*

(1) This system shall consist of the line, neutral, and equipment ground conductors. The control panel frame and associated control circuitry metallic enclosures shall be electrically continuous and be bonded to the equipment ground conductor.

(2) The equipment ground conductor and the neutral conductor shall be bonded together at their origin in the electrical system as required by the NEC.¹³

(3) The line side of the control circuit shall be provided with a time delay fuse sized as small as practicable.

(b) *Two-Wire Nominal 120 V System Obtained By Using an Isolation Transformer*

(1) The two-wire control circuit shall be obtained from the secondary side of an isolation transformer. One wire from the secondary of this transformer shall be electrically continuous and shall be bonded to a convenient cold water pipe. All metallic enclosures of control components shall be securely bonded to this ground control circuit wire. The primary side of the isolation transformer will normally be a two-wire source with a potential of 230 V or 208 V or 440 V.

(2) Both sides of the two-wire primary circuit shall be fused. The hot leg on the load side of the isolation transformer shall be fused as small as practicable and in no case fused above the rating of the isolation transformer.

HG-633 Limit Controls

Limit controls shall be wired on the hot or line side of the control circuit.

HG-634 Shutdown Switches and Circuit Breakers

A manually operated remote heating plant shutdown switch or circuit breaker should be located just outside the boiler room door and marked for easy identification. Consideration should also be given to the type and location of the switch to safeguard against tampering. If the boiler room door is on the building exterior the switch should be located just inside the door. If there is more than one door to the boiler room, there should be a switch located at each door.

(a) For atmospheric-gas burners, and oil burners where a fan is on a common shaft with the oil pump, the complete burner and controls should be shut off.

(b) For power burners with detached auxiliaries, only the fuel input supply to the firebox need be shut off.

HG-640 CONTROLS AND HEAT GENERATING APPARATUS

(a) Oil and gas-fired and electrically heated boilers should be equipped with suitable primary (flame safeguard) safety controls, safety limit switches, and burners or electric elements as required by a nationally recognized standard.¹²

(b) The symbol of the certifying organization¹⁴ that has investigated such equipment as having complied with a nationally recognized standard shall be affixed to the equipment and shall be considered as evidence that the unit was manufactured in accordance with that standard.

ARTICLE 7

INSTALLATION REQUIREMENTS

HG-700 INSTALLATION REQUIREMENTS, ALL BOILERS

HG-701 Mounting Pressure Relief Valves

HG-701.1 Permissible Mounting. Pressure relief valves shall be located in the top or side¹⁵ of the boiler. They shall be connected directly to a tapped or flanged opening in the boiler, to a fitting connected to the boiler by a short nipple, to a Y-base, or to a valveless header connecting steam or water outlets on the same boiler. Coil or header type boilers shall have the pressure relief valve located on the steam or hot water outlet end. Pressure relief valves shall be installed with their spindles vertical. The opening or connection between the boiler and any pressure relief valve shall have at least an area equal to the nominal inside area of a Schedule 80 pipe (as defined by ASME B36.10M) of the same nominal pipe size as the inlet of the valve.

HG-701.2 Requirements for Common Connections for Two or More Valves.

(a) When a boiler is fitted with two or more pressure relief valves on one connection, this connection shall have a cross-sectional area not less than the combined areas of inlet connections of all the pressure relief valves with which it connects.

(b) When a Y-base is used, the inlet area shall be not less than the combined outlet areas. When the size of the boiler requires a pressure relief valve larger than 4½ in. (115 mm) in diameter, two or more valves having the required combined capacity shall be used. When two or more valves are used on a boiler, they may be single, directly attached, or mounted on a Y-base.

HG-701.3 Threaded Connections. A threaded connection may be used for attaching a valve.

HG-701.4 Prohibited Mountings. Pressure relief valves shall not be connected to an internal pipe in the boiler.

HG-701.5 Use of Shutoff Valves Prohibited. No shutoff of any description shall be placed between the pressure relief valve and the boiler, or on discharge pipes between such valves and the atmosphere.

HG-701.6 Pressure Relief Valve Discharge Piping.

(a) A discharge pipe shall be used. Its internal cross-sectional area shall be not less than the full area of the valve outlet or of the total of the valve outlets discharging thereinto and shall be as short and straight as possible and so arranged as to avoid undue stress on the valve or valves. A union may be installed in the discharge piping close to the valve outlet. When an elbow is placed on a pressure relief valve discharge pipe, it shall be located close to the valve outlet downstream of the union.

(b) The discharge from pressure relief valves shall be so arranged that there will be no danger of scalding attendants. The pressure relief valve discharge shall be piped away from the boiler to the point of discharge, and there shall be provisions made for properly draining the piping. The size and arrangement of discharge piping shall be independent of other discharge piping and shall be such that any pressure that may exist or develop will not reduce the relieving capacity of the relieving devices below that required to protect the boiler.

(c) The minimum pressure rating of the discharge piping shall be at least equal to the MAWP marked on the boiler, but in no case shall it be less than 30 psi (200 kPa).

(d) The temperature rating of the discharge piping shall be at least equal to the maximum water temperature marked on the boiler rating plate or 250°F (120°C) if no temperature is marked.

HG-701.7 Temperature and Pressure Relief Valves. Hot water heating or supply boilers limited to a water temperature of 210°F (99°C) may have one or more capacity-certified temperature and pressure relief valves installed. The requirements of HG-701.1 through HG-701.6 shall be met, except as follows:

(a) A Y-type fitting shall not be used.

(b) If additional valves are used, they shall be temperature and pressure relief valves.

(c) When the temperature and pressure relief valve is mounted directly on the boiler with no more than 4 in. (100 mm) maximum interconnecting piping, the valve may be installed in the horizontal position with the outlet pointed down.

HG-703 Piping¹⁶

HG-703.1 Provisions for Expansion and Contraction. Provisions shall be made for the expansion and contraction of steam and hot water mains connected to boilers by providing substantial anchorage at suitable points and by providing swing joints when boilers are installed in batteries, so there will be no undue strain transmitted to the boilers. See [Figures HG-703.1\(a\)](#), [HG-703.1\(b\)](#), and [HG-703.2](#) for typical schematic arrangements of piping incorporating strain absorbing joints for steam and hot water heating boilers.

HG-703.2 Return Pipe Connections.

(a) The return pipe connections of each boiler supplying a gravity return steam heating system shall be so arranged as to form a loop substantially as shown in [Figure HG-703.1\(b\)](#) so that the water in each boiler cannot be forced out below the safe water level.

(b) For hand-fired boilers with a normal grate line, the recommended pipe sizes detailed as “A” in [Figures HG-703.1\(a\)](#) and [HG-703.1\(b\)](#) are NPS 1½ (DN 40) for 4 ft² (0.37 m²) or less firebox area at the normal grate line, NPS 2½ (DN 65) for areas more than 4 ft² (0.37 m²) up to 14.9 ft² (1.4 m²), and NPS 4 (DN 100) for 15 ft² (1.4 m²) or more.

(c) For automatically fired boilers that do not have a normal grate line, the recommended pipe sizes detailed as “A” in [Figures HG-703.1\(a\)](#) and [HG-703.1\(b\)](#) are NPS 1½ (DN 40) for boilers with minimum pressure relief valve relieving capacity 250 lb/hr (113 kg/hr) or less, NPS 2½ (DN 65) for boilers with minimum pressure relief valve relieving capacity from 251 lb/hr (114 kg/hr) to 2,000 lb/hr (900 kg/hr), inclusive, and NPS 4 (DN 100) for boilers with more than 2,000 lb/hr (900 kg/hr) minimum pressure relief valve relieving capacity.

(d) Provision shall be made for cleaning the interior of the return piping at or close to the boiler. Washout openings may be used for return pipe connections and the washout plug placed in a tee or a cross so that the plug is directly opposite and as close as possible to the opening in the boiler.

HG-705 Feedwater and Makeup Water Connections

(a) *Steam Boilers.* Feedwater or water treatment shall be introduced into a boiler through the return piping system. Alternatively, feedwater or water treatment may be introduced through an independent connection. The water flow from the independent connection shall not discharge directly against parts of the boiler exposed to direct radiant heat from the fire. Feedwater or water treatment shall not be introduced through openings or connections provided for inspection or cleaning, pressure relief valve, water column, water gage glass, or pressure gage.

The feedwater pipe shall be provided with a check valve (or a backflow preventer containing a check valve¹⁷) near the boiler. A stop valve or cock shall be installed either upstream or downstream of the check valve (or backflow preventer containing a check valve¹⁷).

(b) *Hot Water Boilers.* Makeup water may be introduced into a boiler through the piping system or through an independent connection. The water flow from the independent connection shall not discharge directly against parts of the boiler exposed to direct radiant heat from the fire. Makeup water shall not be introduced through openings or connections provided exclusively for inspection or cleaning, pressure relief valve, pressure gage, or temperature gage. The makeup water pipe shall be provided with a check valve (or a backflow preventer containing a check valve¹⁷) near the boiler. A stop valve or cock shall be installed either upstream or downstream of the check valve (or backflow preventer containing a check valve¹⁷).

(c) The minimum pressure rating of all check valves, stop valves, cocks, or backflow preventers with check valve(s) shall be at least equal to the pressure marked on the boiler, and the temperature rating of such check valves, stop valves, cocks, or backflow preventers, including all internal components, shall be not less than 250°F (120°C).

HG-707 Oil Heaters

(a) A heater for oil or other liquid harmful to boiler operation shall not be installed directly in the steam or water space within a boiler.

(b) Where an external type heater for such service is used, means shall be provided to prevent the introduction into the boiler of oil or other liquid harmful to boiler operation.

HG-708 Storage Tanks for Hot Water Supply Systems

If a system is to utilize a storage tank that exceeds the capacity exception of [HLW-101](#), the tank shall be constructed in accordance with the rules of [Part HLW](#), Section VIII, Division 1; or Section X. For tanks constructed to Section X, the maximum allowable temperature marked on the tank shall equal or exceed the maximum water temperature marked on the boiler.

HG-709 Provisions for Thermal Expansion in Hot Water Systems

All hot water heating systems incorporating hot water tanks or fluid relief columns shall be so installed as to prevent freezing under normal operating conditions.

Figure HG-703.1(a)
Steam Boilers in Battery — Pumped Return — Acceptable Piping Installation

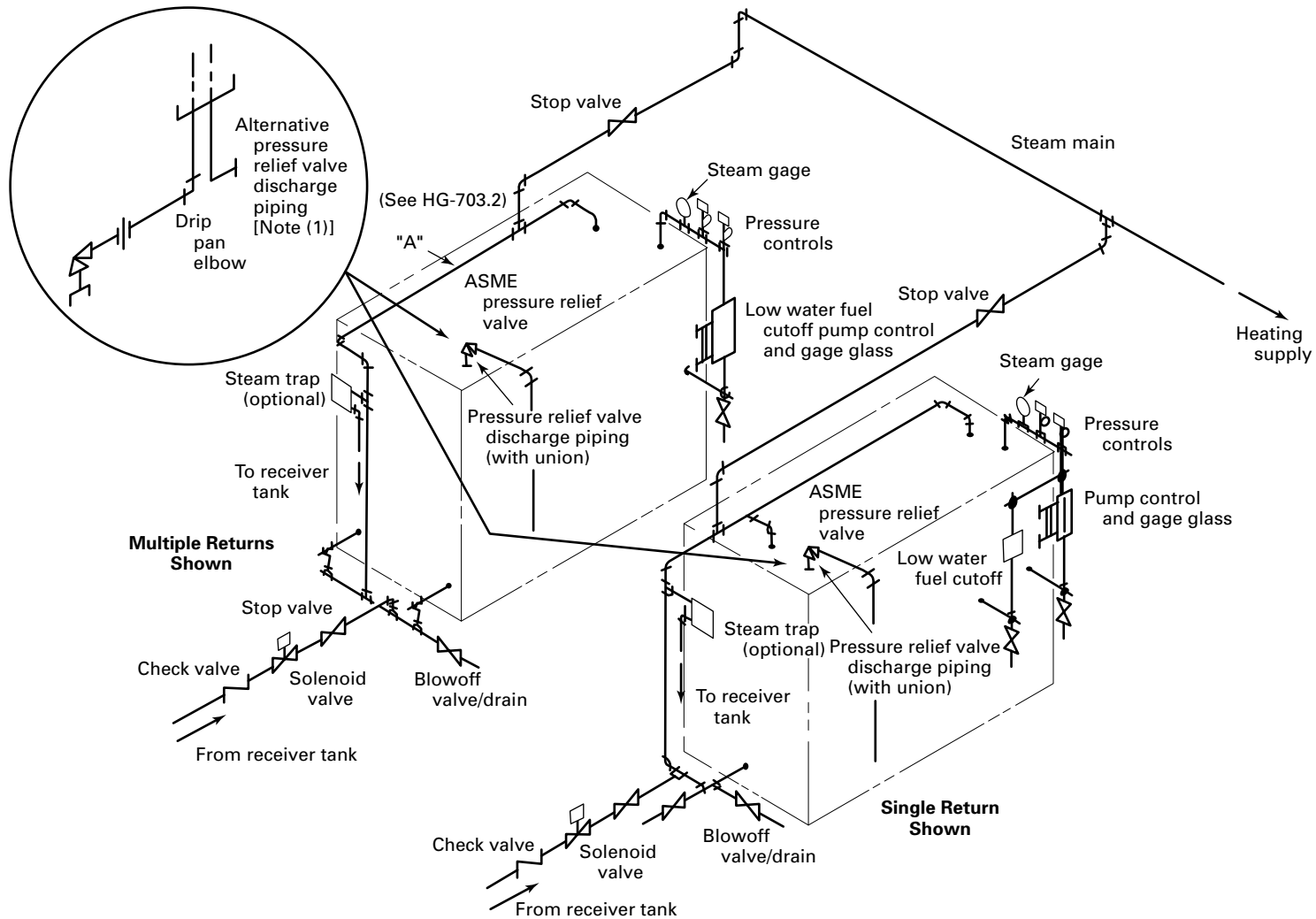

58

ASME BPVC.IV-2023

GENERAL NOTES:

- (a) Return connections shown for a multiple boiler installation may not always insure that the system will operate properly. In order to maintain proper water levels in multiple boiler installations, it may be necessary to install supplementary controls or suitable devices.
- (b) Plumbing codes may require the installation of a reduced pressure principle backflow preventer on a boiler when the makeup water source is from a potable water supply.

NOTE: (1) Recommended for 1 in. (DN 25) and larger pressure relief valve discharge.

Figure HG-703.1(b)
Steam Boilers in Battery — Gravity Return — Acceptable Piping Installation

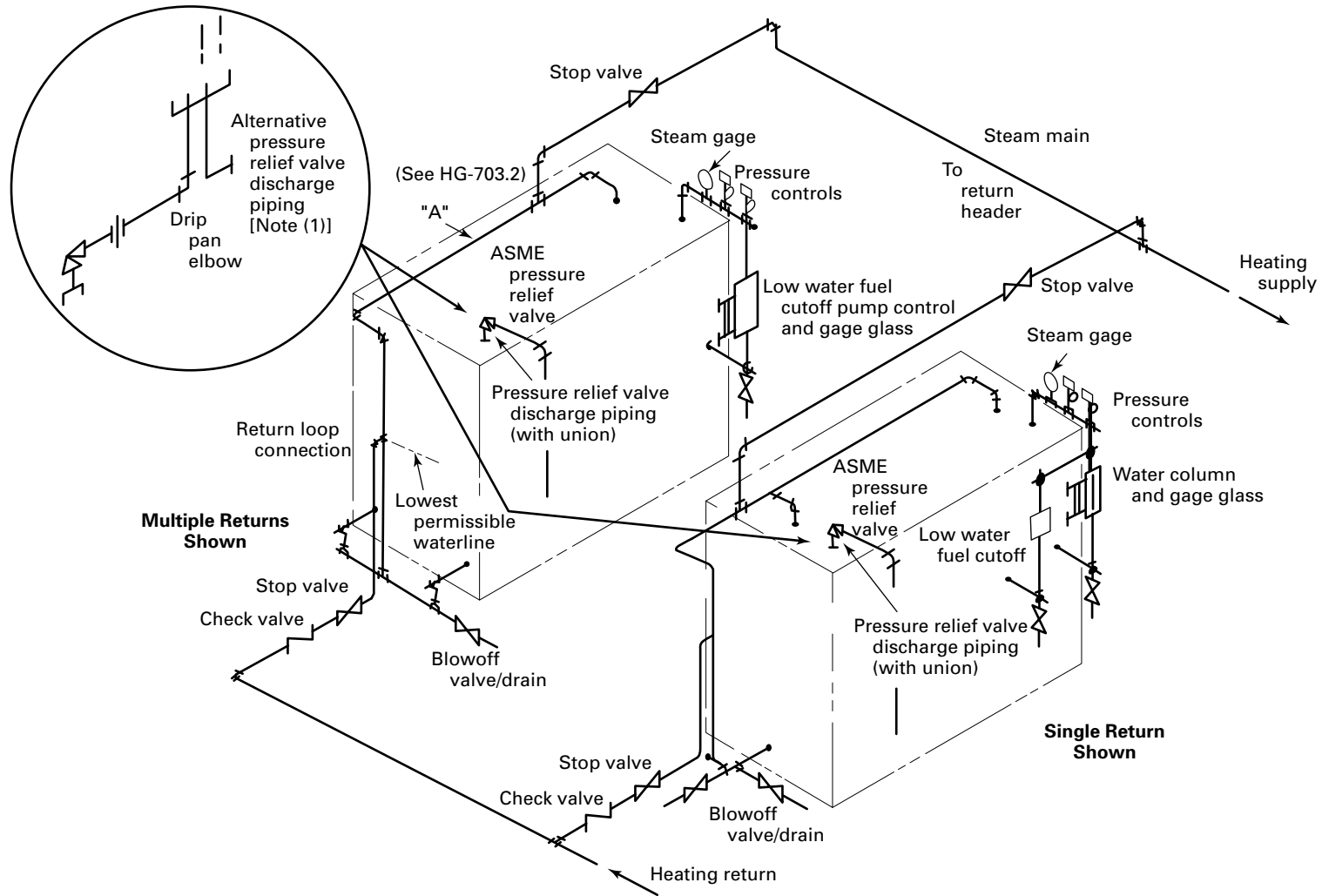

59

ASME BPVC-IV-2023

GENERAL NOTES:

- (a) Return connections shown for a multiple boiler installation may not always insure that the system will operate properly. In order to maintain proper water levels in multiple boiler installations, it may be necessary to install supplementary controls or suitable devices.
- (b) Plumbing codes may require the installation of a reduced pressure principle backflow preventer on a boiler when the makeup water source is from a potable water supply.

NOTE: (1) Recommended for 1 in. (DN 25) and larger pressure relief valve discharge.

**Figure HG-703.2
Hot Water Boilers in Battery — Acceptable Piping Installation**

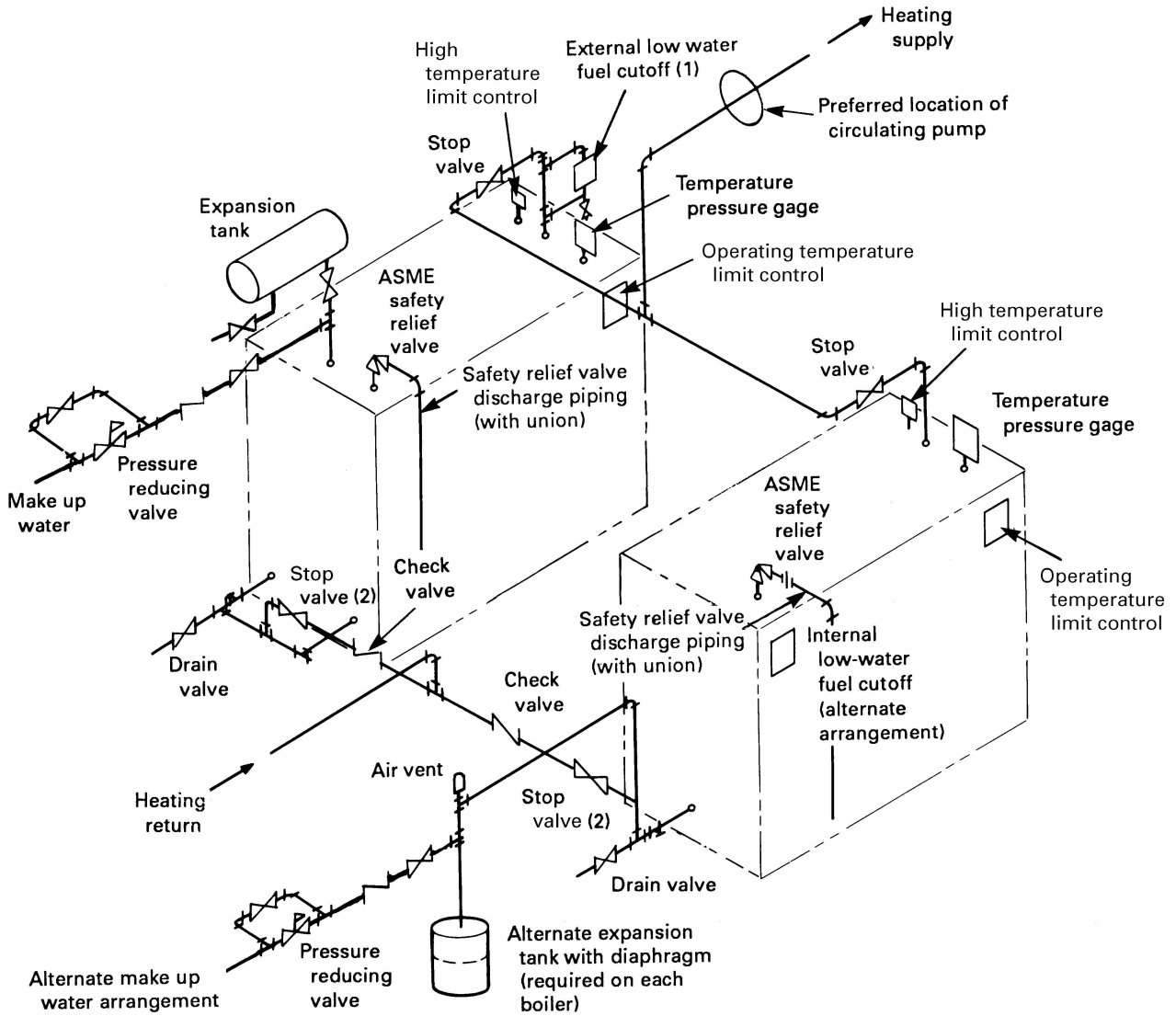

GENERAL NOTE: Plumbing codes may require the installation of a reduced pressure principle backflow preventer on a boiler when the makeup water source is from a potable water supply.

NOTES:

- (1) Recommended control. See [HG-614](#). Acceptable shutoff valves or cocks in the connecting piping may be installed for convenience of control testing and/or service.
- (2) The common return header stop valves may be located on either side of the check valves.

Table HG-709.2
Expansion Tank Capacities for Forced Hot Water
Systems

System Volume, gal (m ³)	Tank Capacities, gal (m ³)	
	Prepressurized Diaphragm Type	Nonpressurized Type
100 (0.38)	9 (0.034)	15 (0.057)
200 (0.76)	17 (0.064)	30 (0.114)
300 (1.14)	25 (0.095)	45 (0.170)
400 (1.51)	33 (0.125)	60 (0.227)
500 (1.89)	42 (0.159)	75 (0.284)
1,000 (3.79)	83 (0.314)	150 (0.568)
2,000 (7.57)	165 (0.625)	300 (1.136)

GENERAL NOTES:

- (a) The capacities in this Table are based on an average operating temperature of 195°F (90°C), a fill pressure of 12 psig, and a maximum operating pressure of 30 psig (200 kPa).
- (b) System volume includes volume of water in boiler, radiation, and piping, not including the expansion tank. Expansion tank capacities are based on an acceptance factor of 0.4027 for prepressurized types and 0.222 for nonprepressurized types. A procedure for estimating system volume and determining expansion tank sizes for other design conditions may be found in Chapter 12 of the 1996 HVAC Systems and Equipment Volume of the ASHRAE Handbook.

HG-709.1 Heating Systems With Open Expansion Tank. An indoor overflow from the upper portion of the expansion tank shall be provided in addition to an open vent, the indoor overflow to be carried within the building to a suitable plumbing fixture or the basement.

HG-709.2 Closed Heating Systems. An expansion tank shall be installed that will be consistent with the volume and capacity of the system. If the system is designed for a working pressure of 30 psi (200 kPa) or less, the tank shall be suitably designed for a minimum hydrostatic test pressure of 75 psi (520 kPa). Expansion tanks for systems designed to operate above 30 psi (200 kPa) shall be constructed in accordance with Section VIII, Division 1. Alternatively, a tank built to Section X requirements may be used if the pressure and temperature ratings of the tank are equal to or greater than the pressure and temperature ratings of the system. Provisions shall be made for draining the tank without emptying the system, except for prepressurized tanks.

The minimum capacity of the closed type expansion tank may be determined from [Table HG-709.2](#) or from the following formula where the necessary information is available:

(U.S. Customary Units)

$$V_t = [(0.00041T - 0.0466)V_s] / [(P_a/P_f) - (P_a/P_o)]$$

(SI Units)

$$V_t = [(0.000738T - 0.03348)V_s] / [(P_a/P_f) - (P_a/P_o)]$$

where

P_a = atmospheric pressure

P_f = fill pressure

P_o = maximum operating pressure

T = average operating temperature

V_s = volume of system, not including tanks

V_t = minimum volume of tanks

HG-709.3 Hot Water Supply Systems. If a system is equipped with a check valve or pressure reducing valve in the cold water inlet line, consideration should be given to the installation of an airtight expansion tank or other suitable air cushion. Otherwise, due to the thermal expansion of the water, the pressure relief valve may open periodically. If an expansion tank is provided, it shall be constructed in accordance with Section VIII, Division 1 or Section X. Except for prepressurized tanks, which should be installed on the cold water side, provisions shall be made for draining the tank without emptying the system. See [Figure HLW-809.1](#) for a typical acceptable installation.

HG-710 Stop Valves

HG-710.1 For Single Steam Boilers. When a stop valve is used in the supply pipe connection of a single steam boiler, there shall be one used in the return pipe connection.

HG-710.2 For Single Hot Water Heating Boilers. (23)

(a) Stop valves shall be located at an accessible point in the supply and return pipe connections as near the boiler nozzle as is convenient and practicable, of a single hot water heating boiler installation to permit draining the boiler without emptying the system.

(b) The stop valves required by (a) may be eliminated when the boiler can be drained without draining the system. Means to allow draining the boiler without emptying the system may include installation of the boiler above the system or isolation of the boiler from the system by equipment.

HG-710.3 For Multiple Boiler Installations. A stop valve shall be used in each supply and return pipe connection of two or more boilers connected to a

Table HG-715
Size of Bottom Blowoff Piping, Valves, and Cocks

Minimum Required Pressure Relief Valve Capacity, lb (kg) of steam/hr [Note (1)]	Blowoff Piping, Valves, and Cocks Min. Size, NPS (DN)
Up to 500 (225)	$\frac{3}{4}$ (20)
501 to 1,250 (225 to 550)	1 (25)
1,251 to 2,500 (550 to 1200)	1 $\frac{1}{4}$ (32)
2,501 to 6,000 (1200 to 2700)	1 $\frac{1}{2}$ (40)
6,001 (2700) and larger	2 (50)

NOTE: (1) To determine the discharge capacity of pressure relief valves in terms of Btu, multiply the relieving capacity in lb of steam/hr by 1,000.

common system. See Figures HG-703.1(a), HG-703.1(b), and HG-703.2.

(23) **HG-710.4 Type of Stop Valve(s).**

(a) All valves or cocks shall conform with the applicable portions of HF-203 and may be ferrous or nonferrous.

(b) The minimum pressure rating of all valves or cocks shall be at least equal to the pressure marked on the boiler, and the temperature rating of such valves or cocks, including all internal components, shall be not less than 250°F (120°C).

(c) Valves or cocks shall be flanged, threaded, or have ends suitable for welding or brazing.

(d) All valves or cocks with stems or spindles shall have adjustable-pressure-type packing glands or alternate design to prevent leakage through the stem, and all plug-type cocks shall be equipped with a guard or gland. The plug or other operating mechanism shall be distinctly marked in line with the passage to indicate whether it is opened or closed.

(e) All valves or cocks shall have tight closure when under boiler hydrostatic test pressure.

(23) **HG-715 Bottom Blowoff and Drain Valves**

(a) *Bottom Blowoff Valve.* Each steam boiler shall have a bottom blowoff connection fitted with a valve or cock connected to the lowest water space practicable with a minimum size as shown in Table HG-715. The discharge piping shall be full size to the point of discharge.

(b) Boilers having a capacity of 25 gal (95 L) or less are exempt from the above requirements, except that they must have an NPS $\frac{3}{4}$ (DN 20) minimum drain valve.

(c) *Drain Valve.* Each steam, hot water heating, or hot water supply boiler shall have one or more drain connections at the lowest practicable point on the boiler. A valve or cock shall be fitted to these drain connections or to the lowest point on piping connected to the boiler at these drain connections. The minimum size of the drain

piping, valves, and cocks shall be NPS $\frac{3}{4}$ (DN 20). The discharge piping shall be full size to the point of discharge. When the blowoff connection is located at the lowest water containing space, a separate drain connection is not required.

(d) *Minimum Pressure Rating.* The minimum pressure rating of valves and cocks used for blowoff or drain purposes shall be at least equal to the MAWP marked on the boiler, but in no case shall it be less than 30 psi (200 kPa). The temperature rating of such valves and cocks shall not be less than 250°F (120°C).

HG-720 Setting

Boilers of wrought materials of the wet-bottom type having an external width of over 36 in. (900 mm) shall have not less than 12 in. (300 mm) between the bottom of the boiler and the floorline, with access for inspection. When the width is 36 in. (900 mm) or less, the distance between the bottom of the boiler and the floorline shall be not less than 6 in. (150 mm), except that, when any part of the wet bottom is not farther from an outer edge than 12 in. (300 mm), this distance shall be not less than 4 in. (100 mm).

HG-725 Methods of Support

HG-725.1 Loadings.

(a) The design and attachment of lugs, hangers, saddles, and other supports shall take into account the stresses due to hydrostatic head in determining the minimum thicknesses required. Additional stresses imposed by effects other than working pressure or static head, which increase the average stress by more than 10% of the allowable working stress, shall also be taken into account. These effects include the weight of the component and its contents, and the method of support.

(b) In applying the requirements of (a) above, localized stresses due to concentrated support loads, temperature changes, and restraint against dilation of the boiler due to pressure shall be provided for. Lugs, hangers, brackets, saddles, and pads shall conform satisfactorily to the shape of the shell or surface to which they are attached or are in contact.

HG-725.2 Boilers Over 72 in. (1800 mm) in Diameter. A horizontal-return tubular boiler over 72 in. (1800 mm) in diameter shall be supported from steel hangers by the outside-suspension type of setting, independent of the furnace wall. The hangers shall be so designed that the load is properly distributed.

HG-725.3 Boilers Over 54 in. (1400 mm). up to 72 in. (1800 mm) in Diameter. A horizontal-return tubular boiler over 54 in. (1400 mm) and up to and

Figure HG-725(a)
Spacing and Weld Details for Supporting Lugs in Pairs on Horizontal-Return Tubular Boiler

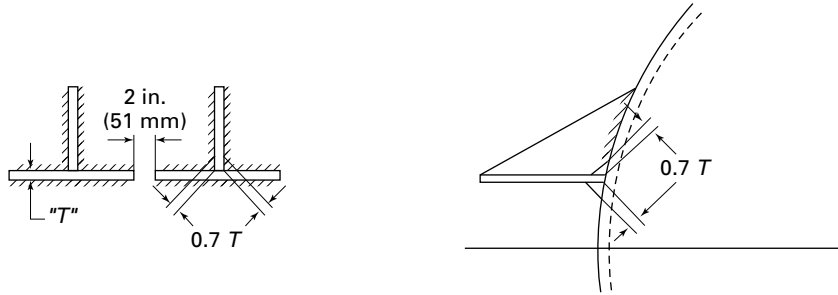

GENERAL NOTE: T = not less than 1% of the boiler diameter.

including 72 in. (1800 mm) in diameter shall be supported by the outside-suspension type of setting, or at four points by not less than eight steel brackets set in pairs, the brackets of each pair to be spaced not over 2 in. (50 mm) apart and the load to be equalized between them. [see Figure HG-725(a).]

HG-725.4 Boilers up to 54 in. (1400 mm) in Diameter. A horizontal-return tubular boiler up to and including 54 in. (1400 mm) in diameter shall be supported by the outside-suspension type of setting, or by not less than two steel brackets on each side.

HG-725.5 Supporting Members. If the boiler is supported by structural steel work, the steel supporting members shall be so located or insulated that the heat from the furnace cannot impair their strength.

HG-725.6 Lugs or Hangers. Lugs, hangers, or brackets made of materials in accordance with the Code requirements may be attached by fusion welding provided they are attached by fillet welds along the entire periphery or contact edges. Figure HG-725(b) illustrates an acceptable design of hanger bracket. The bracket plates shall be spaced at least $2\frac{1}{2}$ in. (64 mm) apart, but this dimension shall be increased if necessary to permit access for the welding operation. The stresses computed by dividing the total load on each lug, hanger, or bracket, by the minimum cross-sectional area of the weld shall not exceed 2800 psi (19 MPa). Where it is impractical to attach lugs, hangers, or brackets by welding, studs with not less than 10 threads/in. (approx. 4 threads/cm) may be used. In computing the shearing stresses, the root area at the bottom of the thread shall be used. The shearing and crushing stresses on studs shall not exceed 8% of the

Figure HG-725(b)
Welded Bracket Connection for Horizontal-Return Tubular Boiler

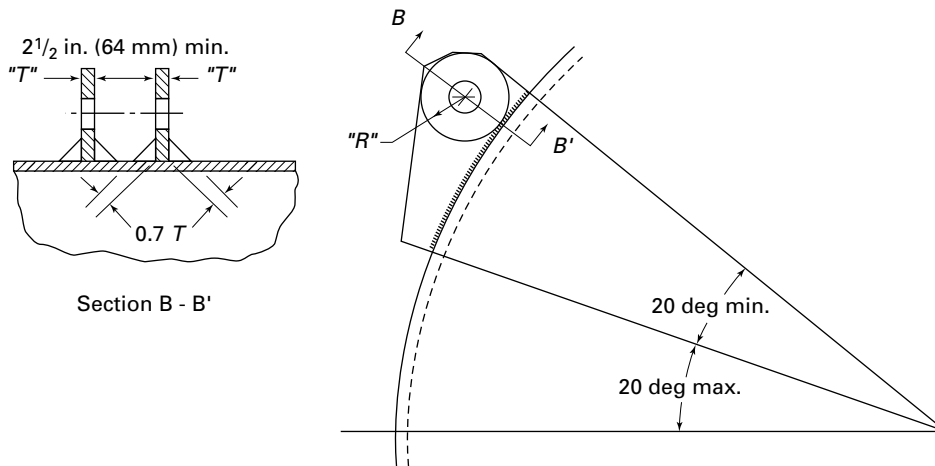

GENERAL NOTE: R = not less than $1\frac{1}{2} \times$ diameter of hole; T = not less than 1% of the boiler diameter.

strength given in Section II, Part D, Table 6A for bolting materials.

HG-725.7 Settings. Boilers of wrought materials of the wet-bottom type having an external width of over 36 in. (900 mm) shall be supported so as to have a minimum clearance of 12 in. (300 mm), between the bottom of the boiler and the floor, to facilitate inspection. When the width is 36 in. (900 mm) or less, the clearance

between the bottom of the boiler and the floorline shall be not less than 6 in. (150 mm), except when any part of the wet bottom is not farther from the outer edge than 12 in. (300 mm). This clearance shall be not less than 4 in. (100 mm). Boiler insulation, saddles, or other supports shall be arranged so that inspection openings are readily accessible.

ARTICLE 8

MODULAR BOILERS

HG-800 INSPECTION AND ACCESS OPENINGS

Modular boilers that are installed side by side, front to back, or by stacking in accordance with the Manufacturer's recommendations shall have their inspection openings located so that they are accessible.

(23) **HG-801 MARKING AND CERTIFICATION OF MODULAR BOILERS AND USE OF MANUFACTURER'S MODULAR MASTER DATA REPORTS**

Modular boilers shall be marked and certified using one of the following methods:

(a) Multiple individual marked and certified boilers are combined as follows:

(1) Individual boilers that are not constructed primarily of cast iron or cast aluminum shall have their own markings applied directly on the boilers per the requirements of [HG-530.1](#). Each individual boiler shall have its own Manufacturer's Master Data Report or Manufacturer's Data Report per the requirements of [HG-520.1](#). [Form H-2](#) or [Form H-3](#) shall be used.

(2) Individual boilers constructed primarily of cast iron or cast aluminum shall have their own markings applied per the requirements of [HG-530.2](#).

(3) The common supply and return headers are exempt from Section IV requirements.

(4) The Manufacturer's Modular Master Data report shall summarize specific information for each boiler, including the applicable Manufacturer's Data Reports. [Form H-1](#) shall be used.

(b) Multiple individual unmarked modules are combined and certified as a complete modular boiler as follows:

(1) The assembled modular boiler shall have a single nameplate per the requirements of [HG-530](#) and a Manufacturer's Modular Master Data Report.

(2) Individual modules not constructed primarily of cast iron or cast aluminum shall bear the manufacturer's name and be permanently identified using one of the methods described in [HG-530.1\(b\)](#) in a manner traceable to the modular boiler nameplate and Manufacturer's Master Data Report or Manufacturer's Data Report per the requirements of [HG-520.1](#). [Form H-2](#) or [Form H-3](#) shall be used.

(3) The supply and return headers shall be constructed in accordance with Section IV and recorded on the Manufacturer's Data Report. [Form H-2](#) or [Form H-3](#) shall be used.

(4) The aggregate heating surface of all the modules and the combined minimum pressure relief valve capacity shall be marked on the nameplate.

(5) The Manufacturer's Modular Master Data Report shall summarize specific information for each module, including the applicable Manufacturer's Data Reports. [Form H-1](#) shall be used.

HG-802 INSTRUMENTS, FITTINGS, AND CONTROLS

HG-802.1 Modular Steam Heating Boilers.

(a) Each individual boiler of a modular steam heating boiler shall be equipped with

(1) a steam gage (see [HG-602](#))

(2) a water gage glass (see [HG-603](#))

(3) a pressure control that will cut off the fuel supply when the pressure reaches an operating limit, which shall be less than the maximum allowable pressure [see [HG-605\(b\)](#)]

(4) a low-water cutoff (see [HG-606](#))

(b) The assembled modular steam boiler shall also be equipped with a safety limit control that will cut off the fuel supply to prevent steam pressure from exceeding the 15-psi (100-kPa) maximum allowable working pressure of the boiler. The control shall be constructed to prevent a pressure setting above 15 psi (100 kPa) [see [HG-605\(a\)](#)].

(c) When the assembled steam heating boiler is certified as a single boiler in accordance with [HG-801\(b\)](#), the boiler assembly shall be equipped with

(1) a steam gage, which may be located on the supply header (see [HG-602](#)).

(2) a water gage glass (see [HG-603](#)).

(3) a pressure control that will cut off the fuel supply when the pressure reaches an operating limit, which shall be less than the maximum allowable pressure [see [HG-605\(b\)](#)].

(4) a low-water cutoff (see [HG-606](#)).

(5) a safety limit control that will cut off the fuel supply to prevent steam pressure from exceeding the 15-psi (100-kPa) maximum allowable working pressure

of the boiler. The control shall be constructed to prevent a pressure setting above 15 psi (100 kPa) [see HG-605(a)].

HG-802.2 Modular Hot Water Heating and Hot Water Supply Boilers.

(a) Each individual boiler of a modular hot water heating or hot water supply boiler shall be equipped with

(1) a pressure or altitude gage (see HG-611)

(2) a thermometer (see HG-612)

(3) a temperature control that will cut off the fuel supply when the temperature reaches an operating limit, which shall be less than the maximum allowable temperature [see HG-613(b)]

(b) The assembled modular hot water heating or hot water supply boiler shall also be equipped with

(1) a safety limit control that will cut off the fuel supply to prevent the water temperature from exceeding the maximum allowable temperature at the boiler outlet. The control shall be constructed to prevent a temperature setting above the maximum. This control shall be located within 3 ft (1 m) of the fitting connecting the last boiler to the supply piping [see HG-613(a)].

(2) a low-water fuel cutoff (see HG-614).

(c) When the assembled hot water heating or hot water supply boiler is certified as a single boiler in accordance with HG-801(b), the boiler assembly shall be equipped with

(1) a pressure or altitude gage, which may be located on the supply header (see HG-611).

(2) a thermometer, which may be located in the supply header (see HG-612).

(3) a temperature control that will cut off the fuel supply when the temperature reaches an operating limit, which shall be less than the maximum allowable temperature [see HG-613(b)].

(4) a safety limit control that will cut off the fuel supply to prevent the water temperature from exceeding the maximum allowable temperature at the boiler outlet. The control shall be constructed to prevent a temperature setting above the maximum. This control shall be located within 3 ft (1 m) of the fitting connecting the last module to the supply piping [see HG-613(a)].

(5) a low-water fuel cutoff (see HG-614).

(b) The stop valves required by (a) may be eliminated when the modular boiler can be drained without draining the system. Means to allow draining the modular boiler without emptying the system may include locating the modular boiler above the system or isolating the modular boiler from the system by equipment.

(c) Flow control valves and circulating pumps may be located in the return line of each boiler.

(d) Modular boilers that are installed side by side, front to back, or by stacking in accordance with the Manufacturer's recommendations shall have their nameplate marking located to provide access for inspection in the assembled position.

HG-803.2 Modular Steam Heating Boilers.

(a) Each individual boiler of a modular steam heating boiler shall be equipped with

(1) a safety valve (see HG-701)

(2) a blowoff valve [see HG-715(a)]

(3) a drain valve [see HG-715(c)]

(b) The assembled modular steam heating boiler shall also be equipped with

(1) a feedwater connection [see HG-705(a)]

(2) a return pipe connection (see HG-703.2)

(c) When the assembled modular steam heating boiler is certified as a single boiler in accordance with HG-801(b), it shall be equipped with

(1) one or more safety valves, which may be located on the supply header (see HG-701)

(2) a blowoff valve [see HG-715(a)]

(3) one or more drain valves, which may be located in the return header or piping connected to the boiler provided the arrangement of the modules is such as to allow the drain valve or valves to drain the entire modular boiler [see HG-715(c)]

(4) a feedwater connection [see HG-705(a)]

(5) a return pipe connection (see HG-703.2)

HG-803.3 Modular Hot Water Heating and Hot Water Supply Boilers.

(a) Each boiler of a modular hot water heating or hot water supply boiler shall be equipped with

(1) one or more safety relief valves (see HG-701)

(2) a drain valve [see HG-715(c)]

(b) The assembled modular hot water heating or hot water supply boiler shall also be equipped with

(1) a makeup water connection [see HG-705(b)]

(2) a provision for thermal expansion (see HG-709)

(c) When the assembled modular hot water heating or hot water supply boiler is certified as a single boiler in accordance with HG-801(b), it shall be equipped with

(1) one or more safety relief valves, which may be located on the supply header (see HG-701)

(23) HG-803 INSTALLATION REQUIREMENTS

HG-803.1 Modular Boilers.

(a) The individual boiler modules shall be manifolded together without intervening valves between modules and shall be provided with a single set of stop valves on the common supply and return headers.

(2) one or more drain valves, which may be located in the return header or piping connected to the boiler provided the arrangement of the modules is such as to

allow the drain valve or valves to drain the entire modular boiler [see [HG-715\(c\)](#)]

(3) a makeup water connection [see [HG-705\(b\)](#)]

(4) a provision for thermal expansion (see [HG-709](#))

PART HF REQUIREMENTS FOR BOILERS CONSTRUCTED OF WROUGHT MATERIALS

ARTICLE 1 GENERAL

HF-100 SCOPE

The rules in [Part HF](#) are applicable to heating boilers that are constructed primarily of wrought materials, and shall be used in conjunction with general requirements of [Part HG](#) of this Section.

ARTICLE 2

MATERIAL REQUIREMENTS

HF-200 GENERAL MATERIAL REQUIREMENTS

Materials other than those described herein may not be used, unless approved by the Boiler and Pressure Vessel Committee in accordance with Section II, Part D, Mandatory Appendix 5.

(23) HF-201 PLATE

(a) Plate used in the construction of pressure-containing parts shall conform to one of the specifications given in Section II for which allowable stress values are given in Section II, Part D, Table 6A or Table 6B except as otherwise provided in [HF-203](#) and [HF-205](#).

(b) Stainless plates of SA-240 for which allowable stress values are given in Section II, Part D, Table 6A may be used in the construction of hot water heating boilers provided the following are met:

(1) The water temperature shall not exceed 210°F (99°C) as indicated in Section II, Part D, Table 6A, Note G9.

(2) The material shall be fully annealed.

(c) For pressure-retaining plate material, a material test report is required to verify that the chemical and mechanical properties are within the permissible range listed in Section II.

HF-202 RODS, BARS, AND SHAPES

Rods, bars, and shapes may be used in boiler construction for pressure parts such as flange rings, stiffening rings, braces, frames for reinforced openings, stays and staybolts, and similar parts. Rods, bars, and shapes used for pressure parts shall conform to one of the specifications in Section II and shall be limited to those listed in Section II, Part D, Table 6A or Table 6B except as otherwise provided in [HF-203](#) and [HF-205](#).

(23) HF-203 PREFABRICATED OR PREFORMED PRESSURE PARTS

Prefabricated or preformed pressure parts for boilers that are subject to allowable working stresses due to internal or external pressure in the boilers and that are furnished by other than the shop of the manufacturer responsible for the completed boilers shall conform to all applicable requirements of the Code as related to a

completed boiler, including inspection in the shop of the parts manufacturer and the furnishing of Manufacturer's Partial Data Reports except as permitted in [HF-203.1](#), [HF-203.2](#), and [HF-203.3](#).

HF-203.1 Cast, Forged, Rolled, or Die-Formed Standard Pressure Parts. (23)

(a) Pressure parts such as pipe fittings, valves, flanges, nozzles, welding necks, welding caps, manhole frames and covers, and casings of pumps that are part of a boiler circulating system that are wholly formed by casting, forging, or die forming shall not require inspection, mill test reports or Manufacturer's Partial Data Reports. Standard pressure parts that comply with some ASME standard¹⁸ shall be made of materials listed in the ASME Code-accepted standard covering the particular type of pressure part. Standard pressure parts that comply with a Manufacturer's standard¹⁹ shall be made of materials permitted under Section II. Such parts shall be marked with the name or trademark of the manufacturer and such other markings as are required by the several standards. Such markings shall be considered as the manufacturer's certification that the product complies with the material specifications and standards indicated and is suitable for service at the rating indicated. The intent of the paragraph will have been met if, in lieu of the detailed marking on the part itself, the parts described herein have been marked in any permanent or temporary manner that will serve to identify the part with the manufacturer's written listing of the particular items and such listings are available for examination by the Inspector.

(b) Parts of small size falling within this category for which it is difficult or impossible to obtain identified material or that may be stocked and for which mill test reports or certificates cannot be economically obtained and are not customarily furnished, and that do not appreciably affect the safety of the vessel, may be used for relatively unimportant parts or parts stressed to not more than 50% of the stress value permitted by the Code provided they are suitable for the purpose intended and are accepted by the Inspector [see (a)]. The manufacturer of the completed vessel shall satisfy himself that the part is suitable for the design conditions specified for the completed vessel.

HF-203.2 Cast, Forged, Rolled, or Die-Formed Nonstandard Pressure Parts. Pressure parts such as shells, heads, removable cover plates, and pipe coils that are attached to other wrought parts and that are wholly formed by casting, forging, rolling, or die forming may be supplied basically as materials. All such parts shall be made of materials permitted under Section II and the manufacturer of the part shall furnish mill test reports or other acceptable evidence to that effect. Such parts shall be marked with the name or trademark of the manufacturer and with such other markings as will serve to identify the particular parts with accompanying material identification. The manufacturer of the completed boiler shall satisfy himself that the part is suitable for the design conditions specified for the completed boiler in accordance with the rules of this Section.

(23) **HF-203.3 Welded Standard Pressure Parts for Use Other Than the Shell of a Boiler.**²⁰

(a) Pressure parts such as pipe fittings, nozzles, welding necks, welding caps, valves, and flanges that are fabricated by one of the welding processes recognized by the Code shall not require inspection, mill test reports, or Manufacturer's Partial Data Reports provided

(1) all such parts are made of materials permitted under Section II or in a Code-accepted standard

(2) if arc or gas welded, the welding complies with the rules of this Section

(b) Such parts shall be marked with the name or trademark of the manufacturer and with such other markings as will serve to identify the materials of which the parts are made. Such markings shall be considered as the manufacturer's certification that the product complies with (a)(1). A statement by the parts manufacturer that all welding complies with Code requirements shall be accepted as evidence that the product complies with (a)(2).

HF-204 PIPE AND TUBES

Pipe and tubes of seamless or welded construction shall conform to one of the specifications given in Section II for which allowable stress values are given in Section II, Part D, Table 6A or Table 6B except as otherwise provided in HF-203 and HF-205 when used in the construction of pressure-containing parts.

HF-204.1 Integrally Finned Tubes. Integrally finned tubes may be made from tubes that conform in every respect with one of the specifications given in Section II, except that the pressure test is not required for nonferrous tubes. These tubes may be used under the following conditions.

(a) The tubes after finning shall have a temper or condition that conforms to one of those provided in the governing specifications.

(b) The maximum allowable stress value for the finned tube shall be that given in Section II, Part D, Table 6A or Table 6B for the tube before finning, except as permitted in (c) below.

(c) The maximum allowable stress value for a temper or condition that has a higher stress value than that of the tube before finning may be used provided that qualifying tensile tests demonstrate that such a temper or condition is obtained. The stress values used shall not exceed those shown in Section II, Part D, Table 6A or Table 6B for the temper or condition involved. The qualifying tensile tests shall be made on specimens of finned tube from which the fins have been removed by machining.

(d) The maximum allowable internal or external design pressure of the tube shall be based on either the minimum wall thickness of the finned section or of the unfinned section, whichever is smaller.

(e) In addition to the tests required by the governing specifications (except for pressure tests for nonferrous tubes), each tube after finning shall withstand without evidence of leakage an internal pneumatic test of not less than 250 psi (1720 kPa) for 5 sec. The test method used shall permit easy visual detection of any leakage, such as immersion of the tube under water or a pressure differential method.²¹ A test meeting the requirements of HG-510(c) may be substituted for this requirement if the boiler design so permits.

HF-204.2 Electric Resistance Welded Fin Tubes.

Tubes with electric resistance welded fins that serve as extended heating surface and have no load-carrying function may be supplied as materials. A Code Certificate Holder need not perform the welds attaching the fins. When the welding process attaching the fins is automatic, welding procedure and performance qualification testing is not required.

HF-204.4 Laser-Welded Fin Tubes. Tubes with laser-welded fins that serve as extended heating surfaces may be supplied as materials under the following conditions: (Welding of the fins to the tube need not be performed by a Code Certificate Holder.)

(a) The tube material shall be a material meeting the requirements for heat exchanger tubing set forth in this Section.

(b) The heat transfer fin material shall be a material that is suitable for the service conditions. The fin material need not conform to a permitted SA specification, but it shall be identified to a published material specification and be suitable for welding to the tube.

(c) The fin shall be attached to form a tee with the tube wall without the addition of filler metal by automatic laser beam welding.

(d) The fin shall not be considered to provide any support to the tube for either pressure loading or external loading.

(e) Welding shall be done following a Welding Procedure Specification (WPS) that documents the following and has been qualified in accordance with (f). The WPS shall be requalified for any change as described in the following variables:

(1) a change in the type of welding equipment (e.g., YAG, CO₂, etc.)

(2) a change in the nominal diameter or thickness of the tube or in the nominal thickness of the fin

(3) a change in the specification or grade of the fin material

(4) the deletion or a change in the composition of the shielding gas, backing gas, trailing gas, or plasma-removing gas

(5) a decrease of more than 10% in the flow rate of the shielding gas, backing gas, trailing gas, or plasma-removing gas

(6) a change in the optical technique used to focus the welding energy

(7) a change of more than 10% in the travel speed, the ratio of beam diameter to focal length, or the lens-to-work distance

(8) a change of more than 10% in the angle of the beam relative to the major axis of the tube

(9) a change of more than 10% in beam oscillation width, frequency, or dwell time

(10) a change of more than 10% in the beam-pulsing frequency and pulse duration

(11) a decrease of more than 10% in the power delivered to the work surface as measured by calorimetric or other suitable means

(f) Procedure qualification shall consist of metallographic examination at a magnification of 10× of three cross-sections taken at locations separated by not less than 3 ft (1 m) along the length of a tube. The welds shall be free of cracks, and penetration of the weld into the tube wall shall not exceed 20% of the tube wall thickness.

(g) Qualification of welding operators is not required.

(h) Production sampling consisting of one cross-section shall be examined as described in (f) for procedure qualification anytime there is a change in the nominal diameter or thickness of the tube or a change in the nominal thickness of the fin.

HF-205 MATERIAL NOT FULLY IDENTIFIED

Material that has lost its identity with a permitted specification may be accepted provided that it satisfies the conditions given in either HF-205.1 or HF-205.2.

HF-205.1 Acceptance by Authentic Test Record and Marking. Each piece shall be shown to have chemical requirements and mechanical properties within the permissible range of the permitted specification in Section II by an authentic test record and by marking identifying it with that record. When the permitted specifica-

tion requires other tests or more restrictive tests than those of the specification covered by the authentic test record, the material shall be subjected to sufficient additional tests to satisfy the Inspector that it complies with the permitted specification.

HF-205.2 Acceptance by Testing.

(a) *Plate.* The chemical check analyses and mechanical tests of plates shall be made as required in the permitted specification with the following modifications. The carbon and manganese contents shall be determined in all check analyses. The Inspector shall decide whether these contents are acceptable when the permitted specification does not specify carbon and manganese limits. When the direction of rolling is not definitely known, two tension specimens shall be taken at right angles to each other from a corner of each plate, and two bend specimens shall be taken from the middle of adjacent sides of each plate. One tension specimen and both bend specimens shall meet the permitted specification requirements.

(b) *Tubes and Pipe.* Each length of tube or pipe shall be subjected to a chemical check analysis and sufficient mechanical tests to satisfy the Inspector that all the material is identified with a given heat or heat treatment lot and that the material complies with the chemical and mechanical requirements of the permitted specification. Material specified as suitable for welding, cold bending, close coiling, and similar operations shall be given sufficient check tests to satisfy the Inspector that it is suitable for the fabrication procedure to be used.

(c) *Rods, Bars, and Shapes.* Each length of rods shall be subjected to a chemical check analysis and sufficient mechanical tests to satisfy the Inspector that all the material is identified with a given heat or heat treatment lot, and that the material complies with the chemical and mechanical requirements of the permitted specification. Material specified as suitable for welding, cold bending, and similar operations shall be given check tests to satisfy the Inspector that it is suitable for the fabrication procedure to be used.

HF-205.3 Marking and Report on Tests of Nonidentified Material.

When the identity of the material with the permitted specification has been established in accordance with HF-205.1 or HF-205.2, each piece of material (except as alternatively provided in the specification for tubes, pipe, rods, bars, or shapes) shall be marked to the satisfaction of the Inspector by the boiler manufacturer or the testing agency, with a marking giving the permitted specification number and grade or type and a serial S-number identifying the particular lot of material. A suitable report, clearly marked as being a "Report on Tests of Nonidentified Material," shall be furnished, properly filled out and certified by the boiler manufacturer or testing agency, and this report, when

accepted by the Inspector, shall constitute authority to use the material.

HF-206 RECERTIFICATION OF MATERIAL PRODUCED TO A SPECIFICATION NOT PERMITTED BY THIS SECTION

A particular production lot of material may be recertified to a permitted specification by the boiler or part manufacturer under the following conditions.

(a) The specification to which the material was produced, processed, and purchased must be available for comparison to the permitted specification.

(b) A test report from the material manufacturer must be available.

(c) The material must have marking, acceptable to the Inspector, for identification to the test report.

(d) The test report must show that all chemical and mechanical properties of the lot comply with the requirements of the permitted specification.

(e) When conformance of the lot to the permitted specification has been established, it may be accepted and marked, as required by the permitted specification, by the boiler or part manufacturer.

HF-207 AUSTENITIC STAINLESS STEEL

Austenitic alloys are subject to stress corrosion cracking, intergranular attack, pitting, and crevice corrosion. Factors that affect the susceptibility of these materials are applied or residual stress, water chemistry and deposition of solids, and material condition. Susceptibility to attack is enhanced when the material is used in a sensitized condition or with residual cold work. Concentration of corrosive agents (e.g., chlorides, caustic or reduced sulfur species) can occur under deposits formed on the surface of these materials and can result in severe

under deposit wasting or cracking. Refer to Section II, Part D, Nonmandatory Appendix A, A-300 for detailed guidance and recommendations.

The following preventive measures should be considered in designs utilizing these materials, along with Section II-D, Nonmandatory Appendix A:

(a) Careful selection of materials for the specific application. For welded applications, low carbon grades or titanium-stabilized grades should be considered.

(b) Proper consideration of fabrication methods and techniques to reduce residual stresses and sites for crevice corrosion. Cold working, grinding, bending, and high-heat input welding should be minimized. In the design of the boiler, stagnant fluid regions should be avoided, as should crevices. Weld joints should be designed to avoid integral back-up rings or back-up bars that are left in place and create a crevice.

(c) Control of boiler water chemistry and avoidance of other environmental sources of chlorides, such as chloride containing insulation or swimming pool environments.

HF-210 MAINTAINING MATERIAL IDENTIFICATION

(a) Material for pressure parts shall carry identification markings as required by the applicable material specification. If the original identification markings are cut out or the material is divided into two or more parts, the marking shall either be accurately transferred prior to cutting or a coded method of identification shall be used to assure identification of each piece of material during subsequent fabrication.

(b) Materials may be identified by any method suitable to the Inspector, provided the method used does not result in sharp discontinuities and identifies the material until the boiler is completed.

ARTICLE 3

DESIGN STRESSES AND MINIMUM THICKNESSES

HF-300 MAXIMUM ALLOWABLE STRESS VALUES

Section II, Part D, Tables 6A and 6B give the maximum allowable stress values indicated for ferrous and nonferrous materials, respectively, conforming to the specifications listed therein.

HF-301 MINIMUM THICKNESSES²²

(23) **HF-301.1 Ferrous Plates.**

(a) Except as noted in (b) through (d), the minimum thickness of any ferrous plate, or pipe used in lieu of plate, under any pressure shall be $\frac{3}{32}$ in. (2.5 mm).

(b) Plates that will be exposed to primary furnace gases shall be not less than $\frac{3}{16}$ in. (5 mm).

(c) Alloy steel plates listed in Section II, Part D, Table 6A with thicknesses less than those permitted by (a) and (b) may be used when the following requirements are met:

(1) The material thickness of plates that will be exposed to primary furnace gases shall be not less than $\frac{3}{32}$ in. (2.5 mm).

(2) The material thickness of secondary flue gas heat exchanger surfaces shall be not less than 0.0394 in. (1 mm).

(d) The minimum thickness of any tubesheet with tubes installed by expanding shall be $\frac{1}{4}$ in. (6 mm).

(23) **HF-301.2 Nonferrous Plates.**

(a) The minimum thickness of any nonferrous plate under pressure shall be $\frac{3}{32}$ in. (2.5 mm).

(b) The minimum thickness of any nonferrous tubesheet with tubes installed by expanding shall be $\frac{5}{16}$ in. (8 mm).

HF-302 BASIS FOR ESTABLISHING STRESS VALUES IN SECTION II, PART D, TABLE 6A OR TABLE 6B

(a) In the determination of allowable stress values for pressure parts, the Committee is guided by successful experience in service, insofar as evidence of satisfactory performance is available. Such evidence is considered equivalent to test data where operating conditions are known with reasonable certainty. In the evaluation of new materials, it is necessary to be guided to a certain extent by the comparison of test information with similar data on successful applications of similar materials.

(b) At any temperature below the creep range, the allowable stresses are established at no higher than the lowest of the following:

(1) $\frac{1}{5}$ of the specified minimum tensile strength at room temperature

(2) $\frac{1}{5}$ of the tensile strength at temperature

(3) $\frac{2}{3}$ of the specified minimum yield strength at room temperature

(4) $\frac{2}{3}$ of the yield strength at temperature

(c) For bolting materials, the basis for setting stresses is the same as for all other materials with the exception that (1) and (2) above are

(1) $\frac{1}{4}$ of the specified minimum tensile strength at room temperature, and

(2) $\frac{1}{4}$ of the tensile strength at temperature

The following limitation also applies to bolting materials: at temperatures below the creep range, the stresses for materials whose strength has been enhanced by heat treatment or by strain hardening shall not exceed the lesser of 20% of the specified minimum tensile strength at room temperature or 25% of the specified minimum yield strength at room temperature unless these values are lower than the annealed values, in which case the annealed values shall be used.

PART HF — SUBPART HW REQUIREMENTS FOR BOILERS FABRICATED BY WELDING

ARTICLE 4 GENERAL REQUIREMENTS

HW-400 SCOPE

The requirements of this [Subpart HW](#) are applicable to boilers and parts thereof that are fabricated by welding.

HW-401 RESPONSIBILITY OF MANUFACTURER OR CONTRACTOR

Each manufacturer or contractor is responsible for the welding done by his organization and shall establish the procedures and conduct the tests required in Section IX to qualify the welding procedures he uses in the construction

of the weldments built under Section IV and the performance tests of welders and welding operators who apply these procedures.

It should be noted that the use of standard welding procedures is acceptable. All requirements for the use of these procedures shall be in accordance with Section IX. The use of these procedures shall be addressed in the manufacturer's or contractor's Quality Control Manual and shall be available for review by the Authorized Inspector.

ARTICLE 5

MATERIAL REQUIREMENTS

HW-500 PERMISSIBLE MATERIALS

Materials used in welded construction of pressure parts shall conform to one of the specifications given in Section II and shall be limited to those for which allowable stress values are given in Section II, Part D, Table 6A or Table 6B and for which weld group P-Numbers are assigned in Section IX.

(a) Carbon or alloy steel having a carbon content of more than 0.35% shall not be used in welded construction or be shaped by oxygen cutting or other thermal cutting processes.

(b) Stud material for arc stud welding and resistance stud welding of carbon steel shall be low carbon steel of an acceptable material in this Section and with a carbon maximum of 0.27% and with a minimum tensile strength of 60,000 psi (400 MPa). See further limits in [HW-730.4](#) and [HW-820](#).

(c) Materials joined by the inertia and continuous drive friction welding processes shall be limited to materials assigned P-Numbers in Section IX and shall not include rimmed or semikilled steel.

HW-501 MATERIALS OF DIFFERENT SPECIFICATIONS

Two materials of different specifications may be joined by welding provided the requirements of QW-251.2 of Section IX are met.

HW-502 MATERIALS FOR SMALL PARTS

Small parts used in welded construction under the provisions of [HF-203.1](#) shall be of good weldable quality.

ARTICLE 6

WELDING PROCESSES AND QUALIFICATIONS

HW-600 WELDING PROCESSES

The welding processes that may be used under this Part shall meet all the requirements of Section IX and are restricted to the following:

(a) arc or gas welding processes are restricted to shielded metal arc, submerged arc, gas metal arc, gas tungsten arc, plasma arc, atomic hydrogen metal arc, laser beam, electronic beam, and oxyfuel gas welding

(b) pressure welding processes are restricted to flash, induction, resistance, pressure thermit, pressure gas, and inertia and continuous drive friction welding

(c) definitions are given in Section IX that include variations of these processes

HW-610 WELDING QUALIFICATIONS

Unless specified otherwise for a particular process, the procedures, the welders, and the welding operators used in welding pressure parts and in joining nonpressure parts (attachments) to pressure parts shall be qualified in accordance with Section IX. When the welding process attaching non-pressure parts that have essentially no load-carrying function (such as extended heat transfer surfaces) is automatic, procedure and performance qualification testing is not required.

HW-611 NO PRODUCTION WORK WITHOUT QUALIFICATIONS

No production work shall be undertaken until the procedures, the welders, and the welding operators have been qualified, except that performance qualification

by radiography, in conformance with Section IX, QW-304 for welders or QW-305 for welding operators, may be performed within the first 3 ft (1 m) of the first production weld.

HW-612 INTERCHANGE OF QUALIFYING TESTS AMONG MANUFACTURERS PROHIBITED

The performance qualification tests for welders and welding operators conducted by one manufacturer or contractor shall not qualify a welder or welding operator to do work for any other manufacturer or contractor.

HW-613 MAINTENANCE OF RECORDS OF QUALIFICATIONS AND IDENTIFYING MARKS

The Manufacturer or contractor shall maintain qualification records of the welding procedures, welders, and welding operators employed by him showing the date and results of test and the identification mark assigned to each welder. These records shall be certified to by the Manufacturer or contractor by signature or some other method of control in accordance with the Manufacturer's quality control system, and be accessible to the Inspector. The welder or welding operator shall stamp his identification mark on or adjacent to all welded joints made by him at intervals of not greater than 3 ft (1 m), or the Manufacturer shall keep a record of the welded joints on a vessel and the welders and welding operators used in making the joints.

ARTICLE 7

DESIGN OF WELDMENTS

HW-700 DESIGN OF WELDED JOINTS

HW-701 General Requirements

All welds, fillet or full penetration, shall be made to a qualified welding procedure by qualified welders for each welding process employed (manual, semiautomatic, automatic), in accordance with the applicable provisions of Section IX to assure satisfactory penetration and fusion into the base metal to the root of the weld. All members, prior to being welded, shall be properly fitted, aligned, and retained in position in accordance with the procedure specification for the welding procedure to be used.

HW-701.1 Butt Joints. Longitudinal, circumferential, and other joints uniting plates of a drum, shell, or other pressure parts, except as provided in [HW-701.1](#), [HW-701.2](#), [HW-701.3](#), [HW-710](#), [HW-711](#), and [HW-712](#), shall be butt joints. A butt joint shall be double-welded butt or may have filler metal added from one side only, provided the weld penetration is complete and there is reinforcement on both sides of the joint. There shall be no valley either on the edge or in the center of the joint and the weld shall be so built up that the weld metal shall present a gradual increase in thickness from the surface of the plate to the center of the weld. At no point shall the plate on one side of the joint be offset with the plate on the other side of joint in excess of the alignment tolerance in [HW-812](#) except as provided in [HW-715\(a\)\(2\)](#).

(a) A tapered transition section having a length not less than three times the offset between the adjoining surfaces as shown in [Figure HW-701.1](#), shall be provided at joints between materials that differ in thickness by more than one-fourth of the thickness of the thinner material or by more than $\frac{1}{8}$ in. (3.0 mm). The transition section may be formed by any process that will provide a uniform taper. The weld may be partly or entirely in the tapered section or adjacent to it as indicated in [Figure HW-701.1](#). The transition requirement also applies when there is a reduction in thickness within a cylindrical shell course and to tapers within formed heads. In longitudinal shell joints, the middle lines of the adjoining thicknesses shall be in alignment within the fabricating tolerances specified in [HW-812](#).

(b) Where fusion welded steel plate boilers are made up of two or more courses, the welded longitudinal joints of adjacent courses shall be not less than 6 in. (150 mm) apart.

HW-701.2 Lap Joints.

(a) Boilers designed for not more than 30 psi (200 kPa) and having inside diameters not exceeding 24 in. (600 mm) may have longitudinal or circumferential joints uniting plates of a shell made with lap joints, provided the joint is not in direct contact with the products of combustion.

(b) For boilers over 30 psi (200 kPa) or 24 in. (600 mm) I.D., lap joints may be used only where stayed plates are joined, where a cylindrical shell and a stayed wrapper are joined, or as permitted in [HW-711](#).

(c) Except as permitted in [HW-701.4](#) and [HW-711](#), lap joints shall be full fillet welded inside and outside and the throats of the fillet welds shall be not less than 0.7 times the thickness of the thinner plate. The surface overlap shall be not less than 4 times the thickness of the thinner plate.

HW-701.3 Corner or Tee Joints.

(a) Boilers designed for not more than 30 psi (200 kPa) may have the corner or tee joints made with single full fillet welds. The throat of the fillet weld shall be not less than 0.7 times the thickness of the thinner plate joined [see [Figure HW-701.3](#), sketches (a), (b), and (c)].

(b) Hot water boilers designed to these rules for pressures in excess of 30 psi (200 kPa) shall have corner or tee joints made only with full penetration welds [see [Figure HW-701.3](#), sketches (d) and (e)] or double full fillet welds [see [Figure HW-701.3](#), sketch (f)].

HW-701.4 Single Fillet Joints for Lap Attachment of U-Bend Tubes. Tubes bent to a nominal 180 deg to form a U-bend may be attached to headers by fillet welds provided

(a) the header is not larger than NPS 3 (DN 80)

(b) the maximum thickness of the parts being joined is $\frac{3}{8}$ in. (10 mm)

(c) the tubes are inserted, coaxially with a forced fit for a minimum distance of 1.5 times the minimum thickness of the parts being joined, into the end of the header and are attached by fillet welds

Figure HW-701.1
Butt Welding of Plates of Unequal Thickness

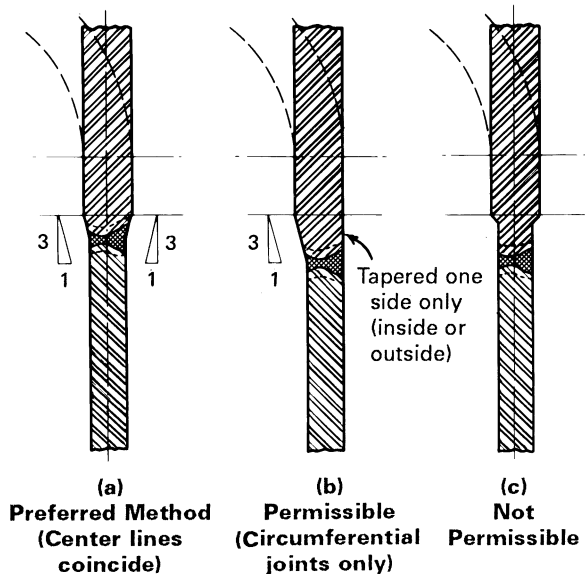

(d) the fillet welds are deposited from the outside only with one leg not smaller than the thickness of the header and the other leg not smaller than 1.3 times the thickness of the thinnest part being joined, and

(e) the fillet weld shall not be in contact with primary furnace gasses

HW-702 Joint Efficiencies

The following joint efficiencies E are to be used in e., [HG-301](#) and [HG-305](#) for joints completed by an arc or gas welding process:

(a) $E = 85\%$ for full penetration butt joints as attained by double welding or by other means that will obtain the same quality of deposited weld metal on the inside and outside weld surfaces, to provide complete joint penetration and assurance that the weld grooves are completely filled ([HW-701.1](#)). Welds that use metal backing strips that remain in place are excluded.

(b) $E = 80\%$ for full penetration single-welded butt joints with backing strips other than those included in (a) above.

(c) $E = 60\%$ for single-welded butt joints without use of backing strips.

(d) $E = 65\%$ for double full fillet lap joints meeting the requirements of [HW-701.2\(b\)](#).

(e) $E = 49\%$ for double full fillet lap joints meeting the requirements of [HW-701.2\(a\)](#).

HW-702.1 Joint Efficiencies for External Pressure Design. Joint efficiency E factors are not required to be used when the boiler part is designed for external pressure only.

HW-703 Minimum Thickness of Welded Parts

The minimum thicknesses specified in [HF-301](#) and Section II, Part D, Table 6A or Table 6B apply if greater than the thicknesses calculated utilizing the above listed joint efficiency factors with equations of this Section.

HW-710 Welded Stays

HW-710.1 Insertion of Stays. Except as provided in [HW-710.4](#), the stays are to be inserted into holes through the plate and extended at least through the full thickness of the plate.

HW-710.2 Projection of Stays Exposed to Primary Furnace Gases. The ends of stays inserted through plates shall not project more than $\frac{3}{8}$ in. (10 mm) beyond surfaces of the plate exposed to primary furnace gases.

HW-710.3 Welding of Stays. Stays for pressures 30 psi (200 kPa) or less shall be attached by fillet welds, partial penetration groove welds, or full penetration welds. Stays for greater than 30 psi (200 kPa) shall be attached by full penetration welds (use of weld backing rings is optional).

(a) To provide for the above specified welding, the plate may be countersunk by machining or pressing, or the stay may protrude through the plate, or a combination of those methods may be used.

(b) The size of the weld in shear, measured parallel to that portion of the stay in or extended through the plate, shall be not less than $\frac{5}{16}$ times the required diameter of the stay and in no case less than $\frac{1}{4}$ in. (6 mm). For a stay with other than circular cross section, the minimum size of the weld shall be that calculated for a circular stay of the same cross-sectional area.

(c) The end of the stay shall not be covered by weld metal and shall not be below the surface of the plate and the fit-up and welding shall be such that excessive weld deposits do not project beyond the surface of the plate at the root of the weld.

HW-710.4 Welding of Diagonal Stays. Diagonal stays shall be attached to the inner surface of the shell, but not to a head or tubesheet, by fillet welds only provided the following [see [Figures HW-710.4\(a\)](#) and [HW-710.4\(b\)](#)]:

Figure HW-701.3
Some Forms of Attachments of Pressure Parts to Flat Plates to Form a Corner Joint (Tee Joint)

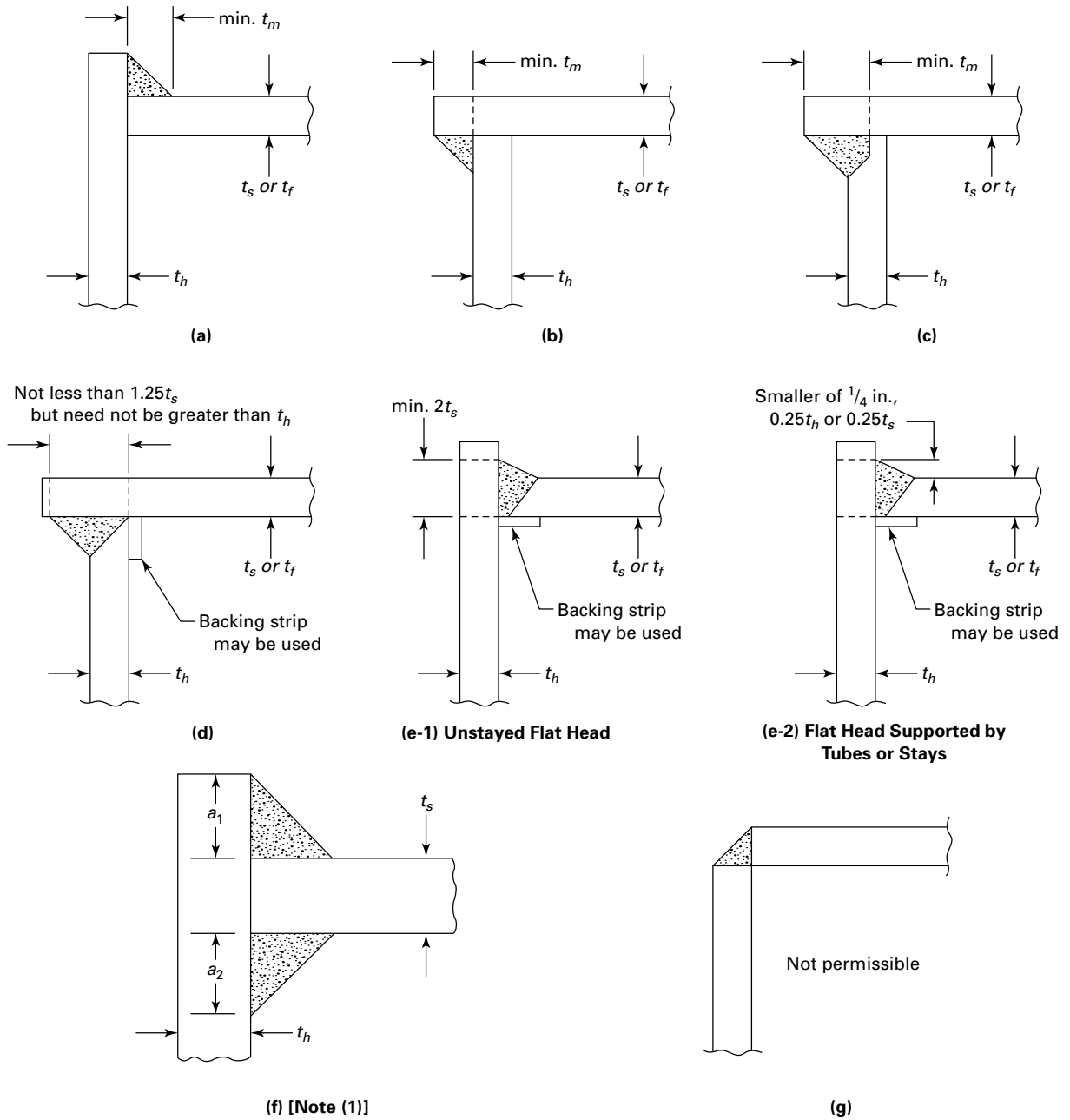

Legend:

- t_f = nominal furnace thickness
- t_h = nominal head thickness
- t_m = lesser of t_s , t_h , or t_f as applicable
- t_s = nominal shell thickness

GENERAL NOTES:

- (a) Illustrations (a), (b), and (c) are permissible for boilers for pressures up to 30 psi (200 kPa).
- (b) Illustrations (d), (e-1), (e-2) or (f) are required for boilers designed for pressures over 30 psi (200 kPa).
- (c) Illustration (g) is not permissible.

NOTE: (1) $a_1 + a_2 = 2t_m$, where a_1 is not less than $0.5a_2$ nor greater than $2a_2$.

Figure HW-710.4(a)
Some Acceptable Types of Diagonal Stays for
Installation by Welding

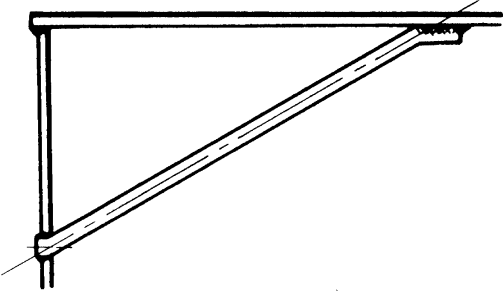

GENERAL NOTE: A round bar or a round bar with a forged palm.

Figure HW-710.4(b)
Unacceptable Types of Diagonal Stays for Installation by Welding

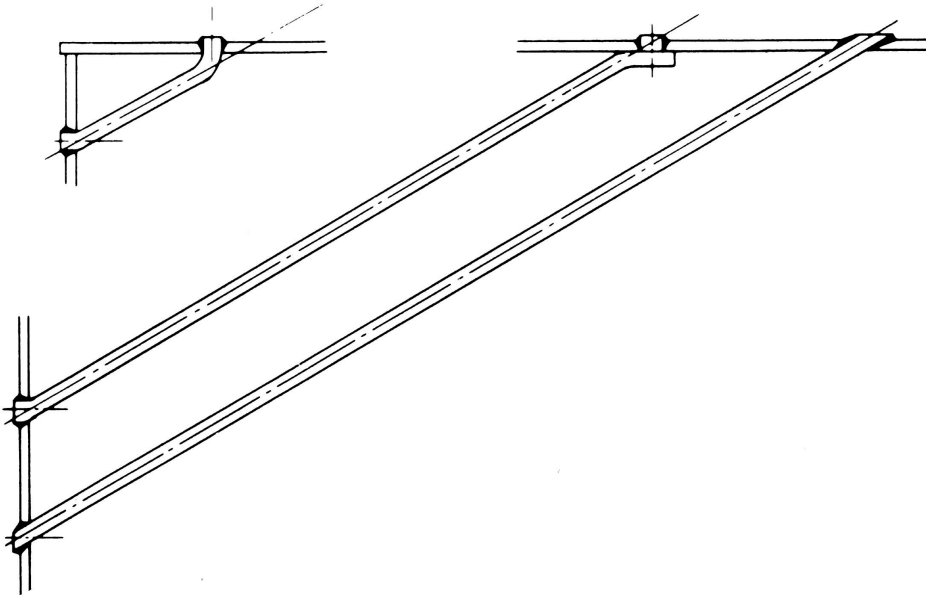

(a) Fillet welds shall be not less than $\frac{3}{8}$ in. (10 mm) size and shall continue the full length of each side of the portion of the stay in contact with the shell. The product of the aggregate length of these fillet welds times their throat shall be not less than 1.25 times the required cross-sectional area of the stay. A fillet weld across the end of the stay is optional but shall not be credited in calculating the required area of fillet welds.

(b) The longitudinal center line of the stay (projected if necessary) shall intersect the surface of the plate to which the stay is attached within the outer boundaries of the attaching welds (also projected if necessary).

(c) Diagonal stays shall, for boilers designed for not more than 30 psi (200 kPa) pressure, comply with the requirements of [HW-710.1](#), [HW-710.2](#), and [HW-710.3](#).

HW-711 Heads or Tubesheets Attached by Welding

HW-711.1 Flanged Heads or Tubesheets. Boilers may be constructed by attaching an outwardly or inwardly flanged head or tubesheet to the shell by fillet welding provided

(a) the head or tubesheet is supported by tubes, or braces, or both

(b) the joint attaching an outwardly flanged head or tubesheet is wholly within the shell and forms no part thereof

(c) inwardly flanged heads or tubesheets are full fillet welded inside and outside

(d) the throats of the full fillet welds are not less than 0.7 times the thickness of the head or tubesheet

(e) on inwardly flanged heads or tubesheets, the minimum length of the straight flange shall conform with the requirements of [HW-701.2](#)

(f) the shell at the weld is not in contact with primary furnace gases

(g) these constructions shall not be used on the rear head of a horizontal-return tubular boiler, and inwardly flanged heads or tubesheets shall not be used on a boiler with an extended shell

HW-711.2 Unflanged Heads or Tubesheets. Boilers may be constructed by attaching unflanged heads or tubesheets to the shell by welding, provided

(a) the head or tubesheet is supported by tubes or braces, or both, as required by [HG-340](#), or its thickness is calculated using the appropriate formula from [HG-307](#)

(b) the welding for boilers designed for not more than 30 psi (200 kPa) meets the minimum requirements for [HW-701.3\(a\)](#)

(c) the weld for boilers designed for pressure in excess of 30 psi (200 kPa) is a full penetration weld applied from either or both sides as shown in [Figure HW-701.3](#), sketch (d), (e-1), or (e-2) or a double full fillet weld as shown in [Figure HW-701.3](#), sketch (f)

(d) the shell or wrapper sheet, where exposed to primary furnace gases and not water cooled, shall not extend beyond the outside face of the head or tubesheet for a distance greater than the thickness of the head or tubesheet

(e) this construction shall not be used on the rear head of a horizontal-return tubular boiler

HW-712 Furnace Attachments

HW-712.1 For Pressures Not More Than 30 psi (200 kPa). A furnace or crown sheet in a boiler designed to these rules for pressures not more than 30 psi (200 kPa) may be attached to a head or tubesheet with a fillet weld as shown in [Figure HW-701.3](#), sketch (a) or (b), provided

(a) the furnace, head, or tubesheet projections shall not extend beyond the outside face of the abutting plate or furnace for a distance greater than t_m , unless protected by refractory material; the furnace shall be trimmed to remove any excess material before welding

(b) the throat of the full fillet weld is not less than 0.7 times the smaller of the following:

(1) the thickness of the furnace

(2) the thickness of the head or tubesheet

(c) the joint attaching a cylindrical furnace to a head or tubesheet is wholly outside the cylindrical portion of the furnace

HW-712.2 For Pressures in Excess of 30 psi (200 kPa). A furnace or crown sheet in a hot water boiler designed to these rules for pressures in excess of 30 psi (200 kPa) shall be attached to a head or tubesheet, as shown in [Figure HW-701.3](#), sketch (d), (e-1), or (e-2), by a full penetration weld. When exposed to primary gases, the furnace, head, or tubesheet before projections shall not extend beyond the face of the abutting plate or furnace by more than $\frac{3}{8}$ in. (10 mm), unless protected by refractory material.

HW-713 Tubes Attached by Welding

(a) The edge of the plate at the tubesheet hole may be beveled or recessed. The depth of any bevel or recess shall not be less than the tube thickness. Where the plate is beveled or recessed, the projection of the tubes beyond the tube sheet shall not exceed a distance equal to the tube thickness, but shall extend at least through the tubesheet.

(b) The maximum and minimum distance the firetube shall extend through the tubesheet shall be in accordance with [Table HW-713](#).

(c) The minimum fillet weld throat plus groove weld depth (if present) shall be no smaller than the tube thickness. For tubes that are not exempt from calculations as stays by [HG-346.3](#), the area of the weld in shear measured parallel to the axis of the tube at the outside diameter of

**Table HW-713
Firetube Extension Through Tubesheets for Welded Construction**

	Tubes Exposed to Primary Furnace Gases [Note (1)]	Tubes Not Exposed to Primary Furnace Gases [Note (1)]
Tubesheet beveled or recessed	min. = the tube shall extend at least through the tubesheet max. = t_{tube}	min. = the tube shall extend at least through the tubesheet max. = greater of t_{tube} or $\frac{3}{8}$ in. (10 mm)
Tubesheet not beveled or recessed	min. = t_{tube} [Note (2)] max. = greater of t_{tube} or $\frac{1}{4}$ in. (6 mm)	min. = t_{tube} [Note (2)] max. = greater of t_{tube} or $\frac{3}{8}$ in. (10 mm)

NOTES:

(1) See [HG-360.2](#).

(2) For firetubes attached using laser beam welding, the minimum tube extension may be smaller than the tube thickness provided the tube extends at least through the tubesheet. In addition, the welding procedure and the performance qualification shall be performed in accordance with Section IX, QW-193, and the required depth of penetration of the tube-to-tubesheet weld shall be at least 1.25 times the tube thickness.

the tube shall additionally not be less than 1.25 times the cross-sectional area of the tube required by [HG-342.1](#).

(d) The above projections do not apply to watertubes; the maximum projection for watertubes is $\frac{1}{2}$ in. (13 mm). For attachment of watertubes by welding, see [HW-731](#).

HW-715 Head-to-Shell Attachments

Ellipsoidal, torispherical, hemispherical, and other types of formed heads, concave or convex to the pressure shall have the following requirements as to skirt length.

(a) See below.

(1) An ellipsoidal or torispherical head that is attached to a shell by a butt joint need not be provided with a skirt when the nominal head thickness does not exceed $1\frac{1}{4}$ times the nominal shell thickness. When the nominal head thickness exceeds $1\frac{1}{4}$ times the nominal shell thickness, a skirt shall be provided having a length not less than three times the nominal head thickness or $1\frac{1}{2}$ in. (38 mm), whichever is smaller. When a skirt is used it shall meet the requirements for shell thickness in [HG-301](#).

(2) Flanged heads concave to pressure may be attached to shells using a butt weld with one plate offset as shown in [Figure HW-715.1](#) provided the welded joint is not in contact with primary furnace gases. The offset shall be smooth and symmetrical and shall not be machined or otherwise reduced in thickness. There shall be a uniform force fit with the mating section at the root of the weld.

(b) Ellipsoidal or torispherical heads, concave or convex to the pressure, shall have a skirt length not less than that shown in [Figure HW-715.1](#) provided the welded joint is not in contact with primary furnace gases. Heads that are fitted inside or over a shell shall have a driving fit before welding.

(c) Formed heads of full hemispherical shape, concave to pressure, need not have an integral skirt, but where a skirt is provided for butt-welded attachment, the thickness of the skirt shall be at least that required for a seamless cylindrical shell of the same diameter.

(d) Flanged ellipsoidal or torispherical heads convex to pressure may be attached to the shell with a full fillet weld with throat no less than 0.7 times the head thickness. The shell at the weld shall not be in contact with primary furnace gases.

HW-720 Openings in Welds

Any type of opening that meets the requirements for reinforcement given in [HG-321](#) may be located in a butt-welded joint.

HW-730 Welded Connections

HW-730.1 Strength of Attachment Welds.

(a) Nozzles, other connections, and their reinforcement may be attached to a boiler by arc or gas welding. Sufficient welding shall be provided on either side of the line through the center of the opening parallel to the longitudinal axis of the shell to develop the strength of the shell as prescribed in [HG-327](#) through shear or tension in the weld, whichever is applicable. The strength of groove welds shall be based on the area subjected to shear or to tension. The strength of fillet welds shall be based on the area subjected to shear, computed on the minimum leg dimension. The inside periphery of fillet weld shall be used in computing its length.

(b) Weld strength calculations for pressure loadings are not required for the following:

(1) nozzle connections made per [Figure HW-731](#), sketches (a), (b), (c), (g), (h), (o-1), (s-1), (u-1), (v-1), and (w-1)

**Figure HW-715.1
Heads Attached to Shells**

(23)

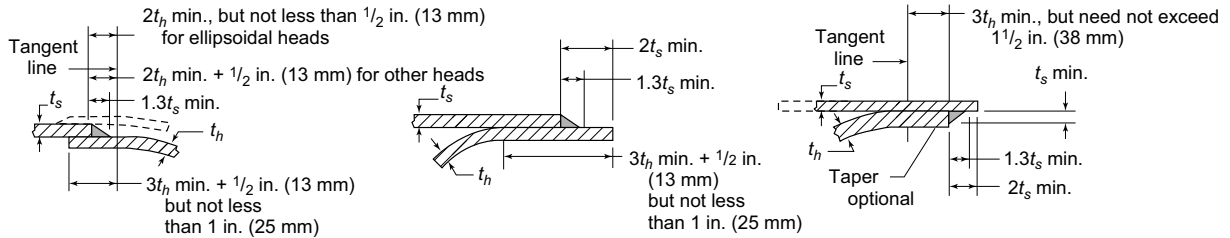

(a) Single Fillet Weld

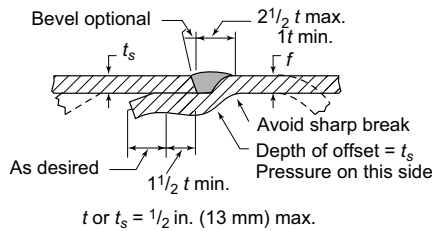

(b) Butt Weld With One Plate Edge Offset

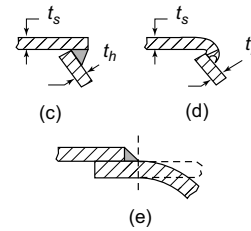

Details (c), (d), and (e) are not permissible

(2) nozzle connections for openings that are exempt from reinforcement requirements by [HG-320.3\(c\)](#) or [HG-320.3\(d\)](#), and

(3) openings designed in accordance with the rules for ligaments in para. [HG-350](#)

HW-730.2 Stress Values for Weld Metal. The allowable stress values for groove and fillet welds and for shear in nozzle necks in percentages of stress values for the vessel material are as follows:

Factor	Percentage of Stress Values, %
Nozzle-wall shear	70
Groove-weld tension	74
Groove-weld shear	60
Fillet-weld shear	49

GENERAL NOTE: These values are obtained by combining the following factors: 87 1/2% for combined end and side loading, 80% for shear strength, and the applicable joint efficiency factors.

HW-730.3 Telltale Holes in Reinforcement Plates and Saddles. Separate reinforcement plates and saddles used to reinforce the material around openings and that are attached to the outside of a boiler shall be provided with at least one telltale hole [maximum size: 1/4 in. (6 mm) pipe tap] that may be tapped for a preliminary compressed-air and soapsuds test for tightness of welds that seal off the inside of the boiler. These telltale holes may be left open when the boiler is in service. If the

holes are plugged, the plugging material used shall not be capable of sustaining pressure between the plate and the boiler wall.

HW-730.4 Stud Welds. Arc stud welding and resistance stud welding, as defined in [E-102](#), where the boiler pressure exerts a tensile load on the studs, may be used only for the attachments of bolted unstayed flat heads, cover plates and blind flanges, handholes and manholes, with the further limitations as follows:

(a) Studs attached by stud welding shall not be in direct contact with products of combustion or flue gases.

(b) Where the pressure exerts a tensile load on the studs, a full-face gasket must be used on flat heads, cover plates and blind flanges attached by stud welding.

(c) The minimum size stud used shall be not less than 1/4 in. (6 mm) nominal diameter, and the maximum size shall not exceed 7/8 in. (22 mm) nominal diameter.

(d) The type of stud shall be limited to round externally threaded studs.

(e) Base metal shall be of ferrous material specification as permitted by this Section, and the base metal must be thick enough to prevent burn through. See [HW-500\(b\)](#) for stud material.

(f) The maximum spacing of studs shall not exceed 12 times the nominal diameter of the stud.

(g) The maximum allowable stress for the stud shall be 7800 psi (54 MPa) based on the smallest cross-sectional area (i.e., the root of the thread).

HW-731 Minimum Requirements for Attachment Welds

HW-731.1 General. The location and minimum size of attachment welds for nozzles and other connections shall conform to the requirements in this paragraph.

(a) *Notation.* The symbols used in this paragraph and in [Figure HW-731](#) are defined as follows:

- t = nominal thickness of boiler shell or head
- t_1, t_2 = not less than the smaller of $\frac{1}{4}$ in. (6 mm) or $0.7t_{\min}$ and $t_1 + t_2$ not less than $1\frac{1}{4}t_{\min}$
- t_c = not less than the smaller of $\frac{1}{4}$ in. (6 mm) or $0.7 t_{\min}$. (inside corner welds may be further limited by a lesser length of projection of nozzle wall beyond the inside face of the boiler wall)
- t_{\min} = the smaller of $\frac{3}{8}$ in. (19 mm) or the thickness of the thinner of the parts joined by a fillet, single-bevel, or single-J weld
- t_n = nominal thickness of nozzle wall
- t_w = dimension of partial penetration attachment welds (fillet, single-bevel, or single-J), measured as shown in [Figure HW-731](#)

HW-731.2 Necks Abutting the Boiler Shell.

(a) Nozzles abutting the boiler shell shall be attached by a full penetration groove weld. Backing strips shall be used with welds deposited from only one side when the shell thickness is over $\frac{3}{8}$ in. (10 mm) or when complete joint penetration cannot be verified by visual inspection [for example, see [Figure HW-731](#), sketch (y)].

(b) Nozzles or tubes recessed into thick boiler shells or headers may be welded from only one side by cutting a welding groove in the boiler shell to a depth of not less than t_n on the longitudinal axis of the opening. It is recommended that a recess at least $\frac{1}{16}$ in. (1.5 mm) deep be provided at the bottom of the groove in which to center the nozzle. The dimension t_w of the attachment weld shall be not less than t_n or less than $\frac{1}{4}$ in. (6 mm) [for example, see [Figure HW-731](#), sketch (y)].

HW-731.3 Inserted Nozzles Without Added Reinforcement Elements.

(a) Nozzles inserted into or through a hole cut in the boiler shell and without additional reinforcement elements shall be attached by a full penetration groove weld or by two partial penetration welds, one on each face of the boiler shell. Permissible types of welds are shown in [Figure HW-731](#), sketches (c) through (h).

(b) Backing strips shall be used with full penetration welds deposited from one side only when the shell thickness is over $\frac{3}{8}$ in. (10 mm) or when complete joint penetration cannot be verified by visual inspection. The two

partial penetration welds may be any desired combination of fillet, single-bevel, and single-J welds. The dimension t_w of each weld shall be not less than the smaller of $\frac{1}{4}$ in. (6 mm) or $0.7t_{\min}$ and their sum shall be not less than $1\frac{1}{4}t_{\min}$ (see [Figure HW-731](#)).

HW-731.4 Inserted Nozzles With Added Reinforcement.

Inserted type nozzles having added reinforcement in the form of one or more separate reinforcement plates shall be attached by welds at the nozzle neck periphery and at the outer edge of each reinforcement plate. The weld at the outer edge of each reinforcement plate shall be a fillet weld with a minimum throat dimension of $\frac{1}{2}t_{\min}$. The welds attaching the nozzle to the boiler shell and to the reinforcement shall consist of one of the following combinations:

(a) a single-bevel or single-J weld in the shell plate, and a single-bevel or single-J weld in each reinforcement plate. The dimension t_w of each weld shall be not less than $0.7t_{\min}$ [see [Figure HW-731](#), sketch (n)].

(b) a full penetration groove weld in the shell plate, and a fillet, single-bevel, or single-J weld with a weld dimension t_w not less than $0.7t_{\min}$ in each reinforcement plate [see [Figure HW-731](#), sketch (m)].

(c) a full penetration groove weld in each reinforcement plate, and a fillet, single-bevel, or single-J weld with a weld dimension t_w not less than $0.7t_{\min}$ in the shell plate [see [Figure HW-731](#), sketch (l)].

HW-731.5 Nozzles With Integral Reinforcement.

Nozzles and other connections having integral reinforcement in the form of extended necks or saddle type pads shall be attached by a full penetration weld or by means of a fillet weld along the outer edge and a fillet, single-bevel, or single-J weld along the inner edge. The throat dimension of the outer weld shall be not less than $\frac{1}{2}t_{\min}$. The dimension t_w of the inner weld shall be not less than $0.7t_{\min}$ [see [Figure HW-731](#), sketch (k)].

HW-731.6 Fittings. The attachment of fittings shall meet the following requirements.

(a) Except as provided for in [HW-731.7](#), fittings shall be attached by a full penetration groove weld or by two fillet or partial penetration welds, one on each face of the boiler wall. The minimum weld dimensions shall be as shown in [Figure HW-731](#), sketches (u) through (x).

(b) Flange-type fittings not exceeding NPS 3 (DN 80) as shown in [Figure HW-731](#), sketch (w-4), may be attached without additional reinforcement other than that in the fitting and its attachments, provided all of the following conditions are met:

(1) The boiler wall thickness shall not exceed $\frac{3}{8}$ in. (10 mm).

(2) The minimum fillet leg shall be $\frac{3}{32}$ in. (2.5 mm).

(3) The opening in the boiler wall shall not exceed the outside diameter of the nominal pipe plus $\frac{3}{4}$ in. (19 mm).

Figure HW-731
Some Acceptable Types of Welds for Fittings, Nozzles, and Other Connections to Shells, Drums, and Headers

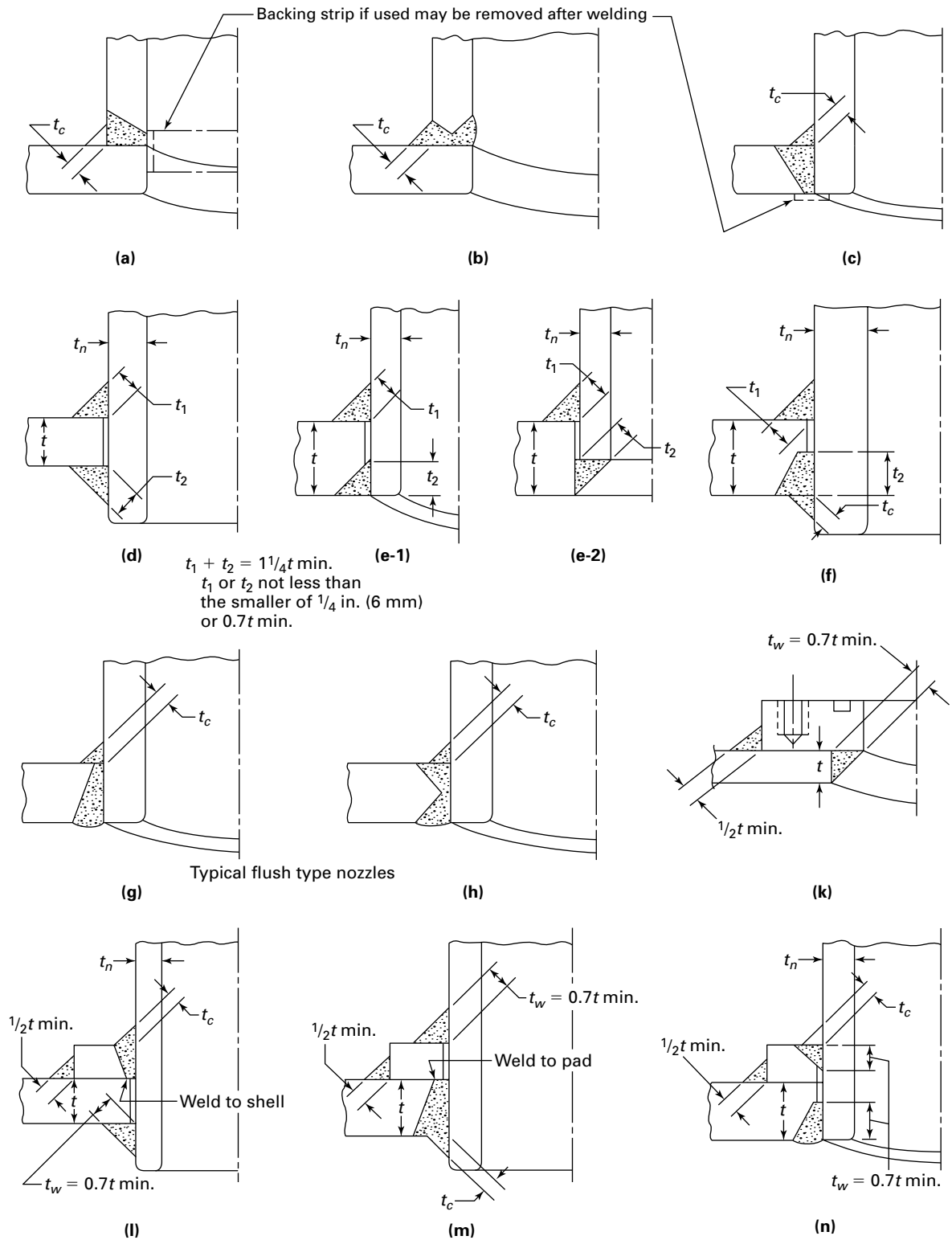
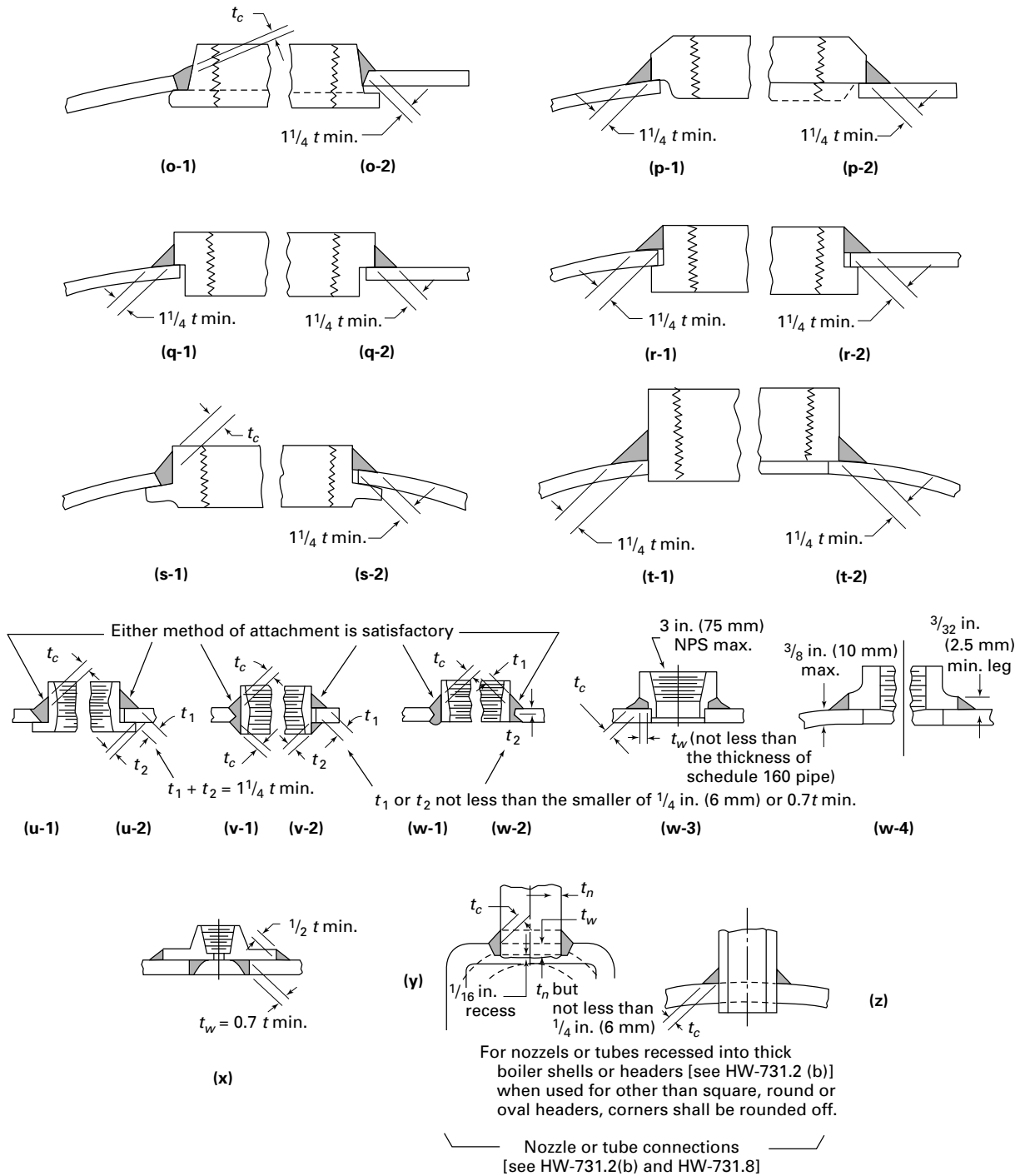
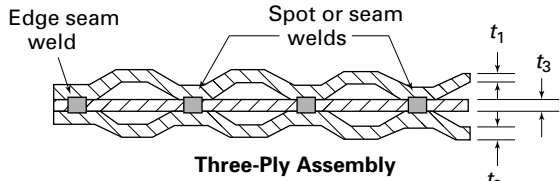

Figure HW-731
Some Acceptable Types of Welds for Fittings, Nozzles, and Other Connections to Shells, Drums, and Headers (Cont'd)



**Figure HW-740
Three-Ply Joint Assemblies**



(a) Two Outer Embossed or Dimpled Plates Welded to Inner Flat Plate

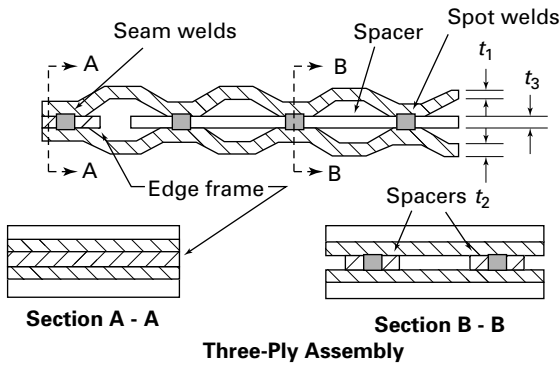

(b) Two Outer Embossed Plates Welded to Inner Edge Frame and Spacers

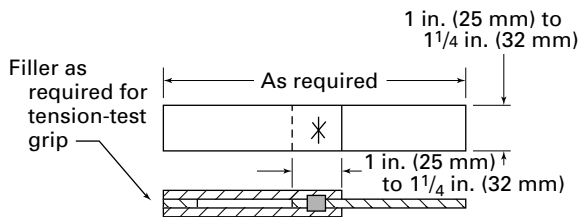

(c) Spot-Welded Tension Specimen for Three-Ply Joint

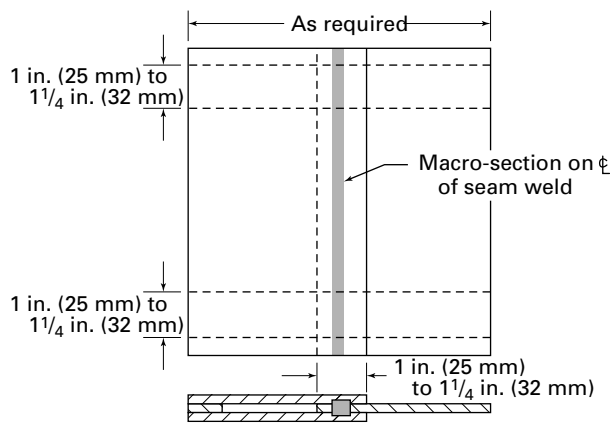

(d) Seam-Welded Specimen for Tension and Macro-section for Three-Ply Joint

HW-731.7 Fittings and Nozzles Not Exceeding NPS 3 (DN 75).

(a) Fittings, nozzles, or equivalent bolting pads may be attached to vessels having a wall thickness not greater than $\frac{3}{8}$ in. (10 mm) by a fillet weld deposited from the outside only, having the minimum dimensions shown in Figure HW-731, sketches (o) through (t).

(b) Fittings shown in Figure HW-731, sketches (u-2), (v-2), (w-2), and (x), may be attached by welds that are exempt from size requirements other than those specified in HW-730.1.

(c) Fittings may be attached by a groove and fillet weld from the outside only as shown in Figure HW-731, sketch (w-3). The groove weld t_w shall not be less than the thickness of Schedule 160 pipe (ASME B36.10). The external fillet weld throat shall be not less than t_c .

(d) Fittings and nozzles not exceeding NPS $1\frac{1}{2}$ (DN 40) as shown in Figure HW-731, sketches (t-1) and (t-2) may be attached to vessels by a fillet weld deposited from the outside only provided the following conditions are met:

(1) The boiler wall thickness shall not exceed $\frac{3}{8}$ in. (10 mm).

(2) The fillet weld shall be a minimum of $0.7t$ instead of $1\frac{1}{4}t_{min}$ shown in Figure HW-731, sketches (t-1) and (t-2), but in no case less than $\frac{3}{32}$ in. (2.5 mm) leg.

HW-731.8 Watertube Attachments. Watertubes not exceeding $3\frac{1}{2}$ in. (89 mm) O.D. may be attached to tubesheets with fillet welds deposited from the outside only, having a minimum weld dimension as shown in Figure HW-731, sketch (z) [see HG-360.3(d)].

HW-740 Resistance Welding in Carbon Steel for Other Than Butt-Welded Joints

Resistance spot and seam welding may be used in the construction of embossed or dimpled assemblies under the following limitations and additional requirements:

(a) Materials used in the resistance welded parts are SA-285 and SA-414 with the further limitation that the carbon content is 0.15 maximum on heat analysis.

(b) Embossed or dimpled assemblies consist of either two embossed plates welded together, or two dimpled plates welded together, or an embossed or dimpled plate welded to a flat plate as in Figure HW-745 sketch (a). A third, intermediate plate, frame, or series of spacers, as illustrated in Figure HW-740, sketch (a) or (c), may be used to form a three-ply assembly.

(c) The allowable working pressure for resistance welded embossed or dimpled assemblies shall be the lowest pressure established by the following:

(1) a proof test in accordance with the requirements of HG-500.

(2) the computed value of the plain plate, if used in resistance spot-welded construction. The plain plate, if used, shall meet the requirements for braced and stayed surfaces in [HG-340](#).

(3) the computed value of the plain plate if used in resistance seam-welded construction. The plain plate, if used, shall meet the requirements of [HG-307.3\(a\)](#), eqs. (3) and (4), with $z = 2.5$ max., $c = 0.2$.

(d) In lieu of the Procedure and Performance Qualification requirements of Section IX, the following requirements shall be met for resistance spot-welded and resistance seam-welded pressure vessels.

(1) *Proof Test.* A pressure proof test to destruction shall be conducted on a finished vessel or representative panel. The test shall be conducted as specified in [HG-502.3](#). If a representative panel is used, it shall be rectangular in shape and at least 5 pitches in each direction, but not less than 24 in. (600 mm) in either direction.

(2) *Workmanship Samples*

(-a) Three single spot-welded specimens, and/or one seam-welded specimen, as shown in [Figure HW-745](#) for two-ply joints, and in [Figure HW-740](#) for three-ply joints, shall be made immediately before and after the welding of the proof test vessel. These test specimens shall be representative of the manufacturing practice employed in the fabrication of the proof test vessel. When a difference in the amount of magnetic material in the throat of the machine or the part geometry precludes the welding of satisfactory test specimens at the same machine settings as those used for the proof test vessel, sufficient material shall be placed in the throat of the welding machine to compensate for the difference in size of the proof test panel and the small test specimens.

(-b) The spot-welded specimens shall be subjected to tensile loading for ultimate strength and visually inspected for nugget size, electrode indentation, and evidence of defects. The seam-welded specimens shall be similarly tested for ultimate strength and prepared for macrographic examination to reveal nugget size, spacing, penetration, soundness, and surface conditions.

(-c) In addition, a typical spot weld sample and seam-welded sample shall be cut from the proof test vessel after failure. A portion of each sample shall be sectioned for macroetch examination.

(-d) All pertinent information obtained from the foregoing tests shall be recorded. These samples and data constitute workmanship samples that shall be available for comparison with quality control specimens that may be made during production.

(-e) With every change in production run of material or gage, the machine setting control will be verified by test samples.

(3) *Machine Settings and Controls.* The resistance welding machine settings and process control parameters used in the making of the proof test vessel and the work-

manship samples shall be recorded. Except for minor variations and adjustments as may be permitted at the discretion of the Authorized Inspector, the applicable settings shall be used in the fabrication of all vessels in a given production run.

(4) *Pressure Tests and Inspection.* All production vessels shall be pressure tested to a pressure not less than 1.5 times the allowable working pressure. These tests and inspection during fabrication shall be in accordance with [HG-510](#).

(5) *Records.* Records shall be kept of all data obtained from tests of the proof test vessel, the workmanship samples, the welding machine settings, the welding procedure, and process control parameters. Records shall be kept of all preheat, postheat, and heat-treatment procedures and of inspection procedures.

(6) If spot- and seam-welding machines other than those used for the initial proof test vessel and workmanship samples are to be used in production, each additional machine and welding procedure shall be qualified in full accordance with (d). The performance of the additional proof test vessels shall substantiate the allowable working pressure previously established for the specific boiler design.

(7) Lap joints only, between two thicknesses of metal sheet, may be resistance spot or seam welded. The use of projection welding (including resistance stud welding) is excluded.

(8) The range of thickness of sheet materials that may be resistance spot or seam welded under this case shall be as follows:

(-a) *Two-Ply Joints* [See [Figure HW-745](#), Sketch (a)]

(-1) The minimum thickness t_1 or t_2 shall be 0.045 in. (1.14 mm).

(-2) The maximum thickness t_1 or t_2 shall be $\frac{1}{4}$ in. (6 mm) nominal.

(-b) *Three-Ply Joints* [See [Figure HW-740](#), Sketches (a) and (b)]

(-1) The two outer layers t_1 and t_2 shall be equal in thickness.

(-2) The inner layer t_3 shall be at least as thick as t_1 or t_2 .

(-3) The minimum thickness of t_1 , t_2 , and t_3 shall be 0.045 in. (1.14 mm).

(-4) The maximum thickness of t_1 and t_2 shall be 0.126 in. (3.20 mm).

(-5) The maximum thickness of t_3 shall be 0.188 in. (4.8 mm).

(-6) The total thickness of the three layers $t_1 + t_2 + t_3$ shall be 0.135 in. (3.43 mm) min., 0.378 in. (10 mm) max.

HW-745 Resistance Welding of Hydraulically Formed Panels

Resistance spot and seam welding may be used in the construction of embossed or dimpled assemblies under the following limitations and additional requirements.

(a) Materials used in the resistance welded parts of such vessels are carbon steel SA-285, SA-620, and SA-414, or any proven combination, with the further limitation that the carbon content is 0.15% maximum.

(b) Construction consists of employing resistance spot welding or resistance seam welding to join two sheets together [see Figure HW-740, sketch (a)]. Subsequent to the joining and sealing operation, the assembly is subjected to a hydraulic or pneumatic pressure to achieve a dimpled formation.

Construction may consist of two sheets of equal thickness that results in the formation of a dimpled surface on both sides of an assembly or two sheets of different thicknesses that results in the formation of a dimpled surface on only one side of a pressure assembly. Any number of such assemblies may be joined together, by fusion welding, to make a boiler or boiler parts.

(c) The allowable working pressure for the construction shall be the lowest pressure established by the following:

(1) a proof test in accordance with the bursting test procedures in HG-502 and HG-503 need not be followed, provided that when performing the proof test, the application of pressure is continuous until burst or until the proof test is stopped. In using the formulas for calculating the maximum allowable working pressure, a value of 0.80 shall be used for E , the weld joint efficiency factor. All provisions of HG-501 and HG-504 shall apply.

(2) the computed value of the plain plate, if used in resistance spot-welded construction. The plain plate, if used, shall meet the requirements for braced and stayed surfaces in HG-340.

(3) the computed value of the plain plate, if used in resistance seam-welded construction. The plain plate, if used, shall meet the requirements of HG-307.3(a), eqs. (3) and (4), with $z = 2.5$ max., $c = 0.2$, and $E = 1.0$.

(d) The following design limitations apply:

(1) A change in any of the following variables will require requalification of the design proof test of (c):

(-a) an increase in the spot or row pitch exceeding $\frac{1}{16}$ in. (1.5 mm)

(-b) a change in the specification, type, or grade of material or material thickness for either sheet or both sheets

(-c) a change in the electrode size or material

(2) A duplicate test panel of that used to establish the maximum allowable working pressure shall be inflated to a pressure at least 5% greater than the maximum forming pressure to be used in production. The rate of pressurization shall be the same as that used in the burst test. The panel shall be sectioned to show at least six spot welds [see

Figure HW-745, sketches (d-1) and (d-2)]. The weld cross sections shall be subjected to macroetch examinations and shall show no cracks. The maximum pillow heights measured, as shown in Figure HW-745, sketch (e), of panels made in production shall not exceed 95% of the maximum pillow height of this duplicate test panel. The maximum forming pressure shall not exceed 80% of the burst pressure.

(e) In lieu of the Procedure Qualification requirements of Section IX, the following requirements shall be met for resistance spot-welded and resistance seam-welded panels.

(1) *Proof Test.* A pressure proof test to destruction as set forth in (c)(1) above shall be conducted on a finished boiler or representative panel. This test may be a separate test or part of the test in (c)(1) above. If a representative panel is used, it shall be rectangular in shape and at least 5 pitches in each direction, but not less than 24 in. (600 mm) in either direction.

(-a) A typical spot-welded sample and seam-welded sample shall be cut from the proof test panel after failure. A portion of each sample shall be sectioned for macroetch examination.

(2) *Workmanship Samples*

(-a) Three single spot-welded specimens, and/or one seam-welded specimen as shown in Figure HW-745, sketches (b) and (c), shall be made immediately before and after the welding of the proof test panel. These test specimens shall be representative of the manufacturing practice employed in the fabrication of the proof test panel. When a difference in the amount of magnetic material in the throat of the welding machine or the part geometry precludes the welding of satisfactory test specimens at the same machine settings as those used for the proof test panel, sufficient material shall be placed in the throat of the welding machine to compensate for the difference in size of the proof test panel and the small test specimens.

(-b) The spot-welded specimens shall be subjected to tensile loading for ultimate strength and visually inspected for nugget size, electrode indentation, and evidence of defects. The seam weld specimens shall be similarly tested for ultimate strength and prepared for macrographic examination to reveal nugget size, spacing, penetration, soundness, and surface condition.

(-c) All pertinent information obtained from the foregoing tests shall be recorded. These samples and data constitute workmanship samples that shall be available for comparison with quality control specimens that may be made during production.

(-d) With every change of material gage, the machine setting control shall be verified by test samples.

(-e) At the beginning of each production run, which is a group of panels or assemblies all produced during a 24 hr period using the same welding process, material, and material thickness, either a tension test or a peel test as shown in Figure HW-745, sketch (f),

(23)

**Figure HW-745
Two-Ply Joint Assemblies**

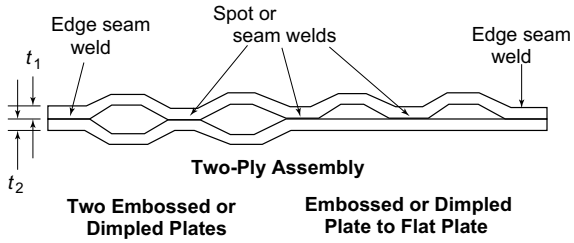

(a)

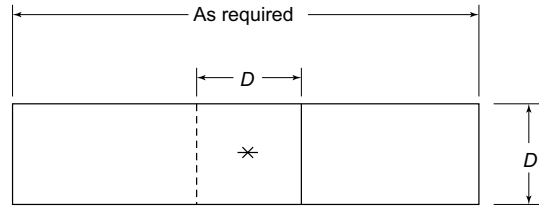

$1 \text{ in. (25 mm)} \leq D \leq 1\frac{1}{4} \text{ in. (32 mm)}$

(b) Single-Spot-Weld Tension Specimen, Two-Ply Joint

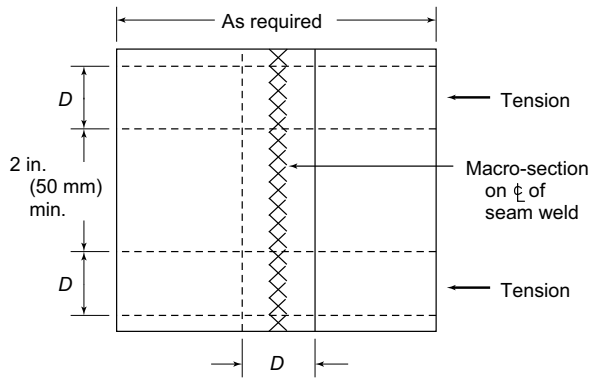

$1 \text{ in. (25 mm)} \leq D \leq 1\frac{1}{4} \text{ in. (32 mm)}$

(c) Seam-Weld Specimen for Tension and Macro-section, Two-Ply Joint

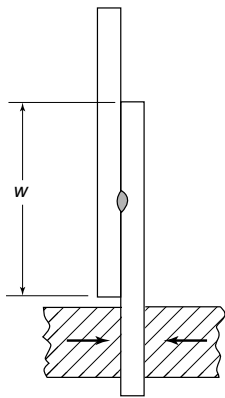
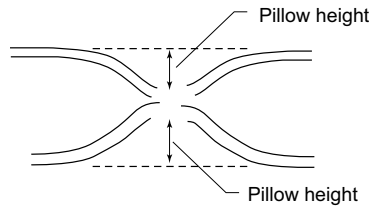
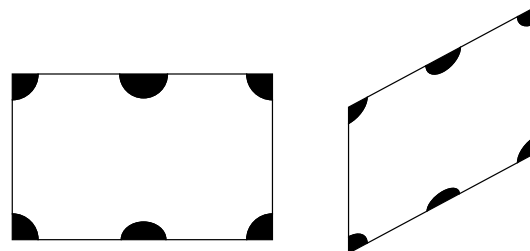

Step (1)

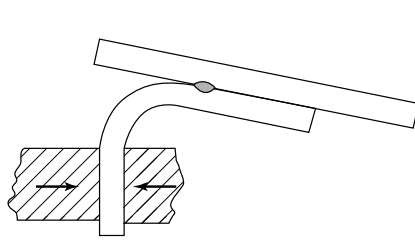

Step (2)

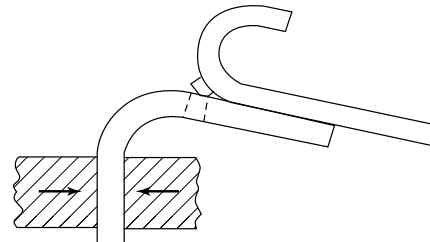

Step (3)

Step 1: Grip specimen in vise or other suitable device.

Step 2: Bend specimen (this step may not be required if the gripped portion of the specimen is greatly thicker than the other portion).

Step 3: Peel pieces apart with suitable tool until they are separated.

(f) Peel Test

shall be performed. The acceptance criterion for these tests shall be that the parent metal adjacent to the weld must fail before the weld itself fails.

(3) *Machine Settings and Controls.* The resistance welding machine settings and process control parameters used in the making of the proof test panel and the workmanship samples shall be recorded. Except for minor variations and adjustments as may be permitted at the discretion of the Inspector, the applicable settings shall be used in the fabrication of all panels in a given production run.

(4) *Pressure Tests and Inspection.* All production boilers shall be pressure tested to a pressure not less than 1.5 times the allowable working pressure. These tests and inspection during fabrication shall be in accordance with HG-510, except that provisions of HG-510(b) may be exceeded because the application of pressure during formation of the pillows will exceed the design and test pressure by more than the allowed 10 psi (70 kPa).

(5) *Records.* Records shall be kept of all data obtained from tests of the proof test boiler or panel, duplicate test panel, the workmanship samples, the welding machine settings, and the welding procedure and process control parameters. Records shall be kept of all preheat, postheat, and heat-treatment procedures and of inspection procedures.

(f) If spot and seam welding machines other than those used for the initial proof test panel, duplicate test panel, and workmanship samples are to be used in production,

each additional machine and welding procedure shall be qualified in accordance with (e)(2)(-a) and (e)(2)(-b) above.

(g) Lap joints only, between two thicknesses of metal sheet, may be resistance spot or seam welded. The use of projection welding (including resistance stud welding) is excluded.

(h) The range of thickness of sheet materials that may be resistance spot or seam welded shall be as follows for two-ply joints [see Figure HW-745, sketch (a)]:

(1) the minimum thickness t_1 or t_2 shall be 0.045 in. (1.14 mm)

(2) the maximum thickness t_1 or t_2 shall be $\frac{1}{4}$ in. (6 mm) nominal

(i) If arc welding, gas welding, or brazing are used for the attachment of nozzles, tubes, and fittings, for repair or for the closing of peripheral seams, the qualification of welding or brazing procedure and welding or brazing performance shall be conducted in accordance with the requirements of Section IX. Filler metals, if used, shall conform to the requirements of Section IX.

(j) For construction having sheets formed within dies where the dies control the shape of the pillow and restrain the spot welds so that the bending in the sheet is outside the heat-affected zone, the welding may be done before or after forming. The requirements and limitations in (d)(2) above do not apply to this method of construction.

ARTICLE 8

FABRICATION REQUIREMENTS

HW-800 FORMING PLATES

The ends of plates that form the longitudinal joints of boiler shells shall be formed by pressure, not sledging, to the proper curvature.

HW-801 BASE METAL PREPARATION

(a) The preparation of joints prior to welding may involve any of the conventional methods in use such as machining, thermal cutting, chipping, grinding, or combinations of these.

(b) Where thermal cutting is used, the effect on the mechanical and metallurgical properties of the base metal shall be taken into consideration.

(c) The method of base metal preparation used shall leave the welding groove with reasonably smooth surfaces and free from deep notches, striations, or irregularities. The surfaces for welding shall be free of all scale, rust, oil, grease, or other foreign materials.

(d) Cast surfaces to be welded shall be machined, chipped, or ground where necessary to remove foundry scale and to expose sound metal.

HW-810 ASSEMBLY

(a) Parts that are being welded shall be fitted, aligned, and retained in position during the welding operation within the tolerance specified in [HW-812](#).

(b) Bars, jacks, clamps, tack welds, or other appropriate means may be used to hold the edges of the parts to be welded in alignment.

(c) Tack welds used to secure alignment shall either be removed completely when they have served their purpose, or their stopping and starting ends shall be properly prepared by grinding or other suitable means so that they may be satisfactorily incorporated into the final weld. Tack welds, whether removed or left in place, shall be made using a fillet weld or butt weld procedure qualified in accordance with Section IX. Tack welds to be left in place shall be made by welders qualified in accordance with Section IX and shall be examined visually for defects, and if found defective shall be removed.

It is not necessary that a subcontractor performing such tack welds for the vessel manufacturer be a holder of an ASME Certificate of Authorization. If the tack welds are permanently left in place, the final vessel manufacturer

shall maintain the controls to assure that the necessary welding procedure and performance qualifications are met in order to satisfy Code requirements.

(d) When joining two parts by the inertia and continuous drive friction welding processes, one of the two parts must be held in a fixed position and the other part rotated. The two faces to be joined must be essentially symmetrical with respect to the axis of rotation. Some of the basic types of applicable joints are solid round to solid round, tube to tube, solid round to tube, solid round to plate, and tube to plate.

HW-812 ALIGNMENT TOLERANCE

(a) The edges of plates at butt joints shall not be offset from each other at any point in excess of the amount in the following table, where t is the plate thickness.

Plate Thickness, in. (mm)	Direction of Joints in Cylindrical Vessels	
	Longitudinal	Circumferential
Up to $\frac{1}{2}$ (13), incl.	$\frac{1}{4}t$	$\frac{1}{4}t$
Over $\frac{1}{2}$ to $\frac{3}{4}$ (13 to 19), incl.	$\frac{1}{8}$ in. (3.0 mm)	$\frac{1}{4}t$
Over $\frac{3}{4}$ (19)	$\frac{1}{8}$ in. (3.0 mm)	$\frac{3}{16}$ in. (5.0 mm)

(b) Butt joints in heads and butt joints between cylindrical shells and hemispherical heads shall meet the requirements in (a) above for longitudinal joints in cylindrical shells.

HW-813 DISTORTION

(a) The cylinder or barrel of a drum or shell shall be circular at any section within a limit of 1% of the mean diameter, based on the differences between the maximum and minimum mean diameters at any section, and if necessary to meet this requirement shall be reheated, rerolled, or reformed. To determine the difference in diameters, measurements may be made on the inside or the outside. For vessels with longitudinal lap joints, the permissible difference in inside diameters may be increased by the nominal plate thickness.

(b) Cylindrical furnaces and other cylindrical parts subjected to external pressure shall be rolled to a circle with a maximum permissible deviation from the true circle of not more than $\frac{1}{4}$ in. (6 mm).

HW-820 SPECIFIC WELDING REQUIREMENTS

(23) **HW-820.1 Finished Longitudinal and Circumferential Joints.** Butt-welded joints shall have complete penetration and full fusion. The surface of the weld may be left as-welded provided the weld is free of coarse ripples, grooves, overlaps, abrupt ridges, or valleys. A reduction in thickness due to the welding process is acceptable provided all of the following conditions are met:

(a) The reduction in thickness shall not reduce the material of the adjoining surfaces below the minimum required thickness at any point.

(b) The reduction in thickness shall not exceed $\frac{1}{32}$ in. (0.8 mm) or 10% of the nominal thickness of the adjoining surface, whichever is less.²³

HW-820.2 Fillet Welds. In making fillet welds, the weld metal shall be deposited in such a way that adequate penetration into the base metal at the root of the weld is secured. The reduction of the thickness of the base metal due to the welding process at the edges of the fillet weld shall meet the same requirements as for butt welds [see [HW-820.1](#)].

HW-820.3 Double-Welded Butt Joints. Before applying weld metal on the second side to be welded, the root of double-welded butt joints shall be prepared by suitable methods such as chipping, grinding, or thermal gouging, so as to secure sound metal at the base of weld metal deposited on the face side, except for those processes of welding by which proper fusion and penetration are otherwise obtained and by which the root of the weld remains free from impurities.

HW-820.4 Stud Welding. In the case where arc stud welding and resistance stud welding is used to attach load carrying studs, a production stud weld test of the procedure and welding operator shall be performed on five studs, welded and tested in accordance with either the bend or torque stud weld testing described in Section IX as follows:

(a) prior to start of daily operation if used continuously on units of similar construction

(b) prior to the start of application to a given unit when not used continuously

(c) after adjustment or servicing is done on welding equipment

HW-820.5 Procedure and Performance Qualification Tests and Material Requirements for Stud Welding. Procedure and performance qualification tests for stud welds shall be made in accordance

with Section IX. Further requirements for stud welding are as follows.

(a) Metallic coatings (such as cadmium plating) if used shall not be within $\frac{1}{2}$ in. (13 mm) from the weld end of the stud.

(b) The base metal must be above 50°F (10°C) during the welding process.

HW-820.6 Stud Welding. When stud welding and resistance stud welding are used for joining nonpressure-bearing attachments, which have essentially no load-carrying function [such as extended heat transfer surfaces and insulation attachment pins, except as provided in [HW-840\(b\)](#)], to pressure parts by an automatic welding process performed in accordance with a Welding Procedure Specification (in compliance with Section IX as far as applicable), procedure and performance qualification testing is not required.

When stud welding is used to attach nonload-carrying studs, a production stud weld test, appropriate to the end use application requirements, shall be specified by the Manufacturer or Assembler and carried out on a separate test plate or tube

(a) prior to the start of daily operation if used continuously on units of similar construction

(b) prior to the start of application to a given unit when not used continuously

(c) after adjustment or servicing is done on welding equipment

HW-820.7 The welded joint between two members joined by the inertia and continuous drive friction welding processes shall be a full penetration weld. Visual examination of the as-welded flash roll of each weld shall be made as an in-process check. The weld upset shall meet the specified amount within $\pm 10\%$. The flash shall be removed to sound metal.

HW-820.8 Welding (Brazing) by Non-Certificate Holders. Welders, including brazers, and welding and brazing operators not in the employ of the manufacturer (Certificate of Authorization Holders) may be used to fabricate boilers or parts thereof constructed in accordance with the Section, provided all of the following conditions are met:

(a) All Code construction shall be the responsibility of the Manufacturer.

(b) All welding shall be performed in accordance with the Manufacturer's welding procedure specifications which have been qualified by the Manufacturer in accordance with the requirements of Section IX and this Section.

(c) All welders shall be qualified by the Manufacturer in accordance with the requirements of Section IX and this Section.

(d) The Manufacturer's quality control system shall include as a minimum the following:

(1) a requirement for complete and exclusive administrative and technical supervision of all welders by the Manufacturer

(2) evidence of the Manufacturer's authority to assign and remove welders at his discretion without involvement of any other organization

(3) a requirement for Assignment of Welder Identification symbols

(4) evidence that this program has been accepted by the Manufacturer's Authorized Inspection Agency which provides the inspection service

(e) The Manufacturer shall be responsible for Code compliance of the completed boiler or part, including applying the Certification Mark with appropriate designator and providing Manufacturer's Data Reports properly completed and certified by the Inspector.

HW-820.9 Flash Welding. If tube butt welds are made using the flash welding process, production testing shall be performed in accordance with Section IX, QW-199.7.3 as follows:

(a) one example shall be tested at the start of production

(b) one sample shall be tested at the beginning, midpoint, and end of each work shift

(c) when production shifts are consecutive, a test at the end of the shift may serve as the test for the beginning of the next shift

(d) when a welding operator is replaced during production

(e) if any machine's settings are changed

When any production run weld fails to pass the required tests, the welding parameters shall be adjusted until two consecutive welds pass the bend test. In addition, all welds that were made subsequent to the previous successful test shall be either cut out and rewelded or cut out and tested in reverse sequence of welding until two successive welds pass the tests.

HW-830 REPAIR OF WELD DEFECTS

Visible defects, such as cracks, pinholes and incomplete fusion, and defects detected by leakage tests shall be removed by mechanical means or by thermal grooving processes, after which the joint shall be rewelded and reexamined.

HW-840 POSTHYDROTEST WELDING OF NONPRESSURE PARTS TO PRESSURE PARTS

(a) Nonpressure parts, other than insulation attachment pins welded by the capacitive discharge method, may be welded to pressure parts after the hydrostatic test has been performed in accordance with the requirements as set forth in [HG-510](#), provided the following criteria are met.

(1) The welding is done in accordance with this Subpart (see [HW-820](#)).

(2) The material requirements shall comply as follows:

(-a) The pressure part material is limited to P-No. 1, Group 1 or 2 materials.

(-b) The nonpressure attachment material is limited to carbon steel with a carbon content not exceeding 0.20% or any P-No. 1 material.

(-c) When the nonpressure attachment material is other than P-No. 1, a minimum 200°F (93°C) preheat shall be applied when the pressure part thickness exceeds $\frac{3}{4}$ in. (19 mm).

(3) The attachment is done by stud welding or with fillet welds where the throat of the weld is not to exceed the lesser of 1.5 times the thickness of the pressure part or $\frac{1}{4}$ in. (6 mm).

(4) The completed weld is inspected by the Authorized Inspector.

(5) The Manufacturer's Data Report Form shall be signed only after completion of the welding.

(6) Welding is not permitted on brazed joints.

(b) Insulation attachment pins may be stud welded to pressure parts after the hydrostatic test without requiring inspection by the Authorized Inspector and without requiring a production stud weld test, provided the following conditions are met.

(1) Insulation attachment pins shall have a nominal diameter not exceeding 50% of the plate thickness or $\frac{3}{16}$ in. (5.0 mm), whichever is less.

(2) Capacitive discharge welding process shall be used.

(3) The procedure shall be included in the Manufacturer's Quality Control Manual, and the Authorized Inspector shall have the opportunity to monitor the process.

(4) The insulation attachment pins shall be installed prior to application of the Certification Mark and the signing of the Manufacturer's Data Report.

ARTICLE 9 INSPECTION

HW-900 INSPECTION DURING FABRICATION

The manufacturer shall submit the boiler or other pressure part for inspection at such stages of the work as may be designated by the Inspector.

HW-910 CHECK OF WELDING PROCEDURE QUALIFICATIONS

(a) It is the duty of the Inspector to assure himself that the welding procedures employed in construction have been qualified under the provisions of Section IX. The manufacturer shall submit evidence to the Inspector that those requirements have been met.

(b) The Inspector has the right at any time to call for and witness the test welding and testing, although it is not mandatory that he witness the test welding and the testing unless he so desires.

HW-911 CHECK OF WELDER AND WELDING OPERATOR PERFORMANCE QUALIFICATIONS

(a) It is the duty of the Inspector to assure himself that all welding is done by welders or welding operators qualified under the provisions of Section IX. The manufacturer shall make available to the Inspector a certified copy of the record of performance qualification tests of each welder and welding operator as evidence that these requirements have been met.

(b) The Inspector has the right at any time to call for and witness the test welding and testing, although it is not mandatory that he witness the test welding and the testing unless he so desires.

PART HF — SUBPART HB

REQUIREMENTS FOR BOILERS FABRICATED BY BRAZING

ARTICLE 10

GENERAL REQUIREMENTS

HB-1000 SCOPE

The requirements of this [Subpart HB](#) are applicable to boilers and parts thereof that are fabricated by brazing.

qualify the brazing procedures he uses in the construction of the brazed assemblies built under Section IV and the performance tests of brazers and brazing operators to determine their ability to apply the procedure properly.

HB-1001 RESPONSIBILITY OF MANUFACTURER OR CONTRACTOR

Each manufacturer or contractor is responsible for the brazing done by his organization and shall establish the procedures and conduct the tests required in Section IX to

ARTICLE 11

MATERIAL REQUIREMENTS

HB-1100 GENERAL

Materials used in the construction of boilers and parts thereof by brazing shall conform to the specifications in Section II, and shall be limited to those materials for which allowable stress values have been assigned in Section II, Part D, Table 6A or Table 6B. The materials being brazed shall be of proved brazing quality with the brazing filler metal employed. Satisfactory qualification of the brazing procedure under Section IX is considered proof of acceptable material for brazed construction.

HB-1101 COMBINATIONS OF DISSIMILAR MATERIALS

Combinations of dissimilar metals may be joined by brazing provided they meet the qualification requirements of Section IX.

HB-1102 BRAZING FILLER METALS

The selection of the brazing filler metal for a specific application shall depend upon its suitability for the base metals being joined. Satisfactory qualification of the brazing procedure under Section IX is considered proof of the suitability of the filler metal. Brazing used with brazing filler metals other than those listed in Section II, Part C, SFA-5.8 shall be separately qualified for both procedure and performance qualification in accordance with Section IX.

HB-1103 FLUXES AND ATMOSPHERES

Suitable fluxes or atmospheres or combinations of fluxes and atmospheres shall be used to prevent oxidation of the brazing filler metal and the surfaces to be joined. Satisfactory qualification of the brazing procedure under Section IX is considered proof of the suitability of the flux and/or atmosphere.

ARTICLE 12

BRAZING PROCESSES, PROCEDURES, AND QUALIFICATIONS

HB-1200 BRAZING PROCESSES

Specific brazing processes which are permitted for use under this Section are classified by method of heating and are torch brazing, furnace brazing, induction brazing, electrical resistance brazing, and dip brazing — salt and flux bath.

HB-1201 JOINT BRAZING PROCEDURES

A joint brazing procedure shall be developed for each different type of joint of a brazed assembly. A recommended form for recording the brazing procedure is shown in Section IX, QB-480. If more than one joint occurs in a brazed assembly, the brazing sequence shall be specified on the drawing or in instructions accompanying the drawing. If welding and brazing are to be done on the same assembly, the welding shall precede the brazing unless it is determined that the heat of welding will not adversely affect the braze previously made, and the weld will not be adversely contaminated by the brazing metal.

HB-1202 BRAZING QUALIFICATIONS AND RECORDS

HB-1202.1 Qualification of Brazing Procedures.

(a) Each brazing procedure employed in the fabrication of boilers shall be qualified in accordance with Section IX. Only qualified procedure specifications shall be followed in construction. Each manufacturer shall conduct the required tests to qualify all brazing procedures to be used by his organization.

(b) The nominal thickness of base material used with lap joints tested using the test fixture shown in Section IX, QB-463.7 shall not exceed $\frac{1}{2}$ in. (13 mm). There is no thickness limitation when specimens are tested without the test fixture shown in Section IX, QB-463.7.

HB-1202.2 Qualification of Brazers and Brazing Operators. All brazers assigned to manual brazing shall have passed the tests prescribed for brazers in Section IX. All brazing operators assigned to brazing by automatic means or by furnace, induction, resistance, or dip brazing shall pass the tests as prescribed in Section IX. Such tests shall be conducted by the manufacturer or contractor.

HB-1202.3 No Production Work Without Qualifications. No production work shall be undertaken until both the brazing procedure and the brazers or brazing operators have been qualified.

HB-1202.4 Maintenance of Records of Qualifications and Identifying Marks.

(a) The manufacturer shall maintain qualification records of the brazers and brazing operators employed by him showing the date and results of qualifying tests and the identifying mark assigned to each. These records shall be certified to by the Manufacturer by signature or some other method of control in accordance with the Manufacturer's quality control system, and shall be accessible to the Inspector.

(b) Each brazer and brazing operator so qualified shall be assigned an identifying number, letter, or symbol by the manufacturer which shall be used to identify the work of that brazer or brazing operator.

ARTICLE 13 DESIGN

HB-1300 STRENGTH OF BRAZED JOINTS

(a) It is the responsibility of the designer to determine from suitable tests or from past experience that the specific brazing filler metal selected can produce a joint which will have adequate strength over the operating temperature range. The strength of the brazed joint shall not be less than the strength of the base metal, or the weaker of the two base metals in the case of dissimilar metal joints.

(b) For any type of joint, the strength of the brazed section shall exceed that of the base metal portion of the test specimen in the qualification tension tests provided for in Section IX, QB-150. Lap joints shall have a sufficient overlap to provide a higher strength in the brazed joint than in the base metal.

HB-1301 BRAZED JOINT EFFICIENCY FACTORS

(a) The joint efficiency factor to be used in design of boilers with brazed joints shall be 0.80 for joints in which visual examination assures that the brazing filler metal has penetrated the entire joint.

(b) The joint efficiency factor to be used in the design of boilers shall be 0.50 for joints in which visual examination will not provide proof that the brazing filler metal has penetrated the entire joint.

HB-1302 MINIMUM THICKNESS

The minimum thickness of nonferrous and other copper or copper-alloy plates, heads, and tubesheets shall be as specified in [HF-301](#).

HB-1303 PERMISSIBLE SERVICE TEMPERATURE

Satisfactory qualification of the brazing procedure in accordance with Section IX, Part QB is considered satisfactory proof of the adequacy of the base materials, the brazing filler metal, the flux and/or atmosphere, and other variables of the procedure for service not exceeding 250°F (120°C).

HB-1304 APPLICATION OF BRAZING FILLER METAL

The design shall provide for the application of the brazing filler metal as part of the design of the joint. Where practicable, the brazing filler metal shall be applied in such a manner that it will flow into the joint or be distributed across the joint and produce visible evidence that it has penetrated the joint.

(a) *Manual Application.* The manual application of the brazing filler metal by face-feeding to a joint should be from one side only. Visual observation of the other side of the joint will then show if the required penetration of the joint by the filler metal has been obtained. If the side opposite to the filler metal application cannot be visually examined, as is the case with socket-type joints in pipe and tubing (blind joint), a joint efficiency factor of 0.50 shall be used in design of this joint.

(b) *Preplaced Brazing Filler Metal.* The brazing filler metal may be preplaced in the form of slugs, powder, rings, strip, cladding, spraying, or other means. After brazing, the brazing filler metal should be visible on both sides of the joint. If the brazing filler metal is preplaced within a blind joint in such a manner that it penetrates the major portion of the joint during brazing and appears at the visible side of the joint, a joint efficiency factor of 0.80 may be used in the design of the joint. If the brazing filler metal is preplaced on the outside or near the outside of a blind joint, and the other side cannot be inspected to ascertain complete penetration, then a joint efficiency factor of 0.50 shall be used in the design of the joint.

HB-1305 JOINT CLEARANCE

(a) The joint clearance shall be kept sufficiently small so that the filler metal will be distributed by capillary attraction. Since the strength of a brazed joint tends to decrease as the joint clearance used is increased, the clearances for the assembly of joints in boilers shall be within the tolerances set up by the joint design and as used for the corresponding qualification specimens made in accordance with Section IX.

(b) If greater tolerances are to be used in production, the joint must be requalified for those greater tolerances. The control of tolerances required may be obtained by using rivets, spot welding, crimping, or other means

Table HB-1305
Recommended Joint Clearances at Brazing
Temperature

Brazing Filler Metal	Clearance, in. (mm)
B Al Si Group	0.006–0.010 (0.15–0.25) for laps < ¼ in. (6.35) 0.010–0.025 (0.25–0.64) for laps > ¼ in. (6.35)
B CuP Group	0.001–0.005 (0.02–0.12)
B Ag Group	0.002–0.005 (0.05–0.12)
B Cu Zn Group	0.002–0.005 (0.05–0.12)
B Cu Group	0.000–0.002 (0.00–0.05)

which will not interfere with the quality of the braze. If such means are employed in production, they must also be employed in qualification of procedure, brazer, and operator.

NOTE: For guidance, see [Table HB-1305](#), which gives recommended joint clearances at brazing temperature for various types of brazing filler metal. Brazing alloys will exhibit maximum unit strength if clearances are maintained within these limits.

HB-1306 OPENINGS

(a) Openings for nozzles and other connections shall be far enough away from any main brazed joint so that the joint and the opening reinforcement plates do not interfere with one another.

(b) Openings for pipe connections in boilers having brazed joints may be made by inserting pipe couplings, not exceeding NPS 3 (DN 80), or similar devices in the shell or heads and securing them by welding, provided the welding is performed by welders who have been qualified under the provisions of Section IX for the welding position and type of joint used. Such attachments shall conform to the rules for welded connections.

HB-1307 BRAZED CONNECTIONS

(a) Connections, such as saddle type fittings and fittings inserted into openings formed by outward flanging of the vessel wall, in sizes not exceeding NPS 3 (DN 80), may be attached to boilers by lap joints of brazed construction. Sufficient brazing shall be provided on either side of the line through the center of the opening parallel to the longitudinal axis of the shell to develop the strength of the reinforcement through shear in the brazing.

(b) For nozzle fittings having a bolting flange and an integral flange for brazing, the thickness of the flange attached to the boiler shall not be less than the thickness of the neck of the fitting.

ARTICLE 14 FABRICATION REQUIREMENTS

HB-1400 CLEANING OF SURFACES TO BE BRAZED

The surfaces to be brazed shall be clean and free from grease, paint, oxides, scale, and foreign matter of any kind. Any chemical or mechanical cleaning method may be used that will provide a surface suitable for brazing.

HB-1401 POSTBRAZING OPERATIONS

Brazed joints shall be thoroughly cleaned of flux residue by any suitable means after brazing and prior to inspection.²⁴ Other postbrazing operations such as thermal treatments shall be performed in accordance with the qualified procedure.

HB-1402 REPAIR OF DEFECTIVE BRAZING

Brazed joints which have been found to be defective may be rebrazed, where feasible, after thorough cleaning, and by employing the same brazing procedure used for the original braze. If a different brazing procedure is employed i.e., torch repair of furnace brazed parts, a repair brazing procedure shall be established and qualified.

When a repair brazing procedure is established it shall provide control of the application of brazing filler metal to meet the conditions set forth in [HB-1301\(a\)](#). Where these requirements cannot be met, the limitations of [HB-1301\(b\)](#) will apply.

ARTICLE 15

INSPECTION AND MARKING

HB-1500 INSPECTION

HB-1501 Inspection of Brazing Procedure

The Inspector shall examine the procedure for each type of joint being produced and shall determine that the procedure has been qualified in accordance with the requirements of Section IX and shall satisfy himself that fabrication of the joint is in accordance with the procedure. Where there is evidence of consistent poor quality, the Inspector shall have the right at any time to call for and witness tests of the brazing procedure.

HB-1502 Certification of Brazer and Brazing Operator

(a) The manufacturer shall certify that the brazing on a vessel or part thereof has been done by brazers or brazing operators who are qualified under the requirements of Section IX, and the Inspector shall assure himself that only qualified brazers or brazing operators have been used.

(b) The manufacturer shall make available to the Inspector a certified copy of the record of the qualification tests of each brazer and brazing operator. The Inspector shall have the right at any time to call for and witness tests of the ability of a brazer or brazing operator.

HB-1503 Visual Examination

(a) Where possible, both sides of each brazed joint shall be visually examined after flux residue removal. Where it is not possible to inspect one side of a brazed joint (blind joint), the Inspector shall check the design to determine that the proper joint factor has been employed, unless he can assure himself that the brazing filler metal has been preplaced in such a manner that it satisfied [HB-1304](#).

(b) There shall be evidence that the brazing filler metal has penetrated the joint. In a butt braze there shall be no concavity. The braze may be repaired or rebrazed.

(c) The presence of a crack in the brazing filler metal shall be cause for rejection. Dye penetrant inspection may be used if desired. The braze may be repaired or rebrazed.

(d) The presence of a crack in the base metal adjacent to a braze shall be cause for rejection even if the crack is filled with brazing alloy. Such cracking shall not be repaired.

(e) Visible pinholes or open defects in the braze shall be cause for rejection. The joint may be rebrazed.

(f) Rough fillets, particularly those with a convex appearance, are cause for rejection. Such joints may be repaired or rebrazed.

HB-1510 Marking

Boilers shall be marked according to the requirements of [HG-530](#) or the marking may be placed on a nonferrous plate, irremovably attached to a visible part of the boiler.

PART HC REQUIREMENTS FOR BOILERS CONSTRUCTED OF CAST IRON

ARTICLE 1 GENERAL

HC-100 SCOPE

The rules in [Part HC](#) are applicable to heating boilers that are constructed primarily of cast iron sections, and shall be used in conjunction with general requirements of [Part HG](#) of this Section.

ARTICLE 2

MATERIAL REQUIREMENTS

HC-200 GENERAL MATERIAL REQUIREMENTS

(a) All materials used for cast sections of boilers that are constructed primarily of cast iron shall meet the requirements of this Article for gray iron castings.

(b) External appurtenances, such as cast or welded headers and other miscellaneous pressure parts, shall be manufactured under Part [HC](#) or [HF-203](#). The design pressure for these pressure parts for which the strength cannot be computed shall be established in accordance with [HG-500](#).

HC-201 MANUFACTURE

The melting procedure shall be optional with the Manufacturer.

HC-202 CHEMICAL COMPOSITION

Drillings taken from test ingots, broken test specimens, or from castings, shall conform to the following as to chemical composition.

(a) The manganese shall be controlled as required to meet $Mn \geq (1.7 \times S) + 0.2$, where Mn is percent manganese and S is percent sulfur.

(b) The phosphorous content shall not exceed 1.00%.

HC-203 TENSILE STRENGTH CLASSIFICATION

Castings shall be known and listed by classes according to the minimum requirements as to tensile strengths of test bars, specified as follows:

Class No.	Tensile Strength Min., psi (MPa)
20	20,000 (140)
25	25,000 (170)
30	30,000 (200)
35	35,000 (240)
40	40,000 (275)

HC-204 TEST BARS

Test bars shall be cast separately from the castings (see [HC-206](#)). The sizes of cast test bars shall be as determined in [HC-205](#). Tension specimens shall be machined from those castings to the dimensions shown in

[Figure HC-204.1](#). Tension test specimens “cast to size” shall not be used. The test bar castings shown in [Figure HC-205.1](#) may be used for optional transverse tests, when that test is specified.

HC-205 SELECTION OF TEST BAR SIZE

The dimensions of the test bars as shown in [Figure HC-205.1](#) shall be determined by the thickness of the controlling section of the casting as follows (the body or shell of the casting shall be the controlling section):

Thickness of Controlling Section of Casting, in. (mm)	Test Bar
0.5 (13) and under	A
0.51 to 1.00 (13.0 to 25)	B
Over 1.00 (25)	C

HC-206 MOLDING AND POURING TEST BARS

Test bars shall be made under the same sand conditions as the castings. The bars shall be poured from the same ladles of iron used to pour the castings. The test bars shall receive the same thermal treatment as the castings. Thermal treatment involving a liquid quench from above the critical range is not permitted for castings covered in this Article.

HC-207 NUMBER OF TESTS

(a) For purposes of this requirement, a melting period shall not exceed 24 hr.

(b) For tensile or transverse tests for each class of iron, one or more test bars shall be cast during each 4 hr period during the melt. No less than two test bars are to be cast from each melt, one during the first half of the melting period, and the other during the last half of the melting period. For chemical composition test samples, see [HC-202](#).

(c) During each 8 hr period, one chemical composition test and either one tensile or one transverse test shall be made on each melt (or each mixture if two or more mixtures of a different class of iron are made in a given melt) for each controlling section (see [HC-205](#)) in the castings made from each melt (or mixture).²⁵

**Figure HC-204.1
Dimensions of Tensile Test Specimen**

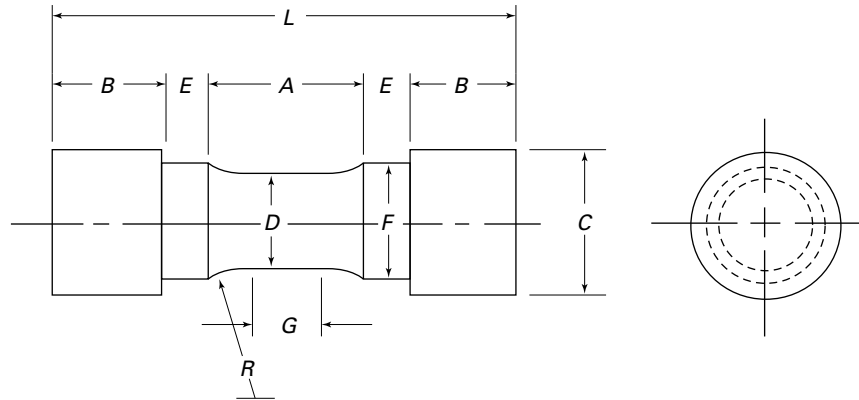

Legend:

- A = length of reduced section
- B = length of end section
- C = diameter of end section
- D = diameter
- E = length of shoulder
- F = diameter of shoulder
- G = length of parallel
- L = overall length
- R = radius of fillet

Test Bar	Dimensions, in. (mm)								
	Min. A	B	Approx. C	D	Min. E	F	Min. G	Min. L	Min. R
A	1 ¹ / ₄ (32)	[Note (1)]	³ / ₄ (19)	0.500 ± 0.010 (13 ± 0.25)	¹ / ₄ (6)	⁵ / ₈ ± ¹ / ₆₄ (16 ± 0.4)	0.50 (13)	3 ³ / ₄ (95)	1 (25)
B	1 ¹ / ₂ (38)	[Note (1)]	1 ¹ / ₈ (29)	0.750 ± 0.015 (19 ± 0.38)	¹ / ₄ (6)	¹⁵ / ₁₆ ± ¹ / ₆₄ (24 ± 0.4)	0.75 (19)	4 (100)	1 (25)
C	2 ¹ / ₄ (57)	[Note (1)]	1 ⁷ / ₈ (48)	1.25 ± 0.025 (32 ± 0.63)	⁵ / ₁₆ (8)	1 ⁷ / ₁₆ ± ¹ / ₆₄ (37 ± 0.4)	1.25 (32)	6 ³ / ₈ (160)	2 (51)

NOTE: (1) Optional to fit holders on testing machine. If threaded, root diameter shall not be less than dimension F.

HC-208 TENSION TEST

The tension test shall be considered the primary test for qualification under this Article. The results of the tension or transverse tests shall determine compliance for the various classes given in [HC-203](#) (see [HC-210](#), Retests.)

HC-209 TENSION TEST PROCEDURE

Tension test specimens ([Figure HC-204.1](#)) shall fit the holders of the testing machine in such a way that the load shall be axial. The use of self-aligning shackles is recommended.²⁶ After reaching a stress equivalent to 15,000 psi (100 MPa), the speed of the moving head of the testing machine shall not exceed 0.125 in./min (3.18 mm/min). The minimum tensile strength shall be as specified in [HC-203](#) (see [HC-210](#)).

HC-210 TENSION RETESTS

(a) If any test specimen shows defective machining or obvious lack of continuity of metal, it shall be discarded and replaced by another specimen.

(b) In no case shall the actual tensile strength of the tension specimen be more than 10% under the minimum tensile strength listed in [HC-203](#). If it is, the casting(s) shall be rejected.

(c) If the actual tensile strength of the tension specimen is not more than 10% under the minimum tensile strength listed in [HC-203](#), two more tension specimens may be tested. The arithmetical average tensile strength, psi (MPa), of the three tension specimens shall equal or exceed the minimum tensile strength specified in [HC-203](#) for the casting(s) to be accepted.

Figure HC-205.1
Cast Test Bars

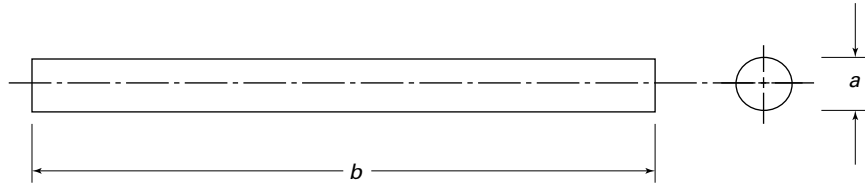

Test Bar	Diameter a , in. (mm)	Dimensions Length, b , in. (mm) [Note (1)]	Distance Between Supports in Transverse Test, in. (mm)	Permissible Variations, in. (mm)
A	0.875 (22)	15 (380)	12 (300)	± 0.05 (± 1.3)
B	1.20 (30)	21 (530)	18 (460)	± 0.10 (± 2.5)
C	2.00 (50)	27 (680)	24 (600)	± 0.10 (± 2.5)

GENERAL NOTE: Test bars shall be plain, cylindrical shapes as shown. Where bars are cast on end, allowance for draft may be made. However, the diameter at the center of the length must correspond to the normal diameter, within the permissible variations.

NOTE: (1) If only tensile strength are specified, dimensions b may be reduced to the minimum length shown in [Figure HC-204.1](#).

(23) HC-211 TRANSVERSE TEST

Except for the tension tests required in [HC-402.2](#), the Manufacturer may waive the tension test specified in [HC-208](#) and use the transverse test. When used, the minimum breaking load, prescribed as follows, shall apply (see [HC-213](#)):

Class No.	Minimum Breaking Load, lb (kg)		
	Test Bar A 0.875 in. (22 mm) Diam., 12 in. (300 mm) Supports, lb (kg)	Test Bar B 1.20 in. (30 mm) Diam., 18 in. (450 mm) Supports, lb (kg)	Test Bar C 2.00 in. (50 mm) Diam., 24 in. (600 mm) Supports, lb (kg)
20	900 (400)	1,800 (800)	6,000 (2700)
25	1,025 (450)	2,000 (900)	6,800 (3000)
30	1,150 (500)	2,200 (1000)	7,600 (3400)
35	1,275 (550)	2,400 (1100)	8,300 (3700)
40	1,400 (600)	2,600 (1200)	9,100 (4100)

HC-212 TRANSVERSE TEST PROCEDURE

(a) The transverse test shall be made on the bar as cast, or as skin machined (provided in the latter case that the diameter is not reduced below the minimum sizes given in [Table HC-212](#)) with central loading between supports. Corrections shall be made for sizes of round bars as shown in [Table HC-212](#). In case of slightly elliptical bars (maximum and minimum diameters both within the tolerances given in [Table HC-212](#)), loading shall be on the minimum diameter, and the correction factor shall be obtained as follows: Square the depth of the bar measured at the point of application of the original load, multiply by the width, and divide the product by the cube of the diameter of the standard or nominal

size bar. A bar whose diameters (maximum and minimum) vary by more than 0.025 in. (0.60 mm) for the 0.875 in. (22 mm) diameter nominal size, or by more than 0.050 in. (1.25 mm) for the 1.2 in. (30 mm) and 2.0 in. (50 mm) diameter nominal sizes, respectively, shall be considered a slightly elliptical bar.

(b) In all cases, controlling dimensions shall be the diameter of the bar at fracture.

(c) The rate of application of the load shall be such that fracture is produced in not less than 15 sec for the 0.875 in. (22 mm) diameter bar, 20 sec for the 1.2 in. (30 mm) diameter bar, and 40 sec for the 2.0 in. (50 mm) diameter bar.

HC-213 TRANSVERSE RETESTS

(a) If any test specimen shows defective machining or obvious lack of continuity of metal, it shall be discarded and replaced by another specimen.

(b) In no case shall the breaking load of the transverse test bar be more than 10% under the minimum breaking load listed in [HC-211](#). If it is, the casting(s) shall be rejected.

(c) If the breaking load of the transverse test bar is not more than 10% under the minimum breaking load listed in [HC-211](#), a retest may be made. If the retest fails, the casting(s) shall be rejected, except as provided for in (d).

(d) When the transverse test bar fails to meet the minimum breaking load listed in [HC-211](#), the Manufacturer shall have the right to have tension test specimens machined from the broken ends of the transverse test bar. If the arithmetical average tensile strength, psi (MPa), of the tension specimens equal or exceed the minimum tensile strength specified in [HC-203](#), the castings are accepted.

**Table HC-212
Correction Factors for Transverse Test Bars**

Test Bar A 0.875 in. (22 mm) in Diameter			Test Bar B 1.20 in. (30 mm) in Diameter			Test Bar C 2.000 in. (50 mm) in Diameter		
Diameter of Test Bars, in. (mm)	Correction Factor		Diameter of Test Bars, in. (mm)	Correction Factor		Diameter of Test Bars, in. (mm)	Correction Factor	
	Load	Deflection		Load	Deflection		Load	Deflection
0.825 (20.96)	0.838	1.061	1.10 (27.94)	0.770	1.091	1.90 (48.26)	0.857	1.053
0.830 (21.08)	0.853	1.054	1.11 (28.19)	0.791	1.081	1.91 (48.51)	0.871	1.047
0.835 (21.21)	0.869	1.048	1.12 (28.45)	0.813	1.071	1.92 (48.77)	0.885	1.042
0.840 (21.34)	0.885	1.042	1.13 (28.70)	0.835	1.062	1.93 (49.02)	0.899	1.037
0.845 (21.46)	0.900	1.036	1.14 (28.96)	0.857	1.053	1.94 (49.28)	0.913	1.032
0.850 (21.59)	0.916	1.029	1.15 (29.21)	0.880	1.043	1.95 (49.53)	0.927	1.026
0.855 (21.72)	0.933	1.023	1.16 (29.46)	0.903	1.034	1.96 (49.78)	0.941	1.021
0.860 (21.84)	0.949	1.017	1.17 (29.27)	0.927	1.026	1.97 (50.04)	0.955	1.015
0.865 (21.97)	0.966	1.012	1.18 (29.97)	0.951	1.017	1.98 (50.29)	0.970	1.010
0.870 (21.10)	0.983	1.006	1.19 (30.23)	0.975	1.009	1.99 (50.55)	0.985	1.005
0.875 (22.23)	1.000	1.000	1.20 (30.48)	1.000	1.000	2.00 (50.80)	1.000	1.000
0.880 (22.35)	1.017	0.994	1.21 (30.73)	1.025	0.992	2.01 (51.05)	1.015	0.995
0.885 (22.48)	1.034	0.989	1.22 (30.99)	1.051	0.984	2.02 (51.31)	1.030	0.990
0.890 (22.61)	1.051	0.983	1.23 (31.24)	1.077	0.976	2.03 (51.56)	1.046	0.985
0.895 (22.73)	1.069	0.978	1.24 (31.50)	1.105	0.968	2.04 (51.82)	1.061	0.980
0.900 (22.86)	1.087	0.972	1.25 (31.75)	1.130	0.960	2.05 (52.07)	1.076	0.976
0.905 (22.99)	1.106	0.967	1.26 (32.00)	1.158	0.952	2.06 (52.32)	1.092	0.972
0.910 (23.11)	1.125	0.962	1.27 (32.26)	1.185	0.945	2.07 (52.58)	1.109	0.967
0.915 (23.24)	1.143	0.956	1.28 (32.51)	1.214	0.938	2.08 (52.83)	1.125	0.962
0.920 (23.37)	1.162	0.951	1.29 (32.77)	1.242	0.930	2.09 (53.09)	1.141	0.957
0.925 (23.50)	1.181	0.946	1.30 (33.02)	1.271	0.923	2.10 (53.34)	1.158	0.952

GENERAL NOTE: To correct to the standard diameter, divide the breaking load and deflection obtained in testing the bar by the respective correction factors.

HC-214 WORKMANSHIP, FINISH, AND REPAIR

(a) The surface of the casting shall conform substantially to the dimensions on drawings or to the dimensions predicated by the pattern, and be free from injurious defects. The surface of the casting shall be free from burnt-on sand and shall be reasonably smooth. Risers, fins, and projections used to facilitate the making of the casting shall be removed. In other respects, they shall conform to whatever requirements may be specially agreed upon between the Manufacturer and Purchaser.

(b) Seepage about chaplets, and minor leakage defects, may be repaired by peening or by plugging as directed below. Provided the surrounding metal is sound, a minor leak may be plugged with a solid cast iron tapered thread pipe plug. The maximum size of the pipe plug shall be 1 in. NPS (DN 25) and there shall be no less than four full standard pipe threads in the section metal (see [Table HC-214.](#))

(c) Welding shall not be permitted.

HC-215 EXAMINATIONS AND TESTS

The Manufacturer shall be responsible for all examinations and tests. When requested by a Purchaser, the Manufacturer shall agree to permit a representative of the Purchaser to have entry, at the time while work under the contract of the Purchaser is being performed, to all parts of the Manufacturer’s works that concern the castings manufactured to the requirements of this Article. All examinations and tests shall be made at the place of the manufacture prior to shipment, unless otherwise specified and shall be so conducted as not to interfere unnecessarily with the operation of the works.

HC-216 TEST RECORDS

The Manufacturer shall record and retain all test results required by this Article for a period of at least 1 yr. The test results shall be readily identifiable with the casting represented by the test results.

Table HC-214
Pipe Plug Size for Minimum Wall Thickness

Pipe Plug, NPS (DN)	Minimum Wall Thickness for Four-Thread Engagement, in. (mm)
$\frac{1}{8}$ (-)	0.15 (3.8)
$\frac{1}{4}$ (-)	0.22 (5.6)
$\frac{3}{8}$ (10)	0.22 (5.6)
$\frac{1}{2}$ (15)	0.285 (7.2)
$\frac{3}{4}$ (20)	0.285 (7.2)
1 (25)	0.35 (8.9)

ARTICLE 3 DESIGN

HC-300 MAXIMUM ALLOWABLE STRESS VALUES

(a) Table HC-300 gives the maximum allowable stress values in tension for castings conforming to the class iron listed therein.

(b) The maximum allowable stress value in bending shall be $1\frac{1}{2}$ times that permitted in tension and the maximum allowable stress value in compression shall be two times that permitted in tension.

(c) Stress values in Table HC-300 shall be used in calculations employing the available formulas in Part HG when applicable to the geometry of the boiler or boiler parts. Where the design pressure cannot be calculated under the available formulas, then the design pressure of the part in question shall be established in accordance with the provisions of HC-400.

HC-301 BASIS FOR ESTABLISHING STRESS VALUES IN TABLE HC-300

In the determination of allowable stress values for pressure parts, the Committee is guided by successful experience in service, insofar as evidence of satisfactory performance is available. Such evidence is considered equivalent to test data where operating conditions are

Table HC-300
Maximum Allowable Stress Values in Tension for Cast Iron, ksi (MPa)

Spec. No. [Note (1)]	Class	Minimum Tensile Strength, ksi (MPa)	Maximum Allowable Design Stress Values in Tension, ksi (MPa)
	20	20.0 (140)	4.0 (28)
	25	25.0 (173)	5.0 (35)
	30	30.0 (207)	6.0 (41)
	35	35.0 (242)	7.0 (48)
	40	40.0 (276)	8.0 (55)

GENERAL NOTE: Multiply ksi by 1,000 to obtain psi (multiply MPa by 1 000 to obtain kPa).

NOTE: (1) Cast iron specifications shall comply with Part HC, Article 2.

known with reasonable certainty. In the evaluation of new materials, it is necessary to be guided to a certain extent by the comparison of test information with similar data on successful applications of similar materials.

At any temperature below the creep range, the allowable stresses are established at no higher than the lowest of the following:

(a) $\frac{1}{5}$ of the specified minimum tensile strength at room temperature

(b) $\frac{1}{5}$ of the tensile strength at temperature

HC-310 HEADS

HC-310.1 Heads With Pressure on Concave Side.

Heads with pressure on the concave side (plus heads) shall be designed in accordance with formulas in HG-305 using the maximum allowable stress value in tension from Table HC-300. Bolted flanges when cast integral with concave heads shall have dimensions that conform to ASME B16.1, Cast Iron Pipe Flanges and Flanged Fittings, Class 125 and Class 250, and may be used as part of a pressure vessel for pressures not exceeding the ANSI ratings at temperatures not exceeding 450°F (230°C).

HC-310.2 Heads With Pressure on Convex Side.

The thickness of heads with pressure on the convex side (minus heads) shall not be less than the thickness required in HC-310.1 for plus heads under the same pressure, nor less than 0.01 times the inside diameter of the head skirt.

HC-311 SPHERICALLY SHAPED COVERS

Circular cast iron spherically shaped covers with bolting flanges, similar to Figure HC-311, sketches (a), (b), and (c), shall be designed in accordance with the following, and shall also be subjected to the proof test provisions of HC-400.

(a) *Notations.* The symbols used in the formulas of this paragraph are defined as follows:

A = outside diameter of flange

B = inside diameter of flange

C = bolt circle diameter

L = inside spherical or crown radius

Figure HC-311
Spherically Shaped Covers With Bolting Flanges

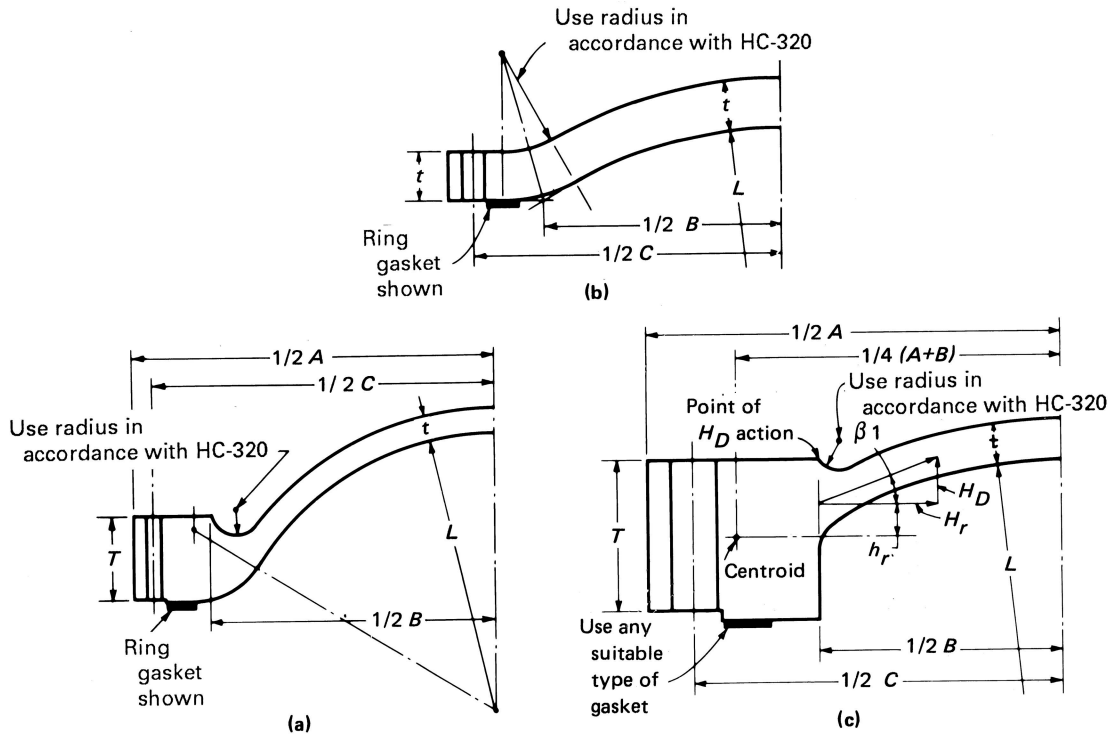

M_o = the total moment determined as in Section VIII, Division 1, Mandatory Appendix 2, 2-6, except that for heads of the type shown in Figure HC-311, sketch (c), a moment $H_r h_r$ (which may add or subtract) shall be included in addition to the moment $H_D h_D$ where

H_D = axial component of the membrane load in the spherical segment acting at the inside of the flange ring
 $= 0.785B^2P$

h_D = radial distance from the bolt circle to the inside of the flange ring

H_r = radial component of the membrane load in the spherical segment acting at the intersection of the inside of the flange ring with the center line of the dished cover thickness

$$= H_D \cot \beta_1$$

h_r = lever arm of force H_r about centroid of flange ring

P = design pressure for existing vessels

r = inside knuckle radius

S = maximum allowable stress value as given in Table HC-300

T = flange thickness

t = minimum required thickness of head plate after forming

β_1 = angle formed by the tangent to the center line of the dished cover thickness at its point of intersection with the flange ring, and a line perpendicular to the axis of the dished cover
 $= \arcsin [B/(2L + t)]$

NOTE: Since $H_r h_r$ in some cases will subtract from the total moment, the moment in the flange ring when the internal pressure is zero may be the determining loading for the flange design.

HC-311.1 Heads Concave to Pressure. Circular spherically dished heads with bolting flanges, concave to the pressure and conforming to the several types illustrated in Figure HC-311, shall be designed in accordance with the following formulas:

(a) Heads of the Type Shown in Figure HC-311, Sketch (a)

(1) Head thickness

$$t = \frac{5PL}{6S}$$

(2) Flange thickness T :

For ring gasket,

$$T = \sqrt{\frac{M_o}{SB} \left[\frac{A + B}{A - B} \right]}$$

For full-faced gasket,

$$T = 0.6 \sqrt{\frac{P}{S} \left[\frac{B(A + B)(C - B)}{A - B} \right]}$$

NOTE: The radial components of the membrane load in the spherical segment are assumed to be resisted by its flange. Within the range of ASME B16.1, the flange facings and drillings should conform to those standards and the thickness specified therein shall be considered as a minimum requirement.

(b) Heads of the Type Shown in [Figure HC-311](#), Sketch (b)

(1) Head thickness

$$t = \frac{SPL}{6S}$$

(2) Flange thickness for ring gaskets shall be calculated as follows:

(-a) For heads with round bolting holes,

$$T = Q + \sqrt{\frac{1.875M_o(C + B)}{SB(7C - 5B)}} \quad (1)$$

$$Q = \frac{PL}{4S} \left[\frac{C + B}{7C - 5B} \right] \quad (2)$$

(-b) For heads with bolting holes slotted through the edge of the head,

$$T = Q + \sqrt{\frac{1.875M_o(C + B)}{SB(3C - B)}} \quad (3)$$

$$Q = \frac{PL}{4S} \left[\frac{C + B}{3C - B} \right] \quad (4)$$

(3) Flange thickness for full-face gaskets shall be calculated by the following formula:

$$T = Q + \sqrt{Q^2 + \frac{3BQ(C - B)}{L}} \quad (5)$$

The value of Q in [eq. \(5\)](#) is calculated by [\(2\)\(-a\)](#), [eq. \(2\)](#) for round bolting holes or by [\(2\)\(-b\)](#), [eq. \(4\)](#) for bolting holes slotted through the edge of the head.

(4) The required flange thickness shall be T as calculated in [\(2\)](#) or [\(3\)](#) above, but in no case less than the value of t calculated in [\(1\)](#).

(c) Heads of the Type Shown in [Figure HC-311](#), Sketch (c)

(1) Head thickness

$$t = \frac{SPL}{6S}$$

(2) Flange thickness

$$T = F + \sqrt{F^2 + J}$$

where

$$F = \frac{PB\sqrt{4L^2 - B^2}}{8S(A - B)}$$

and

$$J = \left(\frac{M_o}{SB} \right) \left(\frac{A + B}{A - B} \right)$$

HC-315 OPENINGS AND REINFORCEMENTS

(a) The dimensional requirements in [HG-320](#) through [HG-328](#) are applicable to cast iron and shall be used in the design of openings and reinforcements in boilers and boiler parts.

(b) Cast iron flanges, nozzles, and opening reinforcements that enter into the design calculations of the completed boiler or boiler part, shall be cast integrally with the boiler or boiler part.

HC-320 CORNERS AND FILLETS

(a) A liberal radius shall be provided at projecting edges, reentrant corners, and the juncture of nonload-bearing heat-transmitting fins and pins where they connect to the body of the casting, in accordance with good foundry practice. Abrupt changes in surface contour and in wall thickness at junctures shall be avoided.

(b) Fillets and transition sections between adjacent main pressure containment walls or integral attachments thereto, such as nozzles, lugs, supports, flanges, and bosses, shall have radii or the equivalent not less than one times the thickness of the thinner of the sections being joined.

HC-325 WASHOUT OPENINGS

All cast iron steam and hot water boilers shall be provided with washout openings to permit the removal of any sediment that may accumulate therein. Washout plugs shall not be smaller than NPS 1½ (DN 40) for boilers having gross internal volume more than 5 ft³ (142 L). Washout plugs shall not be smaller than NPS 1 (DN 25) for boilers having gross internal volume not more than 5 ft³ (142 L). Washout openings may be used for return pipe connections and the washout plug placed in a tee so that the plug is directly opposite and as close as possible to the opening in the boiler.

HC-330 ASSEMBLY METHOD

Cast iron boilers may be assembled using internal connections, such as electrochemically compatible metallic push nipples or grommet seals, or external

connections such as cast iron headers or threaded pipe headers. The completed boiler shall satisfactorily pass the hydrostatic test prescribed in [HC-410](#).

ARTICLE 4 TESTS

HC-400 TESTS TO ESTABLISH DESIGN PRESSURE

HC-401 General

(a) The design pressure for a boiler or boiler parts, for which the strength cannot be computed with a satisfactory assurance of accuracy, shall be established in accordance with the requirement of this paragraph using the following test procedure.

(b) Safety of testing personnel should be given serious consideration when conducting the bursting tests in [HC-402](#).

HC-401.1 Purpose for Which Tests May Be Used.

The tests in these paragraphs may be used for the purpose of establishing the design pressure of those parts or component parts for which the thickness cannot be determined by means of design rules given in this Section. Design changes shall also require a retest. The maximum allowable working pressure of all other elements or component parts shall not be greater than that determined by means of the applicable design rules.

HC-401.2 Frequency of Tests. The tests performed in [HC-401.1](#) shall be repeated within every 5-yr period. This testing period may be extended when parts are intermittently produced, in which case the tests shall be performed at the time of or before the first production run after the 5-yr period. All requirements of [HC-403](#) shall be met.

HC-402 Bursting Test Procedure

(a) The design pressure of any component part tested by this method shall be established by a hydrostatic test to failure by rupture of a full-size sample of such pressure part. As an alternative, the hydrostatic test may be stopped when the test pressure reaches a value that will, by the formula in (b), justify the design pressure.

(b) The design pressure of any component part determined by either method shall be based on hydrostatically testing three representative boilers or boiler parts. The lowest value of P_B obtained shall be used in determining the value of P_R in the following formula:²⁷

NOTE: See [HC-402.2](#) for "average tensile strength of associated test bar," which appears in the following equation.

$$P_R = \frac{P_B}{5} \times \left[\frac{\text{Specified minimum tensile strength}}{\text{Average tensile strength of associated test bar}} \right]$$

where

P_B = test pressure per (a), psi (kPa)

P_R = design pressure, psi (kPa)

NOTE: Due to the geometry of parts of cast iron boilers, failure under hydrostatic tests is principally in bending. When an analysis of the test indicates failure occurred in bending, P_R may be multiplied by 1.5.

HC-402.1 Test Gages.

(a) An indicating gage shall be connected directly to the vessel. If the indicating gage is not readily visible to the operator controlling the pressure applied, an additional indicating gage shall be provided where it will be visible to the operator throughout the duration of the test. For large vessels, it is recommended that a recording gage be used in addition to indicating gages.

(b) Dial indicating pressure gages used in testing shall be graduated over a range of about double the intended maximum test pressure, but in no case shall the range be less than $1\frac{1}{2}$ nor more than 4 times that pressure. Digital reading pressure gages having a wider range of pressure may be used provided the readings give the same or greater degree of accuracy as obtained with dial pressure gages.

(c) All gages shall be calibrated against a standard deadweight tester or a calibrated master gage. Gages shall be recalibrated at any time that there is reason to believe that they are in error.

HC-402.2 Associated Test Bars. A separately cast test bar shall be produced, machined, and tested in accordance with the requirements of the tension test procedure in [Article 2](#) of [Part HC](#) for each of the three boilers or boiler sections to be tested to destruction [see [HC-402\(b\)](#)]. Each test bar shall be from the same ladle of iron from which is cast the boiler or boiler section to be subjected to bursting. The arithmetical average tensile strength, psi, of the three bars shall be determined and shall equal or exceed the minimum tensile strength, specified in [Table HC-300](#), for the class of iron selected by the Manufacturer for use in the formula in [HC-402\(b\)](#) for determining the

design pressure. In no case shall the actual tensile strength of any of the three test bars, used to determine this arithmetical average tensile strength, be more than 10% under the minimum tensile strength listed in [Table HC-300](#) for the class of iron selected by the Manufacturer. The tensile strengths obtained from the associated test bars shall be recorded on the Manufacturer's Master Data Report for Boilers Constructed From Cast Iron ([Form H-5](#)).

(23) **HC-403 Witnessing, Recording, and Certifying Tests**

Tests to establish the design pressure of a boiler or boiler parts shall be witnessed by a Certified Individual (see [HC-502.12](#)). These bursting tests shall be recorded on the Manufacturer's Master Data Report Form, [Form H-5](#). The designated responsible engineering head of the Manufacturer shall certify the completed Manufacturer's Master Data Report Form by signature or some other method. These Manufacturer's Master Data Reports shall be kept on file by the Manufacturer as a matter of record.

Requirements for completing multiple pages of Manufacturer's Data Report Forms are shown in [Mandatory Appendix 4](#).

HC-404 Rating of Production Boilers Based on Tests

All boilers or boiler parts of the same material, design, and construction, whose design pressures are based on a test to destruction of a sample boiler or boiler part in accordance with [HC-402](#), shall be considered to have design pressures equal to the maximum allowable

working pressure thus determined and shall be subjected to a hydrostatic test pressure in conformity with rules of [HC-410](#).

HC-410 Hydrostatic Test

All completed boilers or boiler parts shall satisfactorily pass the hydrostatic test prescribed in this paragraph.

HC-410.1 Steam Boilers. All steam boilers shall have each individual section or boiler part subjected to a hydrostatic test pressure of not less than 60 psig (400 kPa) at the shop where made. The assembled boiler shall be subjected to a hydrostatic test of not less than 45 psig (300 kPa).

HC-410.2 Hot Water Boilers. All hot water heating or hot water supply boilers marked for maximum allowable working pressures not over 30 psi (200 kPa) shall have each individual section or boiler part subjected to a hydrostatic test of not less than 60 psi (400 kPa) at the shop where made. Hot water heating and hot water supply boilers marked for maximum allowable working pressures over 30 psi (200 kPa) shall have each individual section or boiler part subjected to a hydrostatic test of $2\frac{1}{2}$ times the maximum allowable working pressure at the shop where made. The assembled boiler shall be subjected to a hydrostatic test pressure not less than $1\frac{1}{2}$ times the maximum allowable working pressure.

HC-410.3 Required Test Pressure. In making hydrostatic pressure tests, the pressure shall be under such control that in no case shall the required test pressure be exceeded by more than 10 psi (70 kPa).

ARTICLE 5

QUALITY CONTROL AND INSPECTION

HC-501 GENERAL

HC-501.1 Quality Control System. Any Manufacturer²⁸ or Shop Assembler holding or applying for a Certificate of Authorization shall demonstrate a quality control program that meets the requirements of ASME CA-1 and establishes that all Code requirements, including material, design, testing, fabrication, examination, and inspection (by the Manufacturer and shop assembler), shall be met.

Providing that Code requirements are suitably identified, the system may include provisions for satisfying any requirements by the Manufacturer or shop assembler or user that exceed minimum Code requirements and may also include provision for quality control of non-Code work. In such systems, the Manufacturer or shop assembler may make changes in parts of the system that do not affect the Code requirements.

The system that the Manufacturer or shop assembler uses to meet the requirements of this Section must be one suitable for his own circumstances. The necessary scope and detail of the system shall depend upon the complexity of the work performed and upon the size and complexity of the organization. A written description of the system the Manufacturer or shop assembler will use to produce a Code item shall be available for review. Depending upon the circumstances, the description may be brief or voluminous.

The written description may contain information of a proprietary nature relating to the Manufacturer's or shop assembler's processes. Therefore, the Code does not require any distribution of this information, except to the ASME Designee, as covered by [HC-502.11.3](#). It is intended that information learned about the quality control system in connection with evaluation will be treated as confidential.

HC-502 OUTLINE OF FEATURES TO BE INCLUDED IN THE WRITTEN DESCRIPTION OF THE QUALITY CONTROL SYSTEM

The following is a guide to some of the features that should be covered in the written description of the quality control system.

HC-502.1 Product or Work Description. The quality control system shall contain a brief description of the products the Manufacturer wishes to fabricate under the Code or the work the shop assembler wishes to accomplish under the Code.

HC-502.2 Authority and Responsibility. The authority and responsibility of those in charge of the quality control system shall be clearly established. Persons performing quality control functions shall have sufficient and well-defined responsibility, the authority, and the organizational freedom to identify quality control problems and to initiate, recommend, and provide solutions.

HC-502.3 Organization. An organization chart showing the relationship between management and engineering, purchasing, manufacturing, inspection, and quality control is required to reflect the actual organization. The purpose of this chart is to identify and associate the various organizational groups with the particular function for which they are responsible. The Code does not intend to encroach on the Manufacturer's or shop assembler's right to establish and, from time to time, alter whatever form of organization the Manufacturer or shop assembler considers appropriate for his Code work.

HC-502.4 Drawings, Design Calculations, Test Results, and Specification Control. The Manufacturer's or shop assembler's quality control system shall provide procedures that will insure that the latest applicable drawings, design calculations, test results, specifications, and instructions required by the Code, as well as authorized changes, are used for manufacture, assembly, examination, inspection, and testing.

HC-502.5 Material Control. The Manufacturer or shop assembler shall include a system that requires verification that the material meets the requirements of [Part HC, Article 2](#). The system shall assure that only the intended material is used in Code construction.

HC-502.6 Examination Program. The Manufacturer's or shop assembler's quality control system shall describe the bursting test procedure and the fabrication operations, sufficiently to determine at which stages specific examinations are to be performed.

HC-502.7 Correction of Nonconformities. There shall be a system for correction of nonconformities. A nonconformity is any condition that does not comply with the applicable rules of this Section. Nonconformities must be corrected or eliminated before the completed component can be considered to comply with this Section.

HC-502.8 Calibration of Measurement and Test Equipment. The Manufacturer or shop assembler shall have a system for calibration of all equipment used for examination, measuring, and testing to fulfill the requirements of this Section.

HC-502.9 Sample Forms. The forms used in the quality control system and any detailed procedures for their use shall be available for review. The written description shall make necessary references to these forms. The forms exhibited shall be marked "Sample" and completed in a manner typical of actual production and test procedures.

HC-502.10 Retention of Records and Certifications.

(23) **HC-502.10.1 Retention of Records.** The Manufacturer or shop assembler shall have a system for retaining the Manufacturer's Master Data Reports for a minimum of 15 yr.

HC-502.10.2 Certifications. Methods other than written signature may be used for indicating certifications, authorizations, and approval where allowed and as described elsewhere in this Section. Where other methods are employed, controls and safeguards shall be provided and described to ensure the integrity of the certification, authorization, and approval.

HC-502.11 ASME Designee.

HC-502.11.1 The written description of the quality control system shall include reference to the ASME Designee.

HC-502.11.2 The Manufacturer or shop assembler shall make available to the ASME Designee a controlled copy of the written description of the quality control system.

HC-502.11.3 The Manufacturer's or shop assembler's quality control system shall provide for the ASME Designee to have access to all drawings, calculations, specifications, procedures, process sheets, repair procedures, records, test results, and any other documents as necessary for the ASME Designee to perform his review in accordance with this Section. The Manufacturer or shop assembler may provide such

access either to his own files of such documents or by providing copies to the ASME Designee.

HC-502.12 Certified Individual (CI). A Certified Individual shall provide oversight of the activities that affect the proper utilization and application of the Certification Mark with H designator on cast iron sections as outlined in [Part HC](#).

HC-502.12.1 Requirements for a Certified Individual (CI). A Certified Individual (CI) shall

- (a) be qualified in accordance with ASME CA-1
- (b) have the following qualifications as a minimum:
 - (1) knowledge of the requirements of [Parts HG](#) and [HC](#)
 - (2) knowledge of the Manufacturer or shop assembler's quality program
 - (3) training commensurate with the scope, complexity, or special nature of the activities to which oversight is to be provided
- (c) have a record, maintained and certified by the Manufacturer or shop assembler, containing objective evidence of the qualifications and training of the CI meeting the current requirements of ASME QAI-1
- (d) not be directly involved in the production of cast iron sections for which he is performing the duties listed in [HC-502.12.2](#)

HC-502.12.2 Duties of a Certified Individual (CI). A Certified Individual (CI) shall

- (a) witness tests to determine the design pressure of a boiler or boiler part as outlined in [HC-403](#).
- (b) verify that cast iron sections marked with the Certification Mark with H designator have a current Manufacturer's Master Data Report. [Form H-5](#) shall be used.
- (c) review the tensile and chemical composition tests records, verifying that they meet the requirements of [Part HC, Article 2](#).
- (d) review documentation to verify that cast iron sections marked with the Certification Mark with H designator have been hydrostatically tested as required by [HC-410](#).
- (e) verify that the application of the nameplates, with the Certification Mark with H designator, meets the requirements of [HG-530.2](#).
- (f) sign the Certificates of Conformance as outlined in [HC-520](#).

HC-510 EXAMINATION

Examination of each boiler or boiler part shall be in compliance with [Part HC, Article 2](#). Hydrostatic tests shall be conducted as required in [HC-410](#) by the Manufacturer or shop assembler, and there shall be a means of identifying acceptable boiler sections or parts.

HC-520 CERTIFICATES OF CONFORMANCE

Cast iron boiler sections marked with the Certification Mark with H designator shall be recorded on Certificates of Conformance as follows:

(a) A Certificate of Conformance [Form HC-1](#) listing the pattern number, cast date, and quantity of castings marked with the Certification Mark with H designator shall be filled out and certified by a representative of the Manufacturer and certified by a Certified Individual. Certification by the representative of the Manufacturer and the Certified Individual may be by signature or some other method of control in accordance with the Manufacturer's Quality Control System.

(1) Multiple cast iron boiler sections may be recorded on the same [HC-1](#) form.

(2) Castings with the same cast date may be recorded on the same line.

(b) A Certificate of Conformance [Form HC-2](#) listing the pattern number, MAWP, hydrostatic test pressure, and quantity of cast iron sections that have satisfactorily passed the hydrostatic test required in [HC-410](#) shall be filled out and certified by a representative of the Manufacturer and certified by a Certified Individual. Certification by the representative of the Manufacturer

and the Certified Individual may be by signature or some other method of control in accordance with the Manufacturer's Quality Control System.

Multiple cast iron boiler sections may be recorded on the same [HC-2](#) form.

(c) A Certificate of Conformance [Form HC-3](#) listing the nameplate, with the Certification Mark with H designator, part number, quantity applied, boiler model number, and date applied shall be filled out and signed by a representative of the Manufacturer or shop assembler, and signed by a Certified Individual.

Multiple nameplates may be recorded on the same [HC-3](#) form.

(d) The Manufacturer or shop assembler's written quality control program shall include requirements for completion of the Certificates of Conformance and retention by the Manufacturer or shop assembler for a minimum of 5 yr.

(e) The representative of the Manufacturer or shop assembler and the Certified Individual above shall not be the same person.

(f) Requirements for completing Certificate of Conformance Forms are shown in [Mandatory Appendix 4](#).

PART HA

REQUIREMENTS FOR BOILERS CONSTRUCTED

OF CAST ALUMINUM

ARTICLE 1

GENERAL

HA-100 SCOPE

The rules in [Part HA](#) are applicable to hot water heating boilers that are constructed primarily of cast aluminum sections and shall be used in conjunction with general requirements of [Part HG](#) of this section.

ARTICLE 2

MATERIAL REQUIREMENTS

HA-200 GENERAL MATERIAL REQUIREMENTS

(a) All materials used for cast sections of heating boilers that are constructed primarily of cast aluminum shall meet the requirements of this Article and material specifications listed in [HF-300.2](#) for aluminum castings.

(b) External appurtenances such as cast or welded headers and other miscellaneous pressure parts shall be manufactured from materials permitted under Part [HF-203](#). The design pressure for these pressure parts for which the strength cannot be computed shall be established in accordance with [HG-500](#).

(c) Maximum allowable water temperature is 250°F (120°C).

HA-201 WORKMANSHIP, FINISH, AND REPAIR

(a) The surface of the casting shall conform substantially to the dimensions on drawings or to the dimensions predicated by the pattern, and be free from injurious defects. The surface of the casting shall be free from burnt-on sand and shall be reasonably smooth. Risers, fins, and projections used to facilitate the making of the casting shall be removed. In other respects, they shall conform to whatever requirements may be specially agreed upon between the Manufacturer and shop assembler when the shop assembler is separate from the Manufacturer.

(b) Seepage about chaplets, and minor leakage defects, may be repaired by plugging, impregnation, or welding as directed in the following:

(1) Provided the surrounding metal is sound, a minor leak may be plugged with a solid aluminum, brass, or stainless steel tapered thread pipe plug. The maximum size of the pipe plug shall be NPS 1 (DN 25) and there shall be no less than four full standard pipe threads in the section metal (see [Table HC-214](#)).

(2) Impregnation may be used to correct seepage leaks in aluminum alloy castings under the following conditions:

(-a) Limitations of the extent and frequency of impregnation shall be as approved in the Manufacturer's written quality control system.

(-b) Impregnated castings shall be marked in a way that is approved in the Manufacturer's written quality control system. The method of marking shall be

documented in the shop assembler's QC manual when the shop assembler is separate from the Manufacturer.

(-c) Control of the impregnation process shall be addressed in the Manufacturer's QC manual.

(-d) The impregnation material shall meet the requirements of Class 1 material as defined in MIL-I-17563C.²⁹

(-e) Impregnation shall be accomplished in accordance with MIL-STD-276.²⁹

(-f) Welding shall not be performed on castings after impregnation.

(-g) The Manufacturer shall hydrostatically test each casting per [HA-406](#) after impregnation.

(3) Castings may be repaired by welding only as approved in the Manufacturer's and shop assemblers written quality control system.

(-a) Limitations on the extent and frequency of such repairs, and methods of inspection of repaired areas shall also be covered in the written quality control system.

(-b) The welding procedure and welders shall be qualified in accordance with Section IX.

(-c) Control of the welding process shall be addressed in the quality control manual.

(-d) Welding shall not be performed after impregnation.

HA-202 EXAMINATIONS AND TESTS

The Manufacturer shall be responsible for all examinations and tests. When requested by a shop assembler, the Manufacturer shall agree to permit a representative of the shop assembler to have entry, at the time while work under the contract of the shop assembler is being performed, to all parts of the Manufacturer's works that concern the castings manufactured to the requirements of this Article. All examinations and tests shall be made at the place of manufacture prior to shipment, unless otherwise specified and shall be so conducted as not to interfere unnecessarily with the operation of the works.

HA-203 TEST RECORDS

The Manufacturer shall record and retain all test results required by this Article for a period of at least 1 yr. The test results shall be readily identifiable with the casting represented by the test results.

ARTICLE 3 DESIGN

HA-300 MAXIMUM ALLOWABLE STRESS VALUES

(a) Section II, Part D, Table 6B gives the maximum allowable stress values in tension for aluminum castings.

(b) Stress values in Section II, Part D, Table 6B shall be used in calculations employing the available formulas in Part HG when applicable to the geometry of the boiler or boiler parts. Where the design pressure cannot be calculated under the available formulas, then the design pressure of the part in question shall be established in accordance with the provisions of HA-400.

HA-301 HEADS AND SPHERICALLY SHAPED COVERS

Circular spherically dished heads with bolting flanges, concave to the pressure and conforming to the several types illustrated in Figure HC-311 shall be designed in accordance with HC-311 and HC-311.1.

HA-302 OPENINGS AND REINFORCEMENTS

(a) The dimensional requirements in HG-320 through HG-328 are applicable to aluminum and shall be used in the design of openings and reinforcements in boilers and boiler parts.

(b) Cast flanges, nozzles, and opening reinforcements that enter into design calculations of the completed boiler or boiler part shall be cast integrally with the boiler or boiler part.

(c) Core holes in aluminum alloy castings may be plugged with electrochemically compatible push-in sealing caps under the following conditions:

(1) The sealing caps shall only be used to plug holes required for the manufacturing process, such as core sand removal. They shall not be used for repair.

(2) The dimensions of the plug and mating hole shall conform to manufacturers' standards or such published standards as DIN 443.

(3) Proof testing to establish design pressure is required and shall comply with HA-402.

(4) The shop assembler shall hydrostatically test each casting per HA-406.

(d) Core holes in aluminum alloy castings may be plugged by welded patches made of the same material as the castings under the following conditions:

(1) The welded plugs may only be used to plug holes required for the manufacturing process, such as core sand removal. They shall not be used for repair.

(2) Proof testing to establish design pressure is required and shall comply with HA-402.

(3) The shop assembler shall hydrostatically test each casting per HA-406.

HA-303 CORNERS AND FILLETS

(a) A liberal radius shall be provided at projecting edges and reentrant corners, and the juncture of non-load-bearing heat transmitting fins and pins where they connect to the body of the casting, in accordance with good foundry practice. Abrupt changes in surface contour and in wall thickness at junctures shall be avoided.

(b) Fillets and transition sections between adjacent main pressure containment walls or integral attachments thereto, such as nozzles, lugs, supports, flanges, and bosses, shall have radii or the equivalent not less than one-half times the thickness of the thinner of the sections being joined.

HA-304 WASHOUT OPENINGS

All cast aluminum hot water boilers shall be provided with washout openings to permit the removal of any sediment that may accumulate therein. Washout plugs shall not be smaller than NPS 1½ (DN 40) for boilers having a gross internal volume more than 5 ft³ (142 L). Washout plugs shall not be smaller than NPS 1 (DN 25) for boilers having gross internal volumes from 2.0 ft³ (57 L) through 5.0 ft³ (142 L). Washout plugs shall not be smaller than NPS ¾ (DN 20) for boilers having gross internal volumes less than 2.0 ft³ (57 L). Washout openings may be used for return pipe connections and the washout plug placed in a tee so that the plug is directly opposite and as close as possible to the opening in the boiler.

HA-305 ASSEMBLY METHOD

Cast aluminum boilers may be assembled using internal connections, such as electrochemically compatible metallic push nipples, grommet seals, or external connections such as cast headers or threaded pipe headers. The complete boiler shall satisfactorily pass the hydrostatic test prescribed in HA-406.

ARTICLE 4 TESTS

HA-400 TESTS TO ESTABLISH DESIGN PRESSURE

HA-401 General

(a) The design pressure for a boiler or boiler parts for which the strength cannot be computed shall be established in accordance with the requirements of this paragraph using the following test procedure.

(b) Safety of testing personnel should be given serious consideration when conducting the bursting tests in HA-402.

HA-401.1 Purpose for Which Tests May Be Used.

The tests in these paragraphs may be used for the purpose of establishing the design pressure of those parts or component parts for which the thickness cannot be determined by means of design rules given in this Section. Design changes shall also require a retest. The maximum allowable working pressure of all other elements or component parts shall not be greater than that determined by means of the applicable design rules.

HA-401.2 Frequency of Tests. The tests performed in HA-401.1 shall be repeated within every 5-year period. This testing period may be extended when parts are intermittently produced, in which case the tests shall be performed at the time of or before the first production run after the 5-year period. All requirements of HA-403 shall be met.

HA-402 Bursting Test Procedure

(a) The design pressure of any component part tested by this method shall be established by a hydrostatic test to failure by rupture of a full-size sample of such pressure part. As an alternative, the hydrostatic test may be stopped when the test pressure reaches a value that will, by the formula in (b), justify the design pressure.

(b) The design pressure of any component part determined by this method shall be based on hydrostatically testing three representative boilers or boiler parts. The lowest value of P_B obtained shall be used in determining the value of P_R in the following formula:

$$P_R = \frac{P_B}{5} \times \frac{S}{S_a \text{ or } S_m} \times \frac{S_2}{S_1}$$

where

P_B = test pressure per (a), psi (kPa)

P_R = design pressure, psi (kPa)

S = specified minimum tensile strength, psi (kPa)

S_1 = maximum allowable stress at room temperature, psi (kPa)

S_2 = maximum allowable strength at design temperature, psi (kPa)

S_a = average actual tensile strength of test specimens, psi (kPa)

S_m = maximum tensile strength of range of specimens, psi (kPa)

HA-403 Test Gages

(a) An indicating gage shall be connected directly to the vessel. Intermediate pipe and fittings may be used provided there are no intervening valves. If the indicating gage is not readily visible to the operator controlling the pressure applied, an additional indicating gage shall be provided where it will be visible to the operator throughout the duration of the test. For large vessels, it is recommended that a recording gage be used in addition to indicating gages.

(b) Dial indicating pressure gages used in testing shall be graduated over a range of about double the intended maximum test pressure, but in no case shall the range be less than $1\frac{1}{2}$ or more than 4 times that pressure. Digital reading pressure gages having a wider range of pressure may be used provided the readings give the same or greater degree of accuracy as obtained with dial pressure gages.

(c) All gages shall be calibrated against a standard deadweight tester or a calibrated master gage. Gages shall be recalibrated at any time that there is reason to believe that they are in error.

(23) HA-404 Witnessing, Recording, and Certifying Tests

Test to establish the design pressure of a boiler or boiler parts shall be witnessed by a Certified Individual. See [HA-502.12](#). These bursting tests shall be recorded on the Manufacturer's Master Data Report Form, [Form H-5A](#). The designated responsible engineering head of the Manufacturer shall certify the completed Manufacturer's Master Data Report Form by signature or some other method. These Manufacturer's Master Data Reports shall be kept on file by the Manufacturer as a matter of record.

Requirements for completing multiple pages of Manufacturer's Data Report Forms are shown in [Mandatory Appendix 4](#).

HA-405 Rating of Production Boilers Based on Tests

All boilers or boiler parts of the same material, design, and construction, whose design pressures are based on a test to destruction of a sample boiler or boiler part in accordance with [HA-402](#), shall be considered to have design pressures equal to the maximum allowable working pressure thus determined and shall be subjected to a hydrostatic test pressure in conformity with rules of [HA-406](#).

HA-406 Hydrostatic Test

All completed boilers or boiler parts shall satisfactorily pass the hydrostatic test prescribed in this paragraph.

HA-406.1 Hot Water Boilers.

(a) Hot water heating boilers marked for maximum allowable working pressures not over 30 psi (200 kPa) shall have each individual section or boiler part subjected to a hydrostatic test of not less than 60 psi (400 kPa) at the shop where made.

(b) Hot water heating boilers marked for maximum allowable working pressures over 30 psi (200 kPa) shall have each individual section or boiler part subjected to a hydrostatic test of $2\frac{1}{2}$ times the maximum allowable working pressure at the shop where made.

(c) The assembled boiler shall be subjected to a hydrostatic test pressure not less than $1\frac{1}{2}$ times the maximum allowable working pressure.

(1) Cast aluminum monoblock boilers, boilers with a single section design that do not require additional machining or assembly, do not require a second hydrostatic test at $1\frac{1}{2}$ times the maximum allowable working pressure.

(-a) Any additional machining, shot blasting, or grinding after the hydrostatic test will require testing at $1\frac{1}{2}$ times the maximum allowable working pressure.

HA-406.2 Required Test Pressure. In making hydrostatic pressure tests, the pressure shall be under such control that in no case shall the required test pressure be exceeded by more than 10 psi (70 kPa).

HA-407 Pneumatic Tests

As an alternative to the hydrostatic test required in [HA-406.1\(c\)](#), cast aluminum boilers may be pneumatically tested, provided the following requirements are met:

(a) The use of pneumatic testing in lieu of hydrostatic testing shall be documented in the quality control system.

(b) Maximum material thickness of any component part shall not exceed $\frac{1}{2}$ in. (12.7 mm).

(c) When the boiler is under pneumatic pressure testing, its calculated potential energy, E , shall be less than 1,000 ft-lb (1 356 J).

$$E = C \times P_{at} \times V [1 - (P_a/P_{at})]^{0.286}$$

where

C = constant, 360 in.²/ft² (2 500 Pa/kPa)

E = stored energy, ft-lb (J)

P_a = absolute atmospheric pressure, 14.7 psia (101 kPa)

P_{at} = absolute test pressure, psia (kPa)

V = total volume under test pressure, ft³ (m³)

NOTE: V includes the volume of the vessel and any connected volume to the pressure supply pump or valve.

(d) Nitrogen or clean, dry, oil-free air shall be used.

(e) The boiler shall be visually inspected for evidence of damage before pressurization.

(f) The boiler should be tested in such a manner as to ensure personnel safety from a release of the total internal energy of the vessel.

(g) The required test pressure shall be the greater of 38 psi (262 kPa) or 1.1 times the MAWP.

(h) Overpressure relief protection shall be provided. The set pressure of a pressure relief valve shall not exceed the greater of the following:

(1) the test pressure plus 10 psi (70 kPa)

(2) 110% of the test pressure

(i) A minimum hold time of 5 min shall be maintained on the boiler at the required test pressure.

(j) The pneumatic test method shall be immersed visual inspection.

(1) The boiler shall be externally cleaned to prevent air bubble adherence while being tested to prevent leaks from being masked.

(2) The uppermost portion of the boiler, as oriented in the test tank, shall be a minimum of 6 in. (150 mm) below the surface of the water, and the water shall have a minimum temperature of 60°F (16°C).

(3) Before the holding period, the immersed boiler shall be rotated a minimum of 180 deg around a lateral axis to release any trapped air.

(4) After the holding period, the pressure may be reduced to the MAWP, but not less than 38 psi (262 kPa), and maintained at this pressure while a thorough visual inspection for leakage is made with the boiler submerged in water.

(5) After the holding period, and during the visual inspection, the immersed boiler shall be rotated a minimum of 180 deg around a lateral axis to permit easy visual detection of any leakage.

(6) Any evidence of air leaking from the vessel will indicate failure of the pneumatic pressure test.

ARTICLE 5

QUALITY CONTROL AND INSPECTION

HA-501 GENERAL

HA-501.1 Quality Control System. Any Manufacturer²⁸ or Shop Assembler holding or applying for a Certificate of Authorization shall demonstrate a quality control program that meets the requirements of ASME CA-1 and establishes that all Code requirements, including material, design, testing, fabrication, examination, and inspection (by the Manufacturer and shop assembler) shall be met.

Providing that Code requirements are suitably identified, the system may include provisions for satisfying any requirements by the Manufacturer or shop assembler or user that exceed minimum Code requirements and may also include provision for quality control of non-Code work. In such systems, the Manufacturer or shop assembler may make changes in parts of the system, which do not affect the Code requirements.

The system that the Manufacturer or shop assembler uses to meet the requirements of this Section must be one suitable for his own circumstances. The necessary scope and detail of the system shall depend upon the complexity of the work performed and the size and complexity of the organization. A written description of the system the Manufacturer or shop assembler will use to produce a Code item shall be available for review. Depending upon the circumstances, the description may be brief or voluminous.

The written description may contain information of a proprietary nature relating to the Manufacturer's or shop assembler's processes. Therefore, the Code does not require any distribution of this information, except to the ASME Designee, as covered by [HA-502.11.3](#). It is intended that information learned about the quality control system in connection with evaluation will be treated as confidential.

HA-502 OUTLINE OF FEATURES TO BE INCLUDED IN THE WRITTEN DESCRIPTION OF THE QUALITY CONTROL SYSTEM

The following is a guide to some of the features that should be covered in the written description of the quality control system.

HA-502.1 Product or Work Description. The quality control system shall contain a brief description of the products the Manufacturer wishes to fabricate under the Code or the work the shop assembler wishes to accomplish under the Code.

HA-502.2 Authority and Responsibility. The authority and responsibility of those in charge of the quality control shall be clearly established. Persons performing quality control functions shall have sufficient and well-defined responsibility, the authority, and the organizational freedom to identify quality control problems and to initiate, recommend, and provide solutions.

HA-502.3 Organization. An organization chart showing the relationship between management and engineering, purchasing, manufacturing, inspection and quality control is required to reflect the actual organization. The purpose of this chart is to identify and associate the various organizational groups with the particular function for which they are responsible. The Code does not intend to encroach on the Manufacturer's or shop assembler's right to establish and, from time to time, alter whatever form of organization the Manufacturer or shop assembler considers appropriate for his Code work.

HA-502.4 Drawings, Design Calculations, Test Results, and Specification Control. The Manufacturer's or shop assembler's quality control system shall provide procedures that will insure that the latest applicable drawings, design calculations, test results, specifications, and instructions required by the Code, as well as authorized changes, are used for manufacture, assembly, examination, inspection, and testing.

HA-502.5 Material Control. The Manufacturer or shop assembler shall include a system that requires verification that the material meets the requirements of [Part HA, Article 2](#). The system shall assure that only the intended material is used in Code construction.

HA-502.6 Examination Program. The Manufacturer's or shop assembler's quality control system shall describe the bursting test procedure and the fabrication operations, sufficiently to determine at which stages specific examinations are to be performed.

HA-502.7 Correction of Nonconformities. There shall be a system for correction of nonconformities. A nonconformity is any condition that does not comply with the applicable rules of this Section. Nonconformities must be corrected or eliminated before the completed component can be considered to comply with this Section.

HA-502.8 Calibration of Measurement and Test Equipment. The Manufacturer or shop assembler shall have a system for calibration of all equipment used for examination, measuring, and testing to fulfill the requirements of this Section.

HA-502.9 Sample Forms. The forms used in the quality control system and any detailed procedures for their use shall be available for review. The written description shall make necessary references to these forms. The forms exhibited shall be marked "Sample" and completed in a manner typical of actual production and test procedures.

HA-502.10 Retention of Records and Certifications.

(23) **HA-502.10.1 Retention of Records.** The Manufacturer or shop assembler shall have a system for retaining the Manufacturer's Master Data Reports for a minimum of 15 yr.

HA-502.10.2 Certifications. Methods other than written signature may be used for indicating certifications, authorizations, and approval where allowed and as described elsewhere in this Section. Where other methods are employed, controls and safeguards shall be provided and described to ensure the integrity of the certification, authorization, and approval.

HA-502.11 ASME Designee.

HA-502.11.1 The written description of the quality control system shall include reference to the ASME Designee.

HA-502.11.2 The Manufacturer or shop assembler shall make available to the ASME Designee a controlled copy of the written description of the quality control system.

HA-502.11.3 The Manufacturer's or shop assembler's quality control system shall provide for the ASME Designee to have access to all drawings, calculations, specifications, procedures, process sheets, repair procedures, records, test results, and any other documents as necessary for the ASME Designee to perform his review in accordance with this Section. The Manufacturer or shop assembler may provide such access either to his own files

of such documents or by providing copies to the ASME designee.

HA-502.12 Certified Individual (CI). A Certified Individual shall provide oversight of the activities that affect the proper utilization and application of the Certification Mark with H designator on cast aluminum sections as outlined in [Part HA](#).

HA-502.12.1 Requirements for a Certified Individual (CI).

A Certified Individual shall

- (a) be qualified in accordance with ASME CA-1
- (b) have the following qualifications as a minimum:
 - (1) knowledge of the requirements of [Parts HG, HC, and HA](#)
 - (2) knowledge of the Manufacturer or shop assembler's quality control system
 - (3) training commensurate with the scope, complexity, or special nature of the activities to which oversight is provided
- (c) have a record, maintained and certified by the Manufacturer or shop assembler, containing objective evidence of the qualifications and training of the CI meeting the current requirements of ASME QAI-1
- (d) not be directly involved in the production of cast aluminum sections for which he is performing the duties listed in [HA-502.12.2](#)

HA-502.12.2 Duties of a Certified Individual (CI).

(23) A Certified Individual (CI) shall

- (a) witness tests to determine the design pressure of boiler or boiler part as outlined in [HA-404](#).
- (b) verify that cast aluminum sections marked with the Certification Mark with H designator shall have a current Manufacturer's Master Data Report. [Form H-5A](#) shall be used.
- (c) review the tensile and chemical composition tests records, verifying that they meet the requirements of Section II, Part D, Table 6B.
- (d) review documentation to verify that cast aluminum sections marked with the Certification Mark with H designator have been hydrostatically tested as required by [HA-406](#).
- (e) verify that the application of the nameplates, with the Certification Mark with H designator, meets the requirements of [HG-530.2](#).
- (f) sign the Certificates of Conformance as outlined in [HA-504](#).

HA-503 EXAMINATION

Examination of each boiler or part shall be in compliance with [Article 2](#) of [Part HA](#). Hydrostatic tests shall be conducted as required in [HA-406](#) by the Manufacturer or shop assembler, and there shall be a means of identifying acceptable boiler sections or parts.

HA-504 CERTIFICATES OF CONFORMANCE

Cast aluminum boiler sections marked with the Certification Mark with H designator shall be recorded on Certificates of Conformance as follows:

(a) A Certificate of Conformance [Form HA-1](#) listing the pattern number, cast date, and quantity of castings marked with the Certification Mark with H designator shall be filled out and certified by a representative of the Manufacturer and certified by a Certified Individual. Certification by the representative of the Manufacturer and the Certified Individual may be by signature or some other method of control in accordance with the Manufacturer's Quality Control System.

(1) Multiple cast aluminum boiler sections may be recorded on the same [HA-1](#) form.

(2) Castings with the same casting date may be recorded on the same line.

(b) A Certificate of Conformance [Form HA-2](#) listing the pattern number, MAWP, hydrostatic test pressure, and quantity of cast aluminum sections that have satisfactorily passed the hydrostatic test required in [HA-406](#) shall be filled out and certified by a representative of the Manufacturer and certified by a Certified Individual. Certification by the representative of the Manufacturer

and the Certified Individual may be by signature or some other method of control in accordance with the Manufacturer's Quality Control System.

Multiple cast aluminum boiler sections may be recorded on the same [HA-2](#) form.

(c) A Certificate of Conformance [Form HA-3](#) listing the nameplate, with the Certification Mark with H designator, part number, quantity applied, boiler model number, and date applied shall be filled out and signed by a representative of the Manufacturer or shop assembler, and signed by a Certified Individual.

Multiple nameplates may be recorded on the same [HA-3](#) form.

(d) The Manufacturer's or shop assembler's written quality control program shall include requirements for completion of the Certificates of Conformance and retention by the Manufacturer or shop assembler for a minimum of 5 yr.

(e) The representative of the Manufacturer or shop assembler and the Certified Individual above shall not be the same person.

(f) Requirements for completing Certificate of Compliance Forms are shown in [Mandatory Appendix 4](#).

PART HLW

REQUIREMENTS FOR POTABLE-WATER HEATERS

INTRODUCTION

The following is a brief introduction to [Part HLW](#). It is general in nature, and should not be considered as a substitute for actual review of appropriate articles of the document. However, this will give the user a better understanding of the purpose, requirements, and intent of [Part HLW](#).

[Part HLW](#) applies to water heaters and storage tanks in commercial or industrial sizes providing corrosion resistance for supplying potable hot water for commercial purposes at pressures not exceeding 160 psig (1 100 kPa) and temperatures not exceeding 210°F (99°C).

[Part HLW](#) does not apply to residential size water heaters, which are excluded by provisions of [HLW-101](#).

Differences in applicable criteria for water heaters versus hot water heating and hot water supply boilers are as follows:

(a) In a water heater, the temperature of the water is limited to a maximum of 210°F (99°C).

(b) A water heater is provided with a corrosion resistant lining or constructed with corrosion resistant materials.

(c) A water heater is intended to supply potable hot water with all makeup from a potable water supply system. Vessels built under the rules of [Part HLW](#) may be used for storage of potable water.

The following is a brief outline of the contents of each Article of [Part HLW](#).

ARTICLE 1 — GENERAL

The scope of [Part HLW](#) is given, and the service restriction and exemption are stated.

ARTICLE 2 — MATERIALS

The material requirements for the linings permitted are specified as well as the lining thickness requirements. The material requirements specified for the lining materials were, in general, taken from existing standards by

abstracting those requirements that were considered to be those essential for the applications covered by these rules.

ARTICLE 3 — DESIGN

The design criteria for water heaters is given in this Article. The pressure is specified as a maximum allowable working pressure of 160 psi (1 100 kPa) with a minimum of 100 psi (700 kPa). The maximum water temperature permitted is 210°F (99°C).

The maximum allowable working pressure of the water heater shall be established in accordance with the proof test provision of [HLW-500](#). As an alternative, stress values in Section II, Part D, Table 6C may be used in calculations employing the available formulas when applicable to the geometry of the lined water heater or parts.

ARTICLE 4 — WELDMENTS

The provisions for weldment joint design are similar to those given elsewhere in this Section and in Section VIII, Division 1. In addition, some acceptable joint designs are provided that have been commonly used in the construction of water heaters and have provided satisfactory service performance.

ARTICLE 5 — TESTS

Proof test procedure is delineated for establishing the maximum allowable working pressure of a water heater or parts, and this test is required to be witnessed and accepted by the Authorized Inspector. The Manufacturer's Master Data Proof Test Report for Lined Water Heaters shall be certified by the designated responsible engineering head of the Manufacturer and the forms shall be kept on file by the Manufacturer as a matter of record.

ARTICLE 6 — INSPECTION AND MARKING

Inspection and marking requirements for water heaters are given. The Certification Mark with HLW designator is provided for water heaters made in accordance with [Part HLW](#).

ARTICLE 7 — CONTROLS

Each water heater is required to have an operating control and a separate high-limit temperature-actuated control that shuts off the fuel supply in case of operating control failure. Water heaters should be equipped with

suitable primary safety controls, safety limit switches, burners, or electric elements as appropriate and as required by a nationally recognized standard. Examples of these nationally recognized standards are listed.

ARTICLE 8 — INSTALLATION

Some acceptable piping installations are shown. Provisions for the installation of pressure relief valves and other valves are given.

ARTICLE 1

GENERAL

HLW-100 SCOPE

(a) The rules in [Part HLW](#) apply to water heaters and water storage tanks with corrosion resistance for supplying potable hot water. The Foreword provides the basis for these rules. [Part HLW](#) is not intended to apply to hot water heating boilers, hot water supply boilers, or water storage tanks without corrosion resistance.

(b) This Part contains mandatory requirements, specific prohibitions, and nonmandatory guidance for materials, designs, fabrication, examination, inspection, testing, certification, and overpressure protection.

(c) Laws or regulations issued by a municipality, state, provincial, federal, or other enforcement or regulatory body having jurisdiction at the location of an installation, establish the mandatory applicability of these rules, in whole or in part.

HLW-101 SERVICE LIMITS

(a) The rules of Part HLW apply to

(1) potable water heaters that exceed an input greater than 200,000 Btu/hr (60 kW) or a nominal water-containing capacity of 120 gal (450 L)

(2) potable water storage tanks with a nominal water-containing capacity of 120 gal (450 L) or greater

(b) The rules of Part HLW apply to potable water heaters and water storage tanks designed for pressures not exceeding 160 psi (1 100 kPa) or water temperatures not exceeding 210°F (99°C).

HLW-102 PERMISSIBLE MARKING

Any water heater or storage tank that meets all of the requirements of [Part HLW](#), including those for inspection, may be marked with the Code HLW Symbol even though exempted from such marking.

HLW-103 UNITS

Either U.S. Customary, SI, or any local customary units may be used to demonstrate compliance with all requirements of this edition (e.g., materials, design, fabrication, examination, inspection, testing, certification, and overpressure protection).

In general, it is expected that a single system of units shall be used for all aspects of design except where unfeasible or impractical. When components are manufactured at different locations where local customary units are different than those used for the general design, the local units may be used for the design and documentation of that component. Similarly, for proprietary components or those uniquely associated with a system of units different than that used for the general design, the alternate units may be used for the design and documentation of that component.

For any single equation, all variables shall be expressed in a single system of units. When separate equations are provided for U.S. Customary and SI units, those equations must be executed using variables in the units associated with the specific equation. Data expressed in other units shall be converted to U.S. Customary or SI units for use in these equations. The result obtained from execution of these equations may be converted to other units.

Production, measurement and test equipment, drawings, welding procedure specifications, welding procedure and performance qualifications, and other fabrication documents may be in U.S. Customary, SI, or local customary units in accordance with the fabricator's practice. When values shown in calculations and analysis, fabrication documents, or measurement and test equipment are in different units, any conversions necessary for verification of Code compliance and to ensure that dimensional consistency is maintained shall be in accordance with the following:

(a) Conversion factors shall be accurate to at least four significant figures.

(b) The results of conversions of units shall be expressed to a minimum of three significant figures.

Conversion of units, using the precision specified above shall be performed to assure that dimensional consistency is maintained. Conversion factors between U.S. Customary and SI units may be found in the [Nonmandatory Appendix M](#), Guidance for the Use of U.S. Customary and SI Units in the ASME Boiler and Pressure Vessel Code. Whenever local customary units are used the Manufacturer shall provide the source of the conversion factors, which shall be subject to verification and acceptance by the Authorized Inspector or Certified Individual.

Material that has been manufactured and certified to either the U.S. Customary or SI material specification (e.g., SA-516M) may be used regardless of the unit system used in design. Standard fittings (e.g., flanges, elbows, etc.) that have been certified to either U.S. Customary units or SI units may be used regardless of the unit system used in design.

All entries on a Manufacturer's Data Report and data for Code required nameplate marking shall be in units consistent with the fabrication drawings for the component using U.S. Customary, SI, or local customary units. It is acceptable to show alternate units parenthetically. Users of this Code are cautioned that the receiving Jurisdiction should be contacted to ensure the units are acceptable.

ARTICLE 2

MATERIAL REQUIREMENTS

(23) HLW-200 LINING

(a) *Glass Linings.* Glass lining shall be of an analysis intended for use in hot water service and the minimum average thickness shall be 0.005 in. (0.13 mm). The walls, ends, and other parts that are of steel and are glass lined shall be of a quality that is suitable for glass lining by the manufacturer's glass lining process. Glass lining may be applied to parts before assembly. The surfaces of the water heater vessel that are exposed to hot water shall have a coating with a minimum number of discontinuities, and the discontinuities shall average not more than $\frac{1}{8}$ in.²/ft² (8 cm²/m²) of internal surface excluding edges and fittings. Thinning at corners may not extend over $\frac{1}{4}$ in. (6 mm) from the edge.

(b) *Galvanized Coatings.* The galvanized coating shall be based upon at least 1 oz of zinc/ft² (3 gal/m²) of surface based upon mathematical calculations corresponding to a coating thickness of 0.0017 in. (0.043 mm). The weight of the zinc coating shall be determined by weighing the water heater before galvanizing and again after the coating is applied.

The zinc used for coating shall conform to ASTM B6, Specification for Zinc (Slab Zinc) and shall be at least equal to the grade designated as "Prime Western." The aluminum content of the bath during actual galvanizing operations shall not exceed 0.01%. The galvanizer shall not damage the material by overpickling or by the use of excessively high temperature in pickling or galvanizing.

(c) *Cement Linings.* For cement-lined water heaters, the cement shall be applied to provide a minimum thickness of $\frac{3}{16}$ in. (5 mm). The lining shall be properly cured, adhere firmly to, and completely cover the interior of the vessel. The joints at the top of the water heater shall be sealed to prevent corrosion in back of the lining. The water absorption of the lining material shall not be more than 17% of the dry weight of the test specimen. The calcium oxide content shall not exceed 35%. The silicon content shall not be less than 25%.

(d) *Copper Linings.* The material used for lining may be any copper of weldable or brazeable quality with a minimum thickness of 0.005 in. (0.13 mm). Lining attachments to steel backing by welding or brazing shall be in accordance with Section IX.

(e) *Fluorocarbon Polymer Linings.* Fluorocarbon polymer linings shall be of an analysis intended for use in potable hot water service, and the minimum thickness shall be 0.003 in. (0.075 mm). The lining shall be cured at a temperature and for a length of time suitable to assure continuity of lining and elimination of solvents. The water absorption rate of the cured lining shall be less than 2% by the method specified in ASTM D570. Surfaces to be fluorocarbon polymer-lined shall be cleaned to remove all scale, oxidation, oil, etc., prior to application of the lining. Interior surfaces may be coated with electroless nickel prior to lining. Flue tubes may be covered with a minimum thickness of 0.006 in. (0.15 mm) of sheet copper prior to the application of the fluorocarbon polymer lining.

(f) *Amine or Polyamine Epoxy Linings*

(1) Amine or polyamine epoxy linings shall be of an analysis intended for use in potable hot water service, and the minimum thickness shall be 0.003 in. (0.075 mm). The lining shall be cured at a temperature and for a length of time suitable to assure continuity of lining and elimination of solvents. The water absorption rate of the cured lining shall be less than 2% by the method specified in ASTM D570. Surfaces to be epoxy lined shall be cleaned to remove all scale, oxidation, oil, etc., prior to application of the lining.

(2) The use of amine or polyamine epoxy linings shall be limited to electric water heaters with immersion type elements, storage tanks, and those surfaces of fired water heaters that are not directly heated by the products of combustion.

(g) *Thermally Sprayed Metallic Linings.* The material used for linings shall be any copper or copper alloy of sprayable quality. Prior to coating, the interior surfaces of the vessel or vessel parts shall be cleaned by grit blasting. The minimum lining thickness shall be 0.005 in. (0.13 mm). The process shall be controlled to ensure that the temperature of the surface being coated does not exceed 650°F (340°C).

(h) *Polymeric, Flexible Linings.* Materials used shall be listed by National Sanitation Foundation International (NSFI) as meeting the requirements of the Standard ANSI/NSF 14 for potable water service at a minimum temperature of 210°F (99°C). The water absorption rate of the material shall be less than 10% by the 2 hr

boiling water immersion test specified in ASTM D570. No reground material shall be used.

The minimum thickness of the lining shall be 0.020 in. (0.50 mm). The interior surfaces of the vessel shall be free of projections or discontinuities that exceed one-half the thickness of the fabricated liner. The installed liner shall be in contact with all interior surfaces of the vessel and free of folds or cracks after the hydrostatic test of [HLW-505](#). The design shall be such that:

(1) all transition parts, such as needed at vessel openings, shall be of compatible materials

(2) transition parts shall be designed so that any required brazing or welding of subsequent connections, if required, shall not damage the lining

(i) *Autocatalytic (Electroless) Nickel-Phosphorus Linings*. The composition shall be of an analysis suitable for use in potable hot water service. It shall conform to ASTM B733-90 SC3, Type 1, Class 1. The application shall be after all welding. The minimum thickness shall be 0.0003 in. (0.0075 mm). All surfaces to be lined shall be free of oxides, oil or other contaminants. The phosphorus content of the bath shall be at least 9%, but not over 13%. Following application, the vessel shall be drained and thoroughly rinsed with water.

(j) *Polyamide Polymer Linings*. Polyamide polymer linings shall be of an analysis intended for use in potable hot water service. The minimum applied thickness shall be 0.008 in. (0.2 mm). If a primer is used, the primer shall also be of an analysis intended for use in potable hot water systems.

(1) Surfaces to be polyamide polymer lined shall be cleaned to remove all scale, oxidation, oil, etc., prior to application of the lining.

(2) The lining shall be baked at a metal temperature and time consistent with the coating manufacturer's recommendation.

(3) The absorption rate of the finished lining shall be less than 3% by the method specified in ASTM D570.

(4) The use of polyamide polymer linings shall be limited to those surfaces that are not directly heated by products of combustion.

(k) *Baked Phenolic Linings*. Baked phenolic linings shall be of an analysis intended for use in potable hot water service, and the minimum thickness shall be 0.004 in. (0.1 mm). If multiple coats are used, each intermediate coat shall be cured at a minimum metal temperature of 250°F (120°C) for a length of time suitable to sufficiently harden the coat for further processing.

(1) Surfaces to be phenolic lined shall be cleaned to remove all scale, oxidation, oil, etc., before application of the lining.

(2) For final coated surfaces, the lining shall be cured at a metal temperature of 400°F to 425°F (205°C to 218°C) for 60 min to 90 min. The manufacturer shall inspect the lining to verify proper cure and minimum thickness and to

verify that it is free of discontinuities. Documentation of the basis of the temperature and time used and records of the inspection shall be available to the Inspector.

(3) The absorption rate of the cured lining shall be less than 2% by the method specified in ASTM D570.

HLW-201 PRIMARY PRESSURE PARTS MATERIAL

(23)

(a) Materials other than those described herein may not be used unless approved by the Boiler and Pressure Vessel Committee in accordance with Section II, Part D, Mandatory Appendix 5. The materials used for shells, heads, flues, headers, or tubes shall conform to one of the specifications listed in Section II and shall be limited to those listed in Section II, Part D, Tables 6B, 6C, and 6D. For plate material, a certificate of compliance or a material test report is required to verify that the chemical and mechanical properties are within the permissible range listed in Section II. Material in all other product forms shall be accepted as complying with its Section II specification when marked as required by (c) below. Material test reports shall be furnished by the mill of origin, except that any material that has lost its identification with a Section II specification, or that is ordered in small quantities, may be accepted, provided that it satisfies the provisions of [HLW-202](#).

(b) If a welded assembly is furnished as a part to the Manufacturer of the completed water heater vessel, a Manufacturer's Partial Data Report for Water Heaters and Storage Tanks [Form HLW-7](#) shall be provided by the parts Manufacturer. The parts Manufacturer shall comply with all applicable requirements of [Part HLW](#), including inspection by an Authorized Inspector.

(c) The material in (a) above shall have the identification marking required by the appropriate Section II specification. During subsequent steps in fabrication, a painted color identification or some other method acceptable to the Authorized Inspector shall be used for identification. The method used shall remain distinguishable, or be reapplied until the part(s) are affixed in their proper location on the water heater vessel, and until the material is part of a uniquely identifiable subassembly.

(d) Laser-welded fin tubes meeting the requirements of [HF-204.4](#) may be used in the construction of water heaters.

HLW-202 ACCEPTANCE OF UNIDENTIFIED OR SMALL QUANTITIES OF MATERIAL

If the identification of materials required by [HLW-201\(a\)](#) is unavailable, each piece of plate material, or each length of other material, shall be shown to meet the chemical requirements and mechanical properties of the Section II specification designated for the part for which

the material is to be used. The material shall be subjected to all required tests of the Section II specification. The manufacturer of the completed vessel shall verify that the material complies with the designated specification.

Testing shall be as in [HLW-202.1](#) and [HLW-202.2](#).

HLW-202.1 Plate. The chemical check analysis and physical tests shall be made as required in the designated specification, with the following modification: when the direction of rolling is not definitely known, two tension specimens shall be taken at right angles to each other from a corner of each plate, and two bend specimens shall be taken from the middle of adjacent sides of each plate. One tension specimen and both bend specimens shall meet the specification requirements.

HLW-202.2 Tubes, Pipe, Rods, Bars, and Shapes. Each length of tube, pipe, rod, bar, or shape shall be subjected to a chemical check analysis and physical tests to show that all the material is identified with a given heat or heat treatment lot, and that the material complies with the chemical and physical requirements of the designated specification.

HLW-202.3 Marking and Test Report. When the identity of material with a designated specification has been established in accordance with [HLW-202.1](#) or [HLW-202.2](#), each piece of material (except as alternatively provided in the material specification for tubes, pipes, rods, bars, or shapes) shall be marked or identified by the manufacturer or the testing agency by any method acceptable to the Authorized Inspector, giving the designated specification number and grade or type, and a serial S-number identifying the particular lot of material. A suitable test report shall be furnished, properly filled out, and certified by the manufacturer or testing agency. This report when accepted by the Authorized Inspector shall constitute authority to use the material.

HLW-203 MISCELLANEOUS PRESSURE PARTS MATERIAL

(a) Parts such as flanges, welding caps, welding necks, manhole frames, or manhole covers that are formed by casting, forging, rolling, or die forming, shall not require inspection, mill test reports, or Partial Data Reports. Standard pressure parts that comply with some ASME standard¹⁸ shall be constructed from materials listed in the accepted ASME standard to which the parts are made. Standard pressure parts that comply with a Manufacturer's standard¹⁹ shall be constructed from materials permitted under Section II. Such parts shall be marked with the name or trademark of the manufacturer. Such markings shall be considered as the manufacturer's certification that the product complies with the material specification and is suitable for service at the

rating indicated. A certificate of compliance or a material test report is not required.

(b) Carbon steel or cast iron pressure parts of small size, such as nozzles, internally threaded fittings, handhole frames, or handhole covers, for which it is difficult or impossible to obtain identified material, or that may be stocked and for which material test reports or certificates cannot be readily obtained, may be constructed from Section II materials other than those listed in Section II, Part D, Tables 6B, 6C, and 6D, provided they are suitable for the application. These parts may be identified in any permanent or temporary manner acceptable to the Authorized Inspector that will serve to identify the parts with the manufacturer's written listing. Marking of each individual part is not required. The manufacturer who certifies the completed vessel shall satisfy himself that such parts are suitable for the welding, fabrication, service, and test conditions of its design. The use of such parts shall be subject to the acceptance of the Authorized Inspector.

HLW-204 FLANGES AND PIPE FITTINGS

The following standards covering flanges and pipe fittings are acceptable for use under [Part HLW](#) in accordance with the requirements of [HLW-203](#). Pressure-temperature ratings shall be per the appropriate standard:

- (a) ASME B16.5, Flanges and Flanged Fittings
- (b) ASME B16.9, Factory-Made Wrought Steel Butt-welding Fittings
- (c) ASME B16.11, Forged Steel Fittings, Socket-Welding and Threaded
- (d) ASME B16.15, Cast Bronze Threaded Fittings
- (e) ASME B16.24, Bronze Pipe Flanges and Flanged Fittings
- (f) ASME B16.28, Wrought Steel Butt-welding Short Radius Elbows and Returns
- (g) ASME B16.42, Ductile Iron Pipe Flanges and Flanged Fittings

HLW-205 NONPRESSURE PART MATERIAL

Material for nonpressure parts, such as baffles, fins, external or internal hangers, supports, or insulating rings, need not conform to the specifications for the material to which they are attached or to a material specification permitted in [HLW-300](#) or [HLW-301](#); but, if welded, they shall be of weldable quality. The allowable stress value shall not exceed 80% of the maximum allowable stress permitted for similar material in Section II, Part D, Table 6A or Table 6B. Satisfactory performance of a specimen in such service shall not make the material acceptable for use in pressure parts of a vessel.

ARTICLE 3 DESIGN

HLW-300 DESIGN

(a) Water heaters are limited to a maximum allowable working pressure of 160 psi (1 100 kPa) and the maximum water temperature shall be 210°F (99°C). The maximum allowable working pressure for water heaters shall be not less than 100 psi (700 kPa).

(b) The maximum allowable working pressure of the water heater shall be established in accordance with the proof test provision of [HLW-500](#). As an alternative, stress values in Section II, Part D, Table 6B, Table 6C, or Table 6D may be used in calculations employing the available formulas when applicable to the geometry of the water heater or parts.

(c) The maximum allowable stress value in bending shall be 1½ times that permitted in tension and the maximum allowable stress value in compression shall be two times that permitted in tension.

(d) The temperature used in design shall not be less than the mean metal temperature (through the thickness) expected under operating conditions for the part considered. If necessary, the metal temperature shall be determined by computation using accepted heat transfer procedures or by measurements from equipment in service under equivalent operating conditions. Pressure parts subject to direct radiation and/or the products of combustion shall be designed to prevent flame impingement.

(e) Water heaters may be fired with oil, gas, or electricity.

(f) Water heaters and tanks built under the rules of [Part HLW](#) may be provided with cathodic protection.

(g) Water heaters used for deionized water fabricated of stainless steel listed in Section II, Part D, Table 6D may be built to [Part HLW](#) provided the maximum thickness does not exceed ½ in. (13 mm).

HLW-301 BASIS FOR ESTABLISHING STRESS VALUES IN SECTION II, PART D, TABLES 6C AND 6D

In the determination of allowable stress values for pressure parts, the Committee is guided by successful experience in service, insofar as evidence of satisfactory performance is available. Such evidence is considered equivalent to test data where operating conditions are

known with reasonable certainty. In the evaluation of new materials, it is necessary to be guided to a certain extent by the comparison of test information with similar data on successful applications of similar materials.

At any temperature below the creep range, the allowable stresses are established at no higher than the lowest of the following:

(a) ¼ of the specified minimum tensile strength at room temperature

(b) ¼ of the tensile strength at temperature

(c) ⅔ of the specified minimum yield strength at room temperature

(d) ⅔ of the yield strength at temperature

Section II, Part D, Table 6D provides two sets of allowable stress values for each austenitic stainless steel material listed. The higher values should be used only where slightly greater deformation is not in itself objectionable. The higher alternative allowable stresses are identified by a note. These stresses exceed two-thirds for austenitic stainless steel materials but do not exceed 90% of the minimum yield at temperature. These higher stresses are not recommended for the design of flanges and other strain sensitive applications.

HLW-302 MINIMUM THICKNESSES

The minimum thickness of sheet or plate material used for heads or shells in any lined or unlined water heater vessel shall not be less than ⅛ in. (3 mm) except cylindrical shells shall be not less than ⅜ in. (2.5 mm) when no portion of the shell is used for heating surface.

HLW-303 SHELLS UNDER INTERNAL PRESSURE

When the provisions of [HLW-501](#) to [HLW-504](#) are not used, the thickness and the maximum allowable working pressure of cylindrical shells, pipe, and headers shall be determined in accordance with the following formulas:

$$t = \frac{PR}{SE - 0.6P}$$

$$P = \frac{SEt}{R + 0.6t}$$

where

E = efficiency of longitudinal joint or ligament between tube holes, whichever is less. For welded joints, use the efficiency specified in [HLW-402](#). For seamless shells, use $E = 1$.

P = maximum allowable working pressure, psi (kPa) (but not less than 100 psi)

R = inside radius of cylinder, in. (mm)

S = maximum allowable stress value from Section II, Part D, Table 6A, Table 6B, Table 6C, or Table 6D, psi (MPa)

t = required wall thickness, exclusive of liner, in.

HLW-305 BLANK UNSTAYED DISHED HEADS, PRESSURE ON CONCAVE SIDE

HLW-305.1 General. When the provisions of [HLW-501](#) to [HLW-504](#) are not used, the required thickness at the thinnest point after forming of ellipsoidal and torispherical heads under pressure on the concave side (plus heads) shall be computed by the appropriate formulas in this paragraph.

(a) *Notations.* The notations used in this paragraph are defined as follows:

D = inside diameter of the head skirt; or inside length of the major axis of an ellipsoidal head; or inside diameter of a cone head at the point under consideration, measured perpendicular to the longitudinal axis, in. (mm)

E = lowest efficiency of any joint in the head; use the efficiency specified in [HLW-402](#). For seamless heads, use $E = 1$.

L = inside spherical or crown radius, in. (mm)

P = maximum allowable working pressure, psi (kPa) [but not less than 100 psi (700 kPa)]

S = maximum allowable stress value from Section II, Part D, Table 6A, Table 6B, or Table 6C, psi (MPa)

t = required wall thickness, exclusive of liner, in. (mm)

HLW-305.2 Ellipsoidal Heads. When the provisions of [HLW-501](#) to [HLW-504](#) are not used, the required thickness and the maximum allowable working pressure of a dished head of semiellipsoidal form, in which half the minor axis (inside depth of the head minus the skirt) equals one-fourth of the inside diameter of the head skirt, shall be calculated by the following formulas:

$$t = \frac{PD}{2SE - 0.2P}$$

$$P = \frac{2SEt}{D + 0.2t}$$

HLW-305.3 Torispherical Heads. When the provisions of [HLW-501](#) to [HLW-504](#) are not used, the required thickness and the maximum allowable working pressure of a torispherical head shall be calculated by the following formulas:

$$t = \frac{0.885PL}{SE - 0.1P}$$

$$P = \frac{SEt}{0.885L + 0.1t}$$

HLW-305.4 Inside Crown Radius of Unstayed Heads. The inside crown radius to which an unstayed formed head is dished shall be not greater than the outside diameter of the skirt of the head. The inside knuckle radius of a torispherical head shall be not less than 6% of the outside diameter of the skirt of the head but in no case less than three times the head thickness.

HLW-305.5 Hemispherical Heads. Because of the complexity of joint design, hemispherical heads are not permitted.

HLW-306 BLANK UNSTAYED DISHED HEADS, PRESSURE ON CONVEX SIDE

HLW-306.1 When the provisions of [HLW-501](#) to [HLW-504](#) are not used, unstayed dished heads with the pressure on the convex side shall have a maximum allowable working pressure equal to 60% of that for heads of the same dimension with the pressure on the concave side.

HLW-306.2 Hemispherical Heads. Because of the complexity of joint design, hemispherical heads are not permitted.

HLW-307 TUBES

When the provisions of [HLW-501](#) to [HLW-504](#) are not used, the thickness of seamless or welded tubes shall be in accordance with [HG-301.2](#).

HLW-308 OPENINGS

HLW-308.1 Single openings in water heaters do not require reinforcement under the following conditions:

(a) welded connections attached in accordance with the applicable rules and not larger than NPS 3 (DN 80) in shells or heads $\frac{3}{8}$ in. (10 mm) or less; NPS 2 (DN 50) in shells or heads over $\frac{3}{8}$ in. (10 mm)

(b) threaded, studded, or expanded connections in which the hole cut in the shell or head is not greater than NPS 2 (DN 50)

HLW-308.2 When the provisions of **HLW-501** to **HLW-504** are not used, all other openings shall be reinforced in accordance with **HG-321** of this Section.

(23) **HLW-309 TUBES ATTACHED BY EXPANDING**

(a) The tube hole in the head or tubesheet shall be formed either:

(1) to the full size diameter by a method that will not produce irregularities that would interfere with proper expanding and sealing, or

(2) to a lesser diameter, then enlarged to full diameter by a secondary drilling, cutting, or reaming operation to remove such irregularities.

The sharp edges of tube holes shall be taken off both sides with a file or other tool.

(b) The minimum thickness of any tubesheet with tubes installed by expanding shall be $\frac{3}{16}$ in. (5 mm).

HLW-310 STORAGE TANKS

HLW-310.1 Tank Construction. If a system is to utilize a storage tank that exceeds the capacity exceptions of **HLW-101**, the tank shall be constructed in accordance with the requirements of this Part; the requirements of Section VIII, Division 1; or the requirements of Section X. Regardless of the Code Section governing construction of the vessel, all storage tanks used in applications under this Part shall be provided with a corrosion-resistant lining or constructed with corrosion-resistant materials that are suitable for use in potable hot water at 210°F (99°C) and are marked for a maximum allowable working pressure of 160 psig (1 100 kPa) or less. Heat exchangers installed in HLW-marked vessels shall be made of corrosion-resistant materials.

(23) **HLW-310.2 Inspection Openings.** Storage tanks constructed to the rules of this Part shall be provided with suitable manhole, handhole, fitting, or other openings for internal inspection and cleaning. Manholes shall not be less than 12 in. × 16 in. (300 mm × 400 mm). Manholes in which internal pressure forces the cover plate against a flat gasket shall have a gasket bearing width of at least $\frac{11}{16}$ in. (17 mm).

(a) All vessels less than 18 in. (450 mm) and over 12 in. (300 mm) inside diameter shall have at least two inspection openings. Each inspection opening shall be either

(1) a handhole opening not less than 2 in. × 3 in. (50 mm × 75 mm)

(2) a plugged threaded opening not less than NPS 1½ (DN 40)

(b) All vessels with an inside diameter of 18 in. to 36 in. (450 mm to 900 mm), inclusive, shall have a manhole or at least two inspection openings. Each inspection opening shall be either

(1) a handhole not less than 2 in. × 3 in. (50 mm × 75 mm)

(2) a plugged threaded opening not less than NPS 2 (DN 50)

(c) All vessels with an inside diameter greater than 36 in. (900 mm) shall have a manhole or at least two inspection openings. Each inspection opening shall be either

(1) a handhole not less than 4 in. × 6 in. (100 mm × 150 mm)

(2) a flanged opening not less than 6 in. (150 mm) in diameter in a pipe

(d) When handholes or pipe plug openings are permitted for inspection openings in place of a manhole, one handhole or one pipe plug opening shall be in each head or in the shell near each head.

(e) Openings with removable heads, fittings, or cover plates that are intended for other purposes may be used in place of the required inspection openings provided they are at least equal to the size of the required inspection openings.

(f) A single opening with a removable head or cover plate may be used in place of all the smaller inspection openings provided it is of such size and location as to afford at least an equal view of the interior.

(g) Flanged and/or threaded connections from which piping, instruments, or similar attachments can be removed may be used in place of the required inspection openings provided the connections are of an equal size and afford an equal view of the interior.

(h) All inspection and access openings, flanges, fittings, removable heads, or cover plates and threaded plugs or caps shall comply with the requirements of this Part.

ARTICLE 4

DESIGN OF WELDMENTS

HLW-400 DESIGN OF WELDED JOINTS

HLW-401 General Requirements

All welds, fillet or full penetration, shall be made to a qualified welding procedure by qualified welders for each welding process employed (manual, semiautomatic, automatic), in accordance with the applicable provisions of Section IX to insure satisfactory penetration and fusion into the base metal to the root of the weld. It should be noted that the use of standard welding procedures is acceptable. All requirements for the use of these procedures shall be in accordance with Section IX. The use of these procedures shall be addressed in the manufacturer's or contractor's Quality Control Manual and shall be available for review by the Authorized Inspector. All members, prior to being welded, shall be properly fitted, aligned, and retained in position in accordance with the Procedure Specification for the welding procedure to be used.

Figure HLW-401.1
Butt Welding of Plates of Unequal Thickness

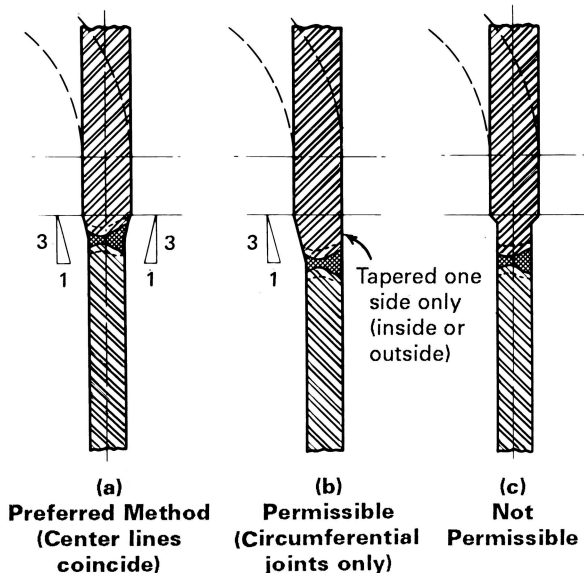

HLW-401.1 Butt Joints. Longitudinal or circumferential joints uniting plates of a drum, shell, or other pressure parts shall be butt joints. A butt joint shall be double welded butt or may have filler metal added from one side only, provided the weld penetration is complete.

(a) If there are two or more courses, the welded longitudinal joints of adjacent courses shall be not less than 6 in. (150 mm) apart.

(b) If the plates are of unequal thickness, at no point shall the plate on one side of the joint be offset with the plate on the other side of the joint in excess of one-fourth of the thickness of the thickest plate. The weld may be partly or entirely in the tapered section or adjacent to it as indicated in [Figure HLW-401.1](#).

HLW-401.2 Corner or Tee Joints. Unflanged heads or tubesheets of water heaters may be constructed by attaching unflanged heads or tubesheets to the shell by welding, provided

(a) corner or tee joints shall be as shown in [Figure HLW-401.2](#), sketch (a), (b), (c), (d), or (e).

(b) the head or tubesheet is supported by tubes.

(c) the welded joint for [Figure HLW-401.2](#), sketches (a), (b), and (c) is wholly within the shell and forms no part thereof. The throat of the fillet weld shall be not less than 0.7 times the thickness of the thinner plate.

(d) for [Figure HLW-401.2](#), sketches (b) and (d), the weld shall have full penetration, and for sketch (e), double full-fillet welds shall be provided.

HLW-401.3 Alignment Tolerance.

(a) The edges of plates at butt joints shall not be offset from each other at any point in excess of the amount specified in [Table HLW-401.3-1](#), where t is the plate thickness.

(b) Butt joints in heads and butt joints between cylindrical shells and hemispherical heads shall meet the requirements in (a) above for longitudinal joints in cylindrical shells.

HLW-401.4 Distortion.

(a) The cylinder or barrel of a drum or shell shall be circular at any section within a limit of 1% of the mean diameter, based on the differences between the maximum and minimum mean diameters at any section, and, if necessary to meet this requirement, shall be reheated,

**Figure HLW-401.2
Typical Corner Joints**

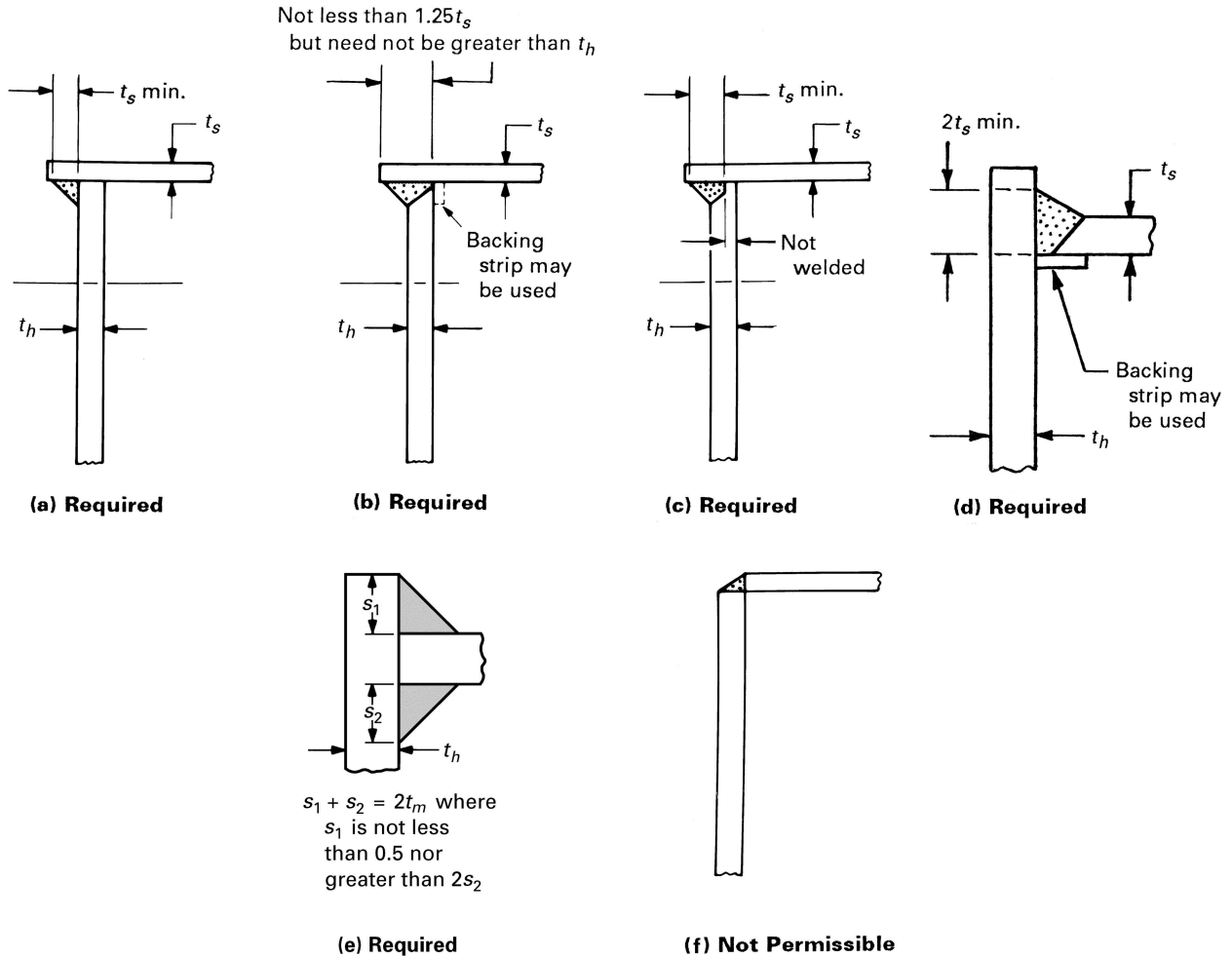

Legend:

t_h = nominal head thickness
 t_s = nominal shell thickness

**Table HLW-401.3-1
Alignment Tolerance**

Plate Thickness, t , in. (mm)	Direction of Joints in Cylindrical Vessels	
	Longitudinal	Circumferential
Up to $\frac{1}{2}$ (13), incl.	$\frac{1}{4}t$	$\frac{1}{4}t$
Over $\frac{1}{2}$ to $\frac{3}{4}$ (13 to 19), incl.	$\frac{1}{8}$ in. (3.0 mm)	$\frac{1}{4}t$
Over $\frac{3}{4}$ (19)	$\frac{1}{8}$ in. (3.0 mm)	$\frac{3}{16}$ in. (5.0 mm)

rerolled, or reformed. To determine the differences in diameters, measurements may be made on the inside or the outside. For vessels with longitudinal lap joints,

the permissible difference in inside diameters may be increased by the nominal plate thickness.

(b) Cylindrical furnaces and other cylindrical parts subjected to external pressure shall be rolled to a circle with a maximum permissible deviation from the true circle of not more than $\frac{1}{4}$ in. (6 mm).

HLW-402 Joint Efficiencies

The following joint efficiencies E are to be used in the formulas of this Section (i.e., HLW-303 and HLW-305) for joints completed by an arc or gas welding process:

(a) $E = 85\%$ for full penetration butt joints as attained by double welding or by other means, which will obtain the same quality of deposited weld metal on the inside and

outside weld surfaces, to provide complete joint penetration and assurance that the weld grooves are completely filled (HLW-401.1). Welds that use metal backing strips that remain in place are excluded.

(b) $E = 80\%$ for full penetration single-welded butt joints with backing strips other than those included in (a) above.

HLW-402.1 Joint Efficiencies for External Pressure Design. Joint efficiency E factors are not required to be used when the part is designed for external pressure only.

HLW-411 Heads or Tubesheets Attached by Welding

Typical water heater welded joints are shown in Figure HLW-411.

HLW-411.1 Flanged heads or tubesheets of water heaters attached by butt welding shall be in accordance with Figure HLW-415, sketch (d) or (e).

HLW-411.2 Flanged heads or tubesheets of water heaters may be constructed by attaching an outwardly or inwardly flanged head or tubesheet to the shell by fillet welding, provided

(a) inwardly flanged head or tubesheets are full fillet welded [see Figure HLW-415, sketch (a)]

(b) the joint attaching an outwardly flanged head or tubesheet shall be in accordance with Figure HLW-415, sketch (b) or (c)

(d) When openings are flanged for tubes as shown in Figure HLW-413, sketch (a), (b), or (e), flanges shall extend parallel to the tube for a minimum distance equal to the tube thickness.

(e) Where exposed to gases of greater than 850°F (450°C), head flanges shall conform to the limitations of Figure HLW-413.

(f) When the temperature of the gases is normally 850°F (450°C) or less, the length of flange or tube may extend beyond the limits of Figure HLW-413.

HLW-415 Head-to-Shell Attachments

Ellipsoidal, torispherical, and other types of formed heads, concave or convex to the pressure shall have the following requirements as to skirt length.

(a) An ellipsoidal or torispherical head that is attached to a shell by a butt joint as shown in Figure HLW-415, sketch (e), need not be provided with a skirt when the nominal head thickness does not exceed $1\frac{1}{4}$ times the nominal shell thickness. When the nominal head thickness exceeds $1\frac{1}{4}$ times the nominal shell thickness, a skirt shall be provided having a length not less than 3 times the nominal head thickness or $1\frac{1}{2}$ in. (38 mm), whichever is smaller. When a skirt is used, it shall meet the requirements for shell thickness in HLW-301.

(b) Ellipsoidal or torispherical heads, concave or convex to pressure, that are to be fitted inside or over a shell (lap joint) shall have a skirt of at least 3 times the nominal head thickness, but in no case less than 1 in. (25 mm).

(c) Shells and heads may be attached to shells or heads using a butt weld with one plate edge offset as shown in Figure HLW-415, sketch (d). The weld may be deposited on the inside of the vessel only when the weld is accessible for inspection after the vessel is completed.

HLW-420 Openings in Welds

Any type of opening that meets the requirements for reinforcement given in HG-321 may be located in a butt-welded joint.

HLW-430 Welded Connections

HLW-430.1 Strength of Attachment Welds. Nozzles, other connections, and their reinforcement may be attached to a water heater by arc or gas welding. Sufficient welding shall be provided on either side of the line through the center of the opening parallel to the longitudinal axis of the shell to develop the strength of the shell as prescribed in HG-327 through shear or tension in the weld, whichever is applicable. The strength of groove welds shall be based on the area subjected to shear or to tension. The strength of fillet welds shall be based on the area subjected to shear, computed on the

(23) HLW-413 Tubes Attached by Welding

(a) The edge of the plate at the tubesheet hole may be beveled or recessed to a depth at least equal to the thickness of the tubes. Where the plate is beveled or recessed, the projection of the tubes beyond the tube sheet shall not exceed a distance equal to the tube thickness. The depth of any bevel or recess shall not be less than the tube thickness or $\frac{1}{8}$ in. (3 mm), whichever is greater, nor more than one-third of the tubesheet thickness.

(b) Where no bevel or recess is employed, tubes shall extend beyond the tubesheet not less than 1.5 times the tube thickness, nor more than 3 times the sum of the thickness of the head plus the thickness of the tube [see Figure HLW-413, sketch (d)].

(c) For tubes attached using laser beam welding, the minimum tube extension may be smaller than what is required in (b) provided the tube extends at least through the tubesheet. In addition, the welding procedure and the performance qualification shall be performed in accordance with Section IX, QW-193, and the required depth of penetration of the tube-to-tubesheet weld shall be at least 1.25 times the tube thickness.

Figure HLW-411 Typical Water Heater Welded Joints

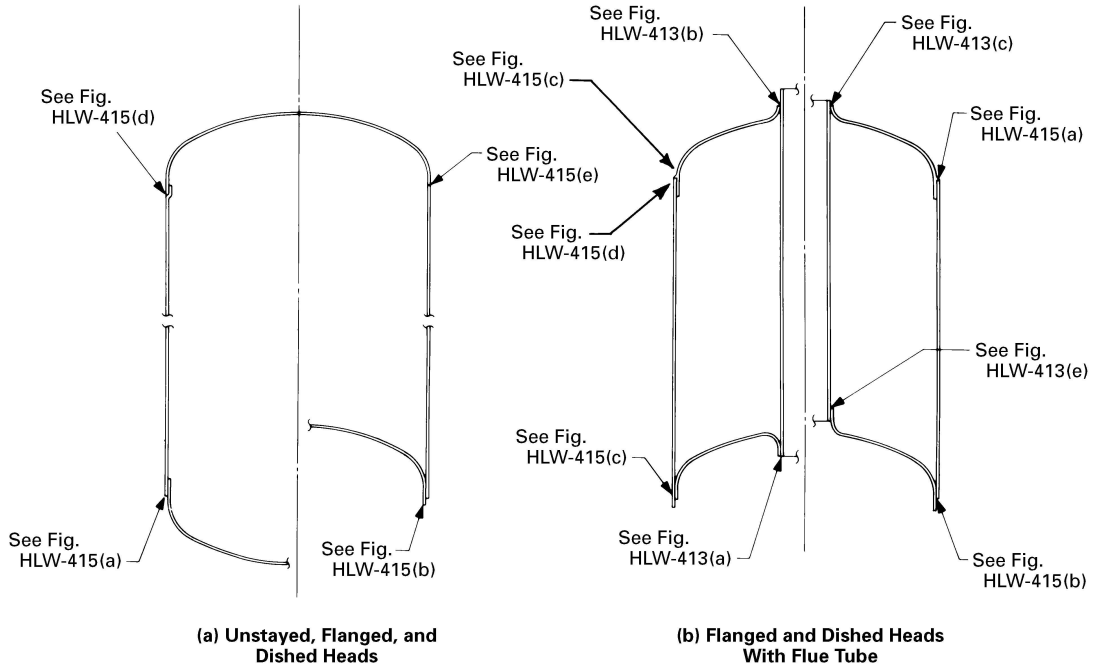
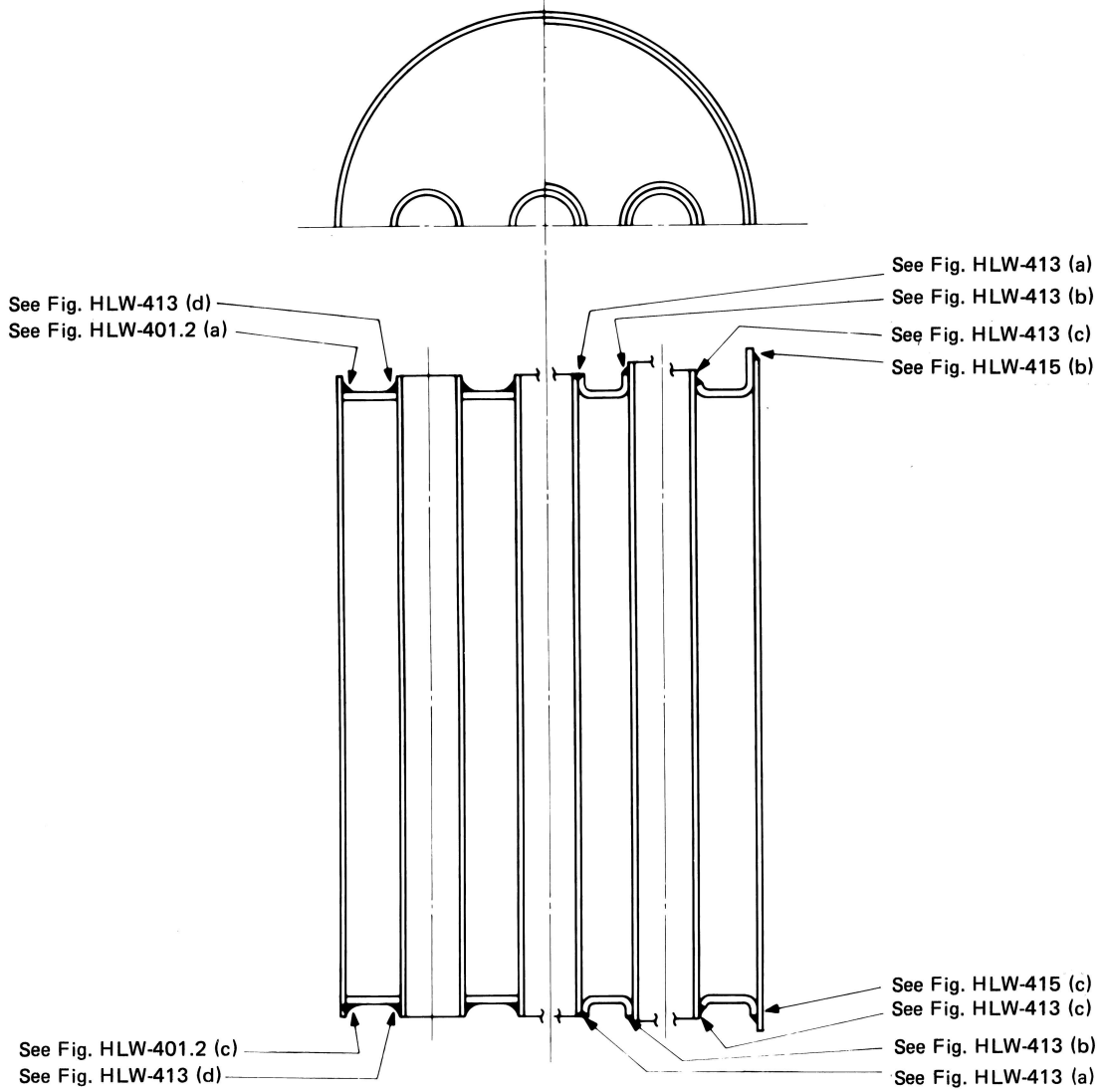
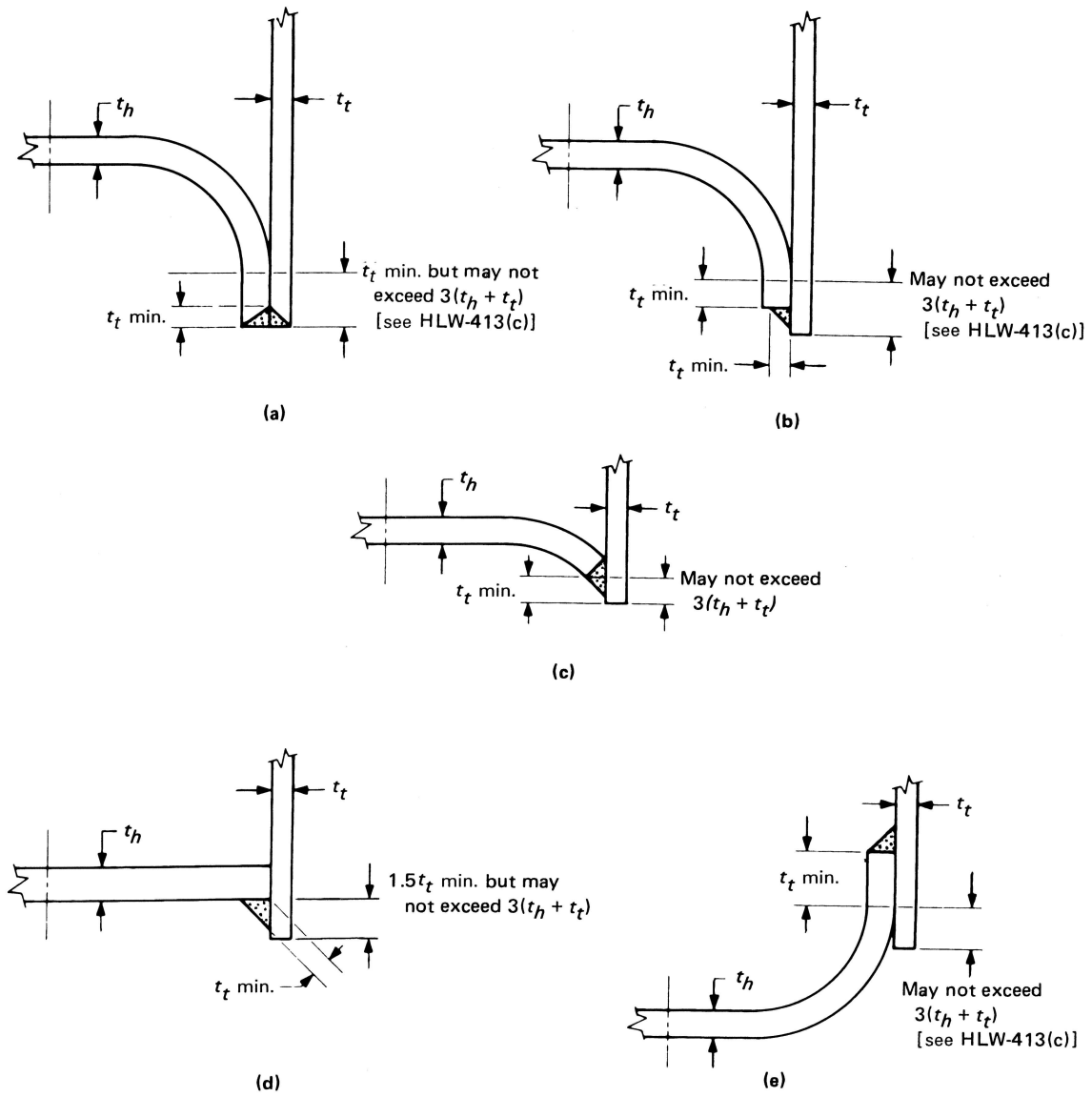

Figure HLW-411
Typical Water Heater Welded Joints (Cont'd)



(c) Unflanged and flanged flat heads with multiple heads

Figure HLW-413
Tubes Attached by Welding



Legend:

t_h = nominal head thickness

t_t = nominal tube thickness

**Figure HLW-415
Heads Attached to Shells**

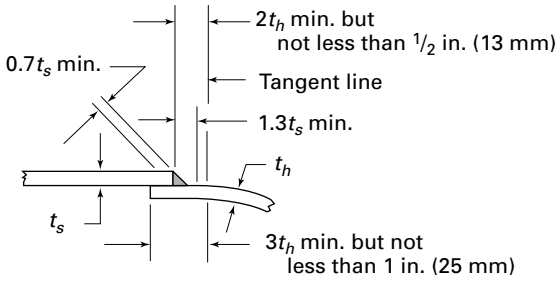

(a) Single Fillet Lap Weld

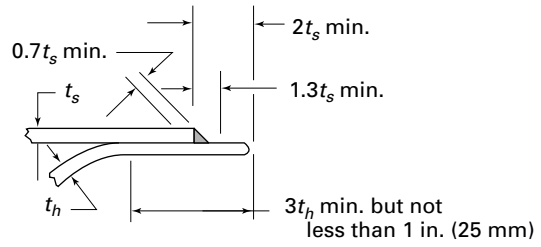

(b) Single Fillet Lap Weld

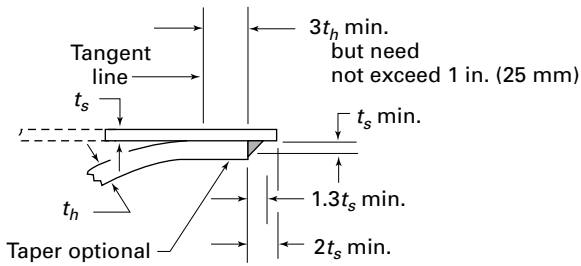

(c) Single Fillet Lap Weld

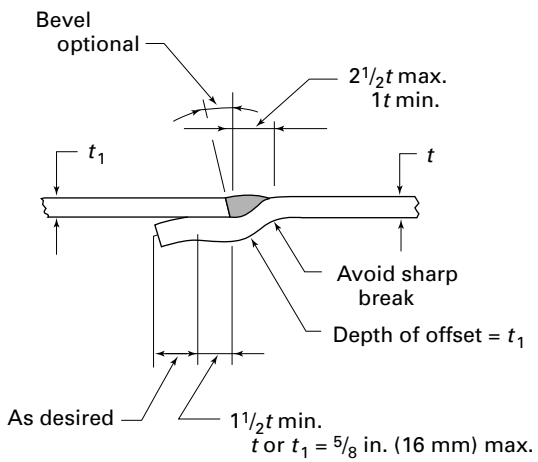

(d) Butt Weld With One Plate Edge Offset

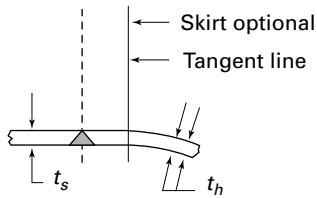

When t_h is equal to or less than $1.25t_s$

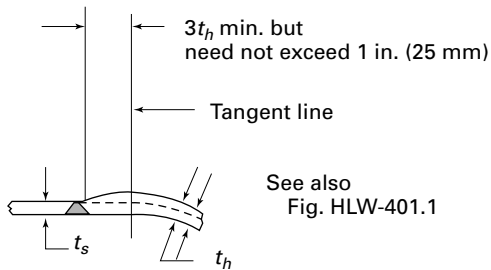

When t_h exceeds $1.25t_s$

(e) Butt Weld

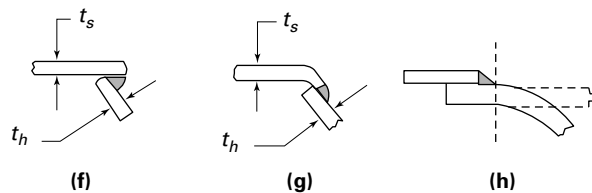

Details (f), (g), and (h) are not permissible.

Legend:

t_h = nominal head thickness
 t_s = nominal shell thickness

minimum leg dimension. The inside periphery of a fillet weld shall be used in computing its length.

HLW-430.2 Stress Values for Weld Metal. The allowable stress values for groove and fillet welds and for shear in nozzle necks in percentages of stress values for the vessel material are as follows:

Factor	Percentage of Stress Values, %
Nozzle wall	70
Groove weld tension	74
Groove weld shear	60
Fillet weld shear	49

GENERAL NOTE: These values are obtained by combining the following factors: 87½% for combined end and side loading, 80% for shear strength, and the applicable joint efficiency factors.

HLW-431 Minimum Requirements for Attachment Welds

HLW-431.1 General. The location and minimum size of attachment welds for nozzles and other connections shall conform to the requirements in this paragraph.

(a) *Notations.* The notations used in this paragraph and in [Figure HLW-431.1](#) are defined as follows:

- t = nominal thickness of shell or head
- t_1, t_2 = not less than $\frac{1}{3}t_{\min}$ or $\frac{1}{4}$ in. (6 mm) and $t_1 + t_2$ not less than $1\frac{1}{4}t_{\min}$
- t_c = the smaller of $\frac{1}{4}$ in. (6 mm) or $0.7t_n$ (inside corner welds may be further limited by a lesser length of projection of the nozzle wall beyond the inside face of the water heater wall)
- t_e = thickness of reinforcement element
- t_{\min} = the smaller of $\frac{3}{4}$ in. (19 mm) or the thickness of either of the parts joined by a fillet, single-bevel, or single-J weld, in. (mm)
- t_n = nominal thickness of nozzle wall
- t_w = dimension of partial-penetration attachment welds (fillet, single-bevel, or single-J), measured as shown in [Figure HLW-431.1](#)

HLW-431.2 Inserted Nozzles Without Added Reinforcement Elements.

(a) Nozzles inserted into or through a hole cut in the shell and without additional reinforcement elements shall be attached by a full-penetration groove weld or by two partial penetration welds, one on each face of the shell. Permissible types of welds are shown in [Figure HLW-431.1](#), sketches (a) through (h).

(b) Backing strips shall be used with full penetration welds deposited from one side only when the shell thickness is over $\frac{3}{8}$ in. (10 mm) or when complete joint penetration cannot be verified by visual inspection. The two partial penetration welds may be any desired combination

of fillet, single-bevel, and single-J welds. The dimension t_w of each weld shall be not less than $\frac{1}{4}$ in. (6 mm) or $0.7t$ and their sum shall be not less than $1\frac{1}{4}t_{\min}$ (see [Figure HLW-431.1](#)).

HLW-431.3 Inserted Nozzles With Added Reinforcement. Inserted-type nozzles having added reinforcement in the form of one or more separate reinforcement plates shall be attached by welds at the nozzle neck periphery and at the outer edge of each reinforcement plate. The weld at the outer edge of each reinforcement plate shall be a fillet weld with a minimum throat dimension of $\frac{1}{2}t_{\min}$.

HLW-431.4 Nozzles With Integral Reinforcement. Nozzles and other connections having integral reinforcement in the form of extended necks or saddle-type pads shall be attached by a full-penetration weld or by means of a fillet weld along the outer edge and a fillet, single-bevel, or single-J weld along the inner edge. The throat dimension of the outer weld shall be not less than $\frac{1}{2}t_{\min}$. The dimension t_w of the inner weld shall be not less than $0.7t_{\min}$ [see [Figure HLW-431.1](#), sketch (h)].

HLW-431.5 Fittings With Internal Threads and Studded Pads. The attachment of internally threaded fittings and studded pads shall meet the following requirements:

(a) Except as provided for in (b) below, internally threaded fittings shall be attached by a full-penetration groove weld or by two fillet or partial penetration welds, one on each face of the water heater wall. The minimum weld dimensions shall be as shown in [Figure HLW-431.5](#), sketches (u), (v), (w), and (x).

(b) Internally threaded fittings or equivalent bolting pads not exceeding NPS 4 (DN 100) may be attached by a fillet weld deposited from the outside only, having the minimum dimensions shown in [Figure HLW-431.5](#), sketches (a) through (l). Fittings or studded pads that are not subject to a bending load and that will be plugged, such as those for thermostats, anode rods, drain valves, cleanouts, and heating elements, may be attached to water heater vessels having a thickness not greater than $\frac{3}{8}$ in. (10 mm) by a fillet weld deposited from the outside only having the minimum dimensions shown in [Figure HLW-431.5](#), sketch (y). The maximum size opening in the water heater vessel shall be $5\frac{3}{8}$ in. (136 mm) in any direction but not greater than one-half the vessel diameter.

(c) Flange-type fittings not exceeding NPS 2 (DN 50) as shown in [Figure HLW-431.5](#), sketch (z) may be attached without additional reinforcement other than that in the fitting and its attachments, provided all of the following conditions are met:

- (1) the water heater wall thickness shall not exceed $\frac{3}{8}$ in. (10 mm)

Figure HLW-431.1
Some Acceptable Types of Welds for Fittings, Nozzles, and Other Connections to Shells and Head

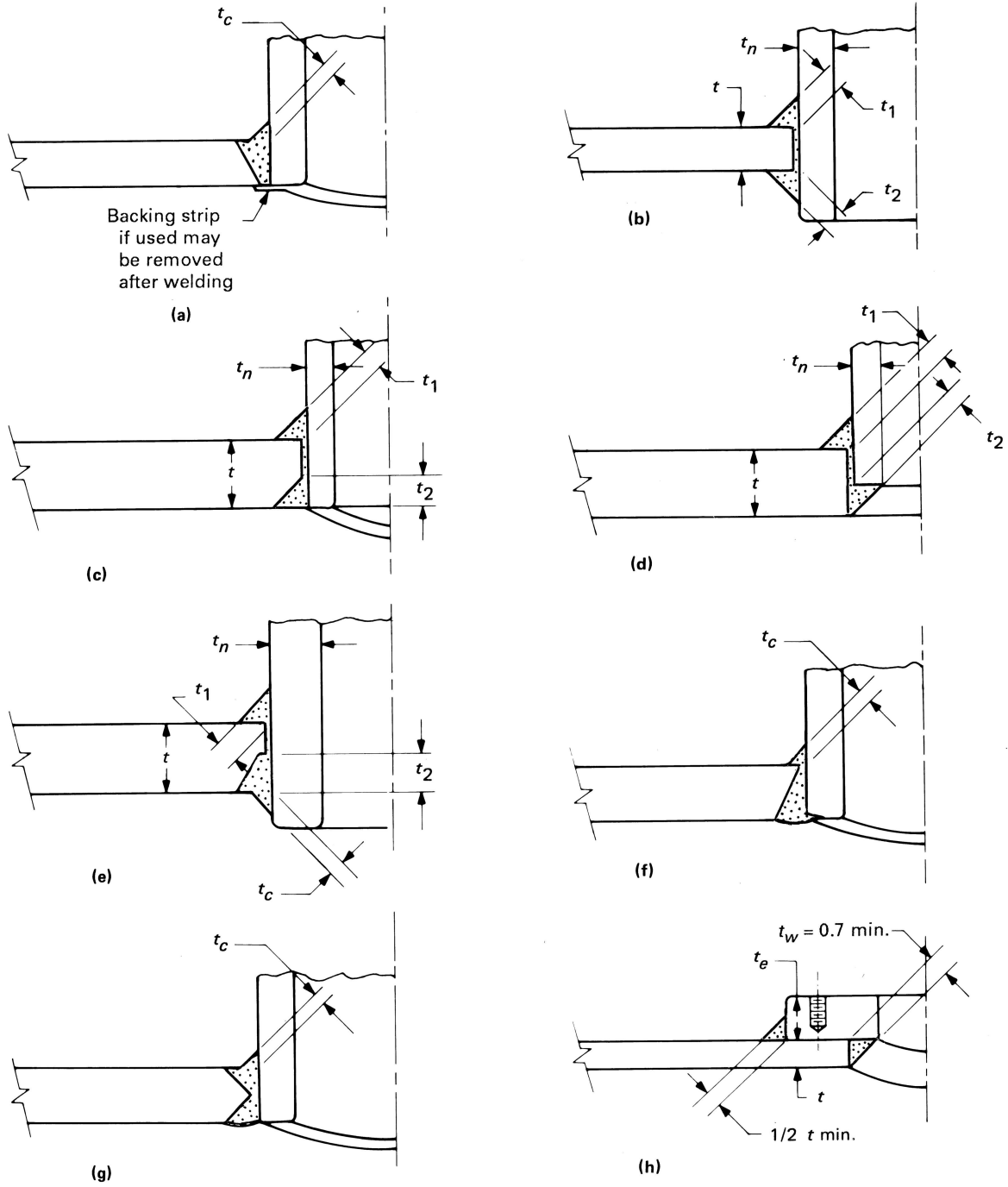

GENERAL NOTE: $t_1 + t_2 = 1\frac{1}{4}t \text{ min.}$; t_1 or t_2 not less than the smaller of $\frac{1}{4} \text{ in.}$ or $0.7t \text{ min.}$

Figure HLW-431.5
Some Acceptable Types of Welds for Fittings, Nozzles, and Other Connections to Shells and Head

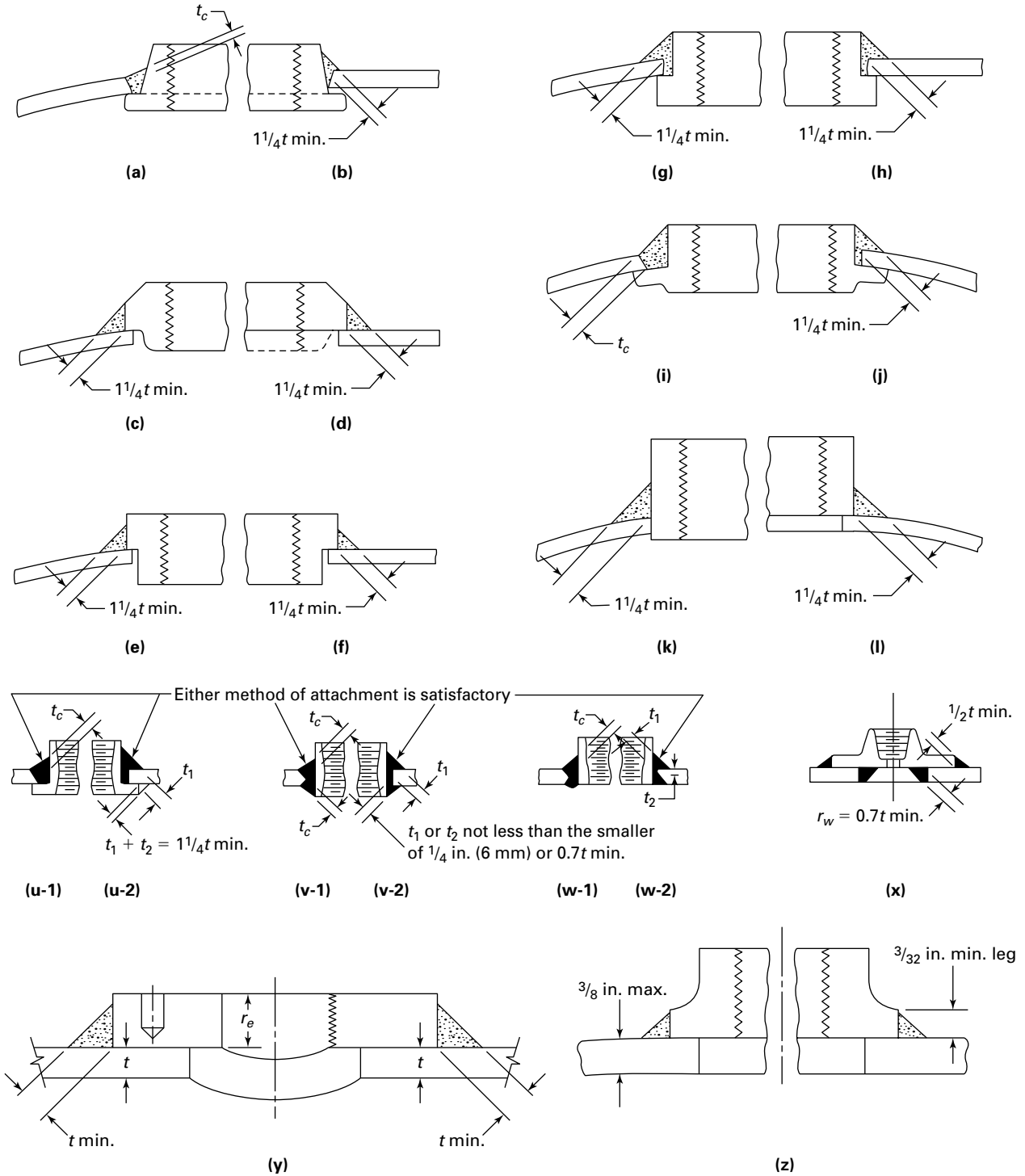

(2) the minimum fillet leg shall be $\frac{3}{32}$ in. (2.5 mm)

(3) the opening in the water heater wall shall not exceed the outside diameter of the nominal pipe plus $\frac{3}{4}$ in. (19 mm)

HLW-431.6 Fittings Attached by Resistance Welding. Resistance welding may be used for the attachment of fittings under the following limitations and requirements:

(a) The welding process utilized shall be limited to projection welding.

(b) Materials used in resistance welded parts shall be limited to a maximum carbon content of 0.15%.

(c) The thickness t shall not exceed $\frac{5}{16}$ in. (8 mm), and the fitting shall not exceed NPS 2 (DN 50).

(d) The maximum allowable working pressure for a vessel with fittings attached by resistance welding shall be established by a proof test in accordance with [HLW-500](#).

(e) In lieu of the Procedure and Performance Qualification requirements of Section IX, the following requirements shall be met:

(1) *Workmanship Samples*

(-a) Three welded specimens of each combination of fitting size and base metal thickness employed shall be made immediately before and after the welding of the fittings for the proof test vessel. These test specimens shall be representative of the manufacturing practice employed in the attachment of the fittings to the proof test vessel. Sufficient base metal shall overlap the fitting to allow securement for the tensile test.

(-b) These welded specimens shall be subjected to tensile loading. Each specimen shall pass the tensile test by shearing the fitting or the base metal. Separation at the weld interface shall constitute failure. Any failure shall require a repeat of the workmanship sample test as herein required.

(-c) All pertinent information obtained from the foregoing tests shall be recorded. These samples and data constitute workmanship samples that shall be available for comparison with quality control specimens that are made during production.

(2) *Machine Settings and Controls*

(-a) The resistance welding machine settings and process control parameters used in the attachment of the fittings to the proof test vessel and the workmanship samples shall be recorded. Except for minor variations and adjustments as permitted in the above parameters, the applicable settings shall be used in the fabrication of all vessels in a given production run.

(-b) The machine settings and control shall be verified by a test sample prior to the start of daily operations, after any service or adjustment is done on the welding equipment, and with every change in material or nominal thickness.

(3) *Records.* Records shall be kept of all data obtained from tests of the proof test vessel, the workmanship samples, the welding machine settings, the welding procedure, and process control parameters.

(4) If resistance welding machines other than those used for the initial proof test vessel and workmanship samples are to be used in production, each additional machine and welding procedure shall be qualified in full accordance with [\(e\)\(1\)](#), [\(e\)\(2\)](#), and [\(e\)\(3\)](#) above.

HLW-431.7 Stud Welds for Covers. Arc stud welding and resistance stud welding, as defined in [E-102](#), where the pressure exerts a tensile load on the studs, may be used for the attachment of bolted unstayed flat heads, cover plates and blind flanges, handholes and manholes, with the following limitations:

(a) Studs attached by stud welding shall not be in direct contact with products of combustion or flue gases.

(b) Where the pressure exerts a tensile load on the studs, a full-face gasket must be used on flat heads, cover plates, and blind flanges attached by stud welding.

(c) The minimum size stud used shall be not less than $\frac{1}{4}$ in. (6 mm) nominal diameter and the maximum size shall not exceed $\frac{7}{8}$ in. (22 mm) nominal diameter.

(d) The type of stud shall be limited to round externally threaded studs.

(e) Base metal shall be of ferrous material specification as permitted by this Section, and the base metal must be thick enough to prevent burn through.

(f) Stud material for arc stud welding and resistance stud welding of carbon steel shall be low carbon steel of an acceptable material in this Section and with a carbon maximum of 0.27% and with a minimum tensile strength of 60,000 psi (400 MPa).

(g) The maximum spacing of studs shall not exceed 12 times the nominal diameter of the stud.

(h) The maximum allowable stress for the stud shall be 7,800 psi (54 MPa) based on the smallest cross-sectional area (i.e., the root of the thread).

HLW-431.8 Stud Welds for Internally Threaded Fittings. Arc stud welding and resistance stud welding, as defined in [E-102](#), may be used for the mechanical attachment of fittings used to secure piping to vessel shells and heads with the following limitations.

(a) Mechanically attached internally threaded fittings shall be limited to a maximum NPS 3 (DN 80) and shall be secured by a minimum of four studs.

(b) Daily production weld tests shall be per [HLW-460.5](#).

(c) Stud welds used for the mechanical attachment of internally threaded fittings shall meet the provisions of [HLW-431.7](#).

(d) Gaskets for internally threaded fittings mechanically attached using arc- or resistance-welded studs may be of the flat or ring type, made of a material suitable for service at a minimum of 210°F (99°C). When ring-type

gaskets are employed, a suitable recess shall be provided in the fitting to accommodate the gasket.

(e) The maximum allowable working pressure for a vessel with internally threaded fittings mechanically attached using arc- or resistance-welded studs shall be established by proof test in accordance with [HLW-500](#). Each size of the proposed connection shall be tested including the gasket method, studs, and internally threaded fittings.

HLW-431.9 Friction Welding. Materials joined by the inertia and continuous drive friction welding processes shall be limited to material assigned P-Numbers in Section IX and shall not include rimmed or semikilled steel.

HLW-432 Brazed Connections for Copper Lined Vessels

Brazing shall meet the applicable requirements of [Part HF, Subpart HB, Articles 10 through 15](#), inclusive. Some acceptable brazed connections are as shown in [Figure HLW-432.1](#).

HLW-440 Welding Processes

The welding processes that may be used under this Part are restricted to the following:

(a) Arc or gas welding processes are restricted to shielded metal arc, submerged arc, gas metal arc, gas tungsten arc, plasma arc, atomic hydrogen metal arc, laser beam, electron beam, oxyhydrogen, and oxyacetylene.

(b) Pressure welding processes are restricted to flash, induction, resistance, pressure thermit, pressure gas, and inertia and continuous drive friction welding.

(c) Definitions are given in Section IX, which includes variations of these processes.

HLW-450 Welding Qualifications

Unless otherwise specified in this Part the procedures, the welders, and the welding operators used in welding pressure parts and in joining nonpressure parts (attachments) to pressure parts shall be qualified in accordance with Section IX.

Some linings require an elevated temperature for proper application. These elevated temperatures are not to be considered a form of heat treatment for welding procedure qualification.

(23) HLW-451 Production Work Qualifications

(a) No production work shall be undertaken until the procedures, the welders, and the welding operators have been qualified, except that performance qualification by radiography, in conformance with Section IX, QW-304 for welders or QW-305 for welding operators, may be

performed within the first 3 ft (1 m) of the first production weld.

(b) Welders, including brazers, and welding and brazing operators not in the employ of the manufacturer (Certificate of Authorization Holders) may be used to fabricate water heaters or parts thereof constructed in accordance with the Section, provided all of the following conditions are met:

(1) All Code construction shall be the responsibility of the Manufacturer.

(2) All welding shall be performed in accordance with the Manufacturer's welding procedure specifications that have been qualified by the Manufacturer in accordance with the requirements of Section IX and this Section.

(3) All welders shall be qualified by the Manufacturer in accordance with the requirements of Section IX and this Section.

(4) The Manufacturer's quality control system shall include as a minimum:

(-a) a requirement for complete and exclusive administrative and technical supervision of all welders by the Manufacturer

(-b) evidence of the Manufacturer's authority to assign and remove welders at his discretion without involvement of any other organization

(-c) a requirement for Assignment of Welder Identification symbols

(-d) evidence that this program has been accepted by the Manufacturer's Authorized Inspection Agency that provides the inspection service

(5) The Manufacturer shall be responsible for Code compliance of the completed vessel or part, including Certification Mark and providing Manufacturer's Data Reports properly completed and certified by the Inspector.

HLW-452 Interchange of Qualifying Tests Among Manufacturers Prohibited

The performance qualification tests for welders and welding operators conducted by one manufacturer or contractor shall not qualify a welder or welding operator to do work for any other manufacturer or contractor.

HLW-453 Maintenance of Records of Qualifications and Identifying Marks

The Manufacturer or contractor shall maintain qualification records of the welding procedures and welders and welding operators employed by him showing the date and results of test and the identification mark assigned to each welder. These records shall be certified to by the Manufacturer or contractor by signature or some other method of control in accordance with the Manufacturer's quality control system, and be accessible to the Inspector. The welder or welding operator shall

Figure HLW-432.1
Some Acceptable Types of Brazed Fittings, Nozzles, and Other Connections to Copper-Lined Shells and Heads

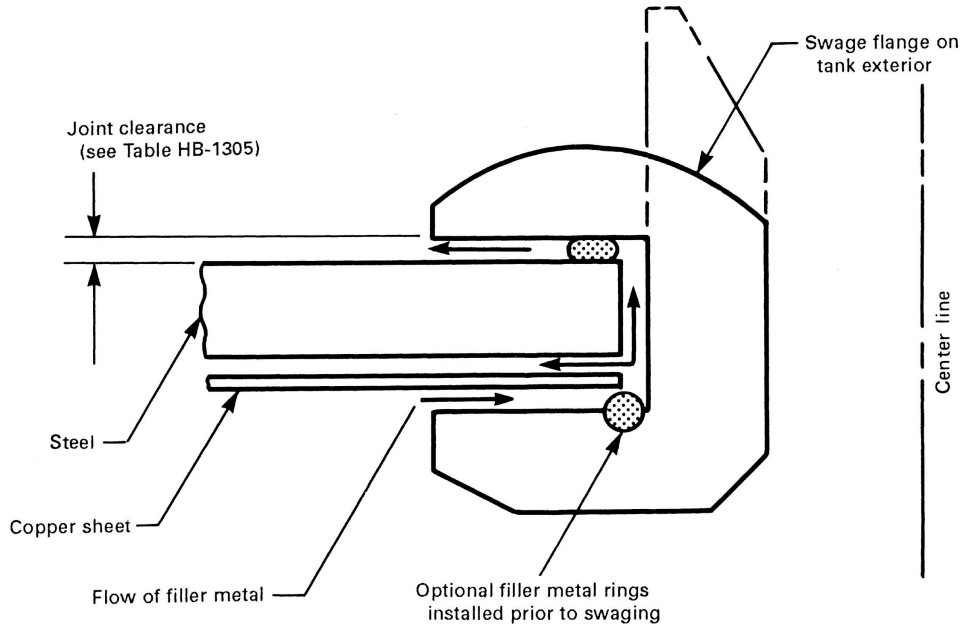

(a)

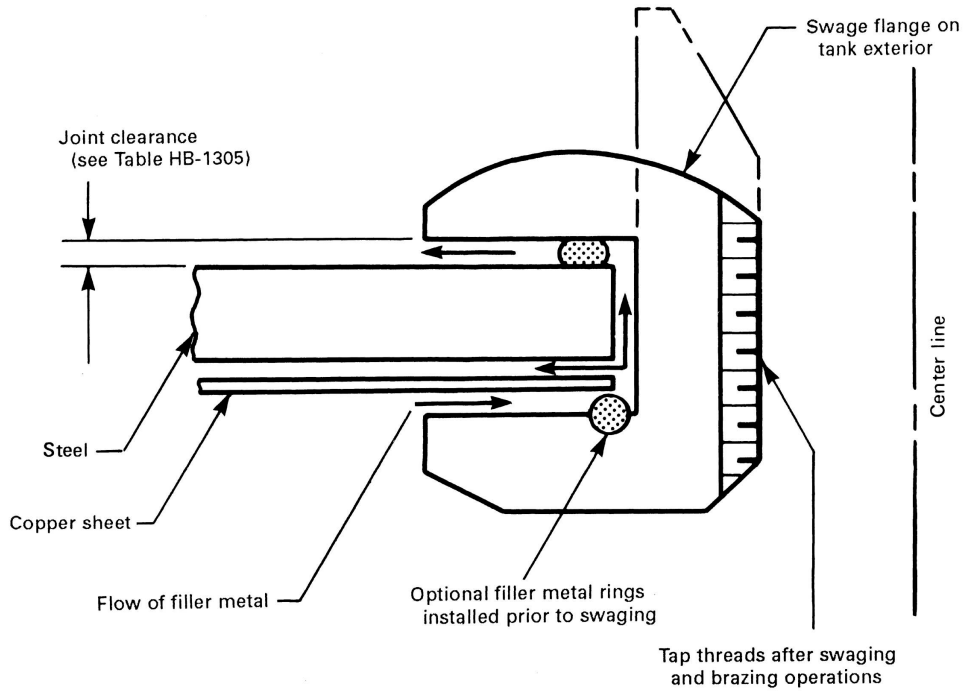

(b)

stamp his identification mark on or adjacent to all welded joints made by him at intervals of not greater than 3 ft (0.9 m), or the Manufacturer shall keep a record of the welded joints on a water heater vessel and the welders and welding operators used in making the joints.

HLW-454 Posthydrotest Welding of Nonpressure Parts to Pressure Parts

Nonpressure parts may be welded to pressure parts after the hydrostatic test has been performed as set forth in [HLW-505](#), provided the following criteria are met:

(a) The material requirements shall comply as follows:

(1) The pressure part material is limited to P-No. 1, Group 1 or 2 materials.

(2) The nonpressure attachment material is limited to carbon steel with a carbon content not exceeding 0.20% or any P-No. 1 material.

(3) When the nonpressure attachment material is other than P-No. 1, a minimum 200°F (93°C) preheat shall be applied when the pressure part thickness exceeds $\frac{3}{4}$ in. (19 mm).

(b) The attachment is done by stud welding, or by fillet welding where the throat of the weld does not exceed the lesser of 1.5 times the thickness of the pressure part or $\frac{1}{4}$ in. (6 mm).

(c) The completed weld is inspected by the Authorized Inspector.

(d) The Manufacturer's Data Report Form shall be signed only after the completion of the welding.

HLW-460 Specific Welding Requirements

HLW-460.1 Finished Longitudinal and Circumferential Joints.

(a) Butt-welded joints shall have complete penetration and full fusion. The surface of the weld may be left as-welded provided the weld is free of coarse ripples, grooves, overlaps, abrupt ridges, or valleys. A reduction in thickness due to the welding process is acceptable provided all of the following conditions are met:

(1) The reduction in thickness shall not reduce the material of the adjoining surfaces below the minimum required thickness at any point.

(2) The reduction in thickness shall not exceed $\frac{1}{32}$ in. (0.8 mm) or 10% of the nominal thickness of the adjoining surface, whichever is less.²³

HLW-460.2 Fillet Welds. In making fillet welds, the weld metal shall be deposited in such a way that adequate penetration into the base metal at the root of the weld is secured. The reduction of the thickness of the base metal due to the welding process at the edges of the fillet weld shall meet the same requirements as for butt welds [see [HLW-460.1](#)].

HLW-460.3 Double-Welded Butt Joints. Before applying weld metal on the second side to be welded, the root of double-welded butt joints shall be prepared by suitable methods such as chipping, grinding, or thermal gouging, so as to secure sound metal at the base of weld metal deposited on the face side, except for those processes of welding by which proper fusion and penetration are otherwise obtained and by which the root of the weld remains free from impurities.

HLW-460.4 Repair of Weld Defects. Visible defects, such as cracks, pinholes, and incomplete fusion, and defects detected by leakage tests shall be removed by mechanical means or by thermal grooving processes, after which the joint shall be rewelded and reexamined.

HLW-460.5 Stud Welding. In the case where arc stud welding and resistance stud welding is used to attach load carrying studs, a production stud weld test of the procedure and welding operator shall be performed on five studs, welded and tested in accordance with either the bend or torque stud weld testing described in Section IX as follows:

(a) prior to start of daily operation if used continuously on units of similar construction

(b) prior to the start of application to a given unit when not used continuously

(c) after adjustment or servicing is done on welding equipment

HLW-460.6 Procedure and Performance Qualification Tests and Material Requirements for Stud Welding.

Procedure and performance qualification tests for stud welds shall be made in accordance with Section IX. Further requirements for stud welding are as follows:

(a) Metallic coatings (such as cadmium plating) if used shall not be within $\frac{1}{2}$ in. (13 mm) from the weld end of the stud.

(b) The base metal must be above 50°F (10°C) during the welding process.

HLW-460.7 Stud Welding. In the case where stud welding and resistance stud welding are used for joining nonpressure bearing attachments, which have essentially no load carrying function (such as extended heat transfer surfaces, insulation attachment pins, etc.), to pressure parts by any automatic welding process performed in accordance with a Welding Procedure Specification (in compliance with Section IX as far as applicable), procedure and performance qualification testing is not required.

In the case where stud welding is used to attach nonload-carrying studs, a production stud weld test, appropriate to the end use application requirements, shall be specified by the Manufacturer or assembler and carried out on a separate test plate or tube as follows:

(a) prior to start of daily operation if used continuously on units of similar construction

(b) prior to the start of application to a given unit when not used continuously

(c) after adjustment or servicing is done on welding equipment

HLW-460.8 Tack Welds. Tack welds used to secure alignment shall either be removed completely when they have served their purpose, or their stopping and starting ends shall be properly prepared by grinding or other suitable means so that they may be satisfactorily incorporated into the final weld. Tack welds, whether removed or left in place, shall be made using a fillet weld or butt weld procedure qualified in accordance with Section IX. Tack welds to be left in place shall be made by welders qualified in accordance with Section IX and shall be examined visually for defects, and if found defective, shall be removed.

It is not necessary that a subcontractor performing such tack welds for the vessel manufacturer be a holder of an ASME Certificate of Authorization. If the tack welds are permanently left in place, the final vessel manufacturer

shall maintain the controls to assure that the necessary welding procedure and performance qualifications are met in order to satisfy Code requirements.

HLW-460.9 Friction Welding.

(a) When joining two parts by the inertia and continuous drive friction welding processes, one of the two parts must be held in a fixed position and the other part rotated. The two faces to be joined must be essentially symmetrical with respect to the axis of rotation. Some of the basic types of applicable joints are solid round to solid round, tube to tube, solid round to tube, solid round to plate, and tube to plate.

(b) The welded joint between two members joined by the inertia and continuous drive friction welding processes shall be a full penetration weld. Visual examination of the as-welded flash roll of each weld shall be made as an in-process check. The weld upset shall meet the specified amount within $\pm 10\%$. The flash shall be removed to sound metal.

ARTICLE 5 TESTS

HLW-500 TESTS TO ESTABLISH MAXIMUM ALLOWABLE WORKING PRESSURE AND PRODUCTION LINE TESTS

HLW-501 General

The required thickness for pressure parts and the maximum allowable working pressure for vessels that are not based upon the formulas of [Article 3](#) shall be established by a proof test. The proof test shall consist of the application of hydrostatic pressure to a full size sample of a vessel. Material in excess of the material thicknesses or of higher strengths than specified for parts of proof test vessel(s) shall be acceptable for production of such parts. The maximum allowable working pressure for a series of vessels may be established by a proof test on one vessel from the series, or two vessels from the series if the ligament spacing differs. Vessels with the smallest and largest ligament spacing on the heads shall be tested.

Vessels in the series shall have

- (a) heads of the same geometry and thickness
- (b) cylindrical shell and tube(s), if used, that differ only by length, and
- (c) openings of the same size and type as those present on the vessel proof tested

Optional openings in the shell may be added in accordance with the provisions of [HLW-308](#).

Optional openings in the heads may be added in accordance with the provisions of [HLW-308](#) if such head openings are located entirely within a circle, the center of which coincides with the center of the head and the diameter of which is equal to 80% of the head diameter.

HLW-502 Proof Test

HLW-502.1 Test Procedure.

(a) Hydrostatic pressure previously applied to the vessel to be proof tested shall not have exceeded $1\frac{1}{2}$ times the anticipated maximum allowable working pressure.

(b) The outer surface of the vessel shall be suitably cleaned. A brittle coating shall be applied. The technique shall be suited to the coating material.

(c) The hydrostatic pressure shall be increased gradually until approximately one-half the anticipated maximum allowable working pressure is reached. Thereafter, the test pressure shall be increased in steps of approximately $\frac{1}{10}$ or less of the anticipated maximum allowable working pressure. The pressure shall be held stationary at the end of each increment for a sufficient time to allow the observations required by the test procedure to be made, and shall be released to zero to permit determination of any permanent strain or displacement after any pressure increment that indicates an increase in strain or displacement over the previous equal pressure increment as evidenced by flaking of the brittle coating, or by the appearance of strain lines. The application of pressure shall be stopped when the intended test pressure has been reached, or at the first sign of yielding.

(d) The yield strength shall be the average of three specimens cut from the part tested after the test is completed. The specimens shall be cut from a location where the stress during the test has not exceeded the yield strength. When excess stock from the same piece of wrought material is available the test specimens may be cut from this excess stock. The specimens shall not be removed by flame cutting or any other method involving sufficient heat to affect the properties of the specimen.

(e) The maximum allowable working pressure P in psi for the water heater tested under this paragraph shall be computed by one of the following formulas:

(1) if the average yield strength is determined in accordance with (d) above,

$$P = 0.5H \frac{Y_s}{Y_a}$$

(2) to eliminate the necessity of cutting tensile specimens and determining the actual yield strength of the material under test, or when the test has been stopped before any yielding, one of the following formulas may be used to determine the maximum allowable working pressure:

(-a) for carbon steel meeting an acceptable Code Specification, with a specified minimum tensile strength of not over 70,000 psi (480 MPa),

(U.S. Customary Units)

$$P = 0.5H \left(\frac{S}{S + 5,000} \right)$$

(SI Units)

$$P = 0.5H \left(\frac{S}{S + 34500} \right)$$

(-b) for any acceptable material listed in Section IV,

$$P = 0.4H$$

where

H = hydrostatic test pressure at which the test was stopped, psi (kPa)

S = specified minimum tensile strength, psi (kPa)

Y_a = actual average yield strength from test specimens, psi (kPa), as outlined in (d)

Y_s = specified minimum yield strength, psi (kPa)

When either of the formulas in (a) and (b) above is used, the material in the pressure part shall have no appreciable cold working or other treatment that would tend to raise the yield strength above the normal.

NOTE: Due to the geometry of parts commonly used in lined water heaters, yielding due to bending often occurs at pressures that are unusually low compared to burst strength. When an analysis of the test indicates yielding occurred in bending, P may be multiplied by 1.5.

HLW-502.2 Test Gages.

(a) An indicating gage shall be connected directly to the water heater vessel. Intermediate pipe and fittings may be used provided there are no intervening valves. If the indicating gage is not readily visible to the operator controlling the pressure applied, an additional indicating gage shall be provided where it will be visible to the operator throughout the duration of the test. For large water heater vessels, it is recommended that a recording gage be used in addition to indicating gages.

(b) Dial-indicating pressure gages used in testing shall be graduated over a range of about double the intended maximum test pressure, but in no case shall the range be less than $1\frac{1}{2}$ nor more than 4 times that pressure. Digital reading pressure gages having a wider range of pressure may be used provided the readings give the same, or greater, degree of accuracy as obtained with dial pressure gages.

(c) All gages shall be calibrated against a standard deadweight tester or a calibrated master gage. Gages shall be recalibrated at any time that there is reason to believe that they are in error.

HLW-503 Testing of Parts

HLW-503.1 Parts of vessels subject to collapse that have not been proof tested in accordance with HLW-502 and for which specified rules are not provided in this Part shall withstand, without excessive deformation, a hydrostatic test of not less than three times the desired maximum allowable working pressure.

HLW-503.2 Cast parts for vessels may have a maximum allowable working pressure established by the bursting test procedure of HG-502.3.

HLW-504 Witnessing, Recording, and Certifying Tests (23)

Tests to establish the maximum allowable working pressure of complete vessels or parts shall be witnessed by the manufacturer's personnel designated to be responsible for the examination. These tests shall also be witnessed and accepted by the Authorized Inspector. These proof tests shall be recorded on Form HLW-8, Manufacturer's Master Data Proof Test Report for Water Heaters or Storage Tanks. The completed form shall be certified by the designated responsible engineering head of the manufacturer. These forms shall be kept on file by the manufacturer as a matter of record.

Requirements for completing Manufacturer's Data Report Forms are shown in Mandatory Appendix 4.

HLW-505 Hydrostatic Test

HLW-505.1 All water heater vessels other than those lined with glass, fluorocarbon polymer, amine epoxy, or polyamine epoxy shall be subjected to a minimum hydrostatic test pressure of $1\frac{1}{2}$ times the maximum allowable working pressure. Water heater vessels lined with glass, fluorocarbon polymer, amine epoxy, or polyamine epoxy shall be subjected to a minimum hydrostatic test pressure at least equal to the maximum allowable working pressure. Water heater vessels that are to be galvanized or cement lined may be pressure tested either before or after galvanizing or cement lining. (23)

HLW-505.2 Part HLW does not specify an upper limit for hydrostatic test pressure. However, if the hydrostatic test pressure is allowed to exceed, either intentionally or accidentally, the value determined as prescribed in HLW-505.1 to the degree that the water heater is subjected to visible permanent distortion, the Inspector shall reserve the right to reject the water heater. If the minimum hydrostatic test pressure for lined water heaters in HLW-505.1 is exceeded by more than 10 psi (70 kPa), the internal surfaces shall be visually inspected for cracks after the test. (23)

HLW-505.3 While under the hydrostatic test pressure an inspection for leakage shall be made of all joints and connections. The visual inspection of joints and connections that are hidden by assembly may be waived during the hydrostatic test provided the following conditions are met:

(a) A suitable pressure test, as agreed upon by the Manufacturer and the Authorized Inspector, is applied to the hidden joints.

(b) The hidden joints are given a visual examination by the Authorized Inspector for workmanship prior to final assembly.

ARTICLE 6

INSPECTION AND MARKING

HLW-600 INSPECTION AND CERTIFICATION

HLW-600.1 Inspection by Authorized Inspector.

Except for cast iron boilers, cast aluminum boilers, or pressure relief valves, the inspection required by this Section shall be by an Inspector employed by an ASME Accredited Authorized Inspection Agency. These inspectors shall have been qualified in accordance with ASME QAI-1.

HLW-600.2 Manufacturer's Responsibility.

(a) The manufacturer who completes any vessel to be marked with the Certification Mark with HLW designator has the responsibility of complying with all requirements of this Part, and through proper certification of assuring that any work done by others also complies with the requirements of this Part.

(b) The manufacturer has the responsibility of providing the Authorized Inspector with all specified information and assurance that the quality control system is in compliance with that outlined in [Nonmandatory Appendix F](#). These responsibilities shall include, but are not limited to, providing or making available for review the following:

(1) a valid Certificate of Authorization for use of the Certification Mark with HLW designator from the ASME Boiler and Pressure Vessel Committee (see [HLW-602](#))

(2) the design calculations per Article 3 or the certified proof test results per Article 5 and associated drawings (see [HLW-300](#) and [HLW-500](#))

(3) identification of materials to show compliance with Articles 2 and 3 and compliance with the provisions of Section IX (see [HLW-200](#) and [HLW-300](#))

(4) evidence of qualification of welding and/or brazing procedures (see [HLW-432](#) and [HLW-450](#))

(5) records of qualifications of each welder, welding operator, or brazer as evidence of compliance with the provisions of Section IX (see [HLW-432](#) and [HLW-450](#))

(6) any Manufacturer's Partial Data Reports when required by [HLW-601.2](#)

(7) evidence of examination of all materials before and during fabrication to make certain it has the required thickness, has no unacceptable imperfections, and is one of the acceptable materials permitted by this Part and that traceability to the material identification has been maintained [see [HLW-201\(c\)](#) and [F-202.4](#)]

(8) the manufacturer shall submit the vessel or other pressure part for inspection at such stages of the work as may be designated by the Inspector

HLW-600.3 Authorized Inspector's Duty.

(a) The Authorized Inspector shall make such inspections as he believes are needed to enable him to certify that the vessels have been constructed in accordance with the rules of this Part. He shall assure himself that the manufacturer is complying with all of the requirements of this Part.

(b) It is the duty of the Inspector to assure himself that the welding procedures employed in construction are qualified under the provisions of Section IX. The manufacturer shall submit evidence to the Inspector that those requirements have been met.

(c) It is the duty of the Inspector to assure himself that all welding is done by welders or welding operators qualified under the provisions of Section IX. The manufacturer shall make available to the Inspector a certified copy of the record of performance qualification tests of each welder and welding operator as evidence that these requirements have been met.

The Inspector has the right at any time to call for and witness the test welding and testing although it is not mandatory that he witness the test welding and the testing unless he so desires.

(d) It is the duty of the Inspector to witness tests conducted to establish the maximum allowable working pressure of water heaters and storage vessels (see [HLW-500](#)).

(e) It is the duty of the Inspector to witness hydrostatic tests (see [HLW-505](#)).

(f) The provisions of [HG-515.4\(b\)](#) apply to the mass production of water heaters and storage tanks.

HLW-601 MANUFACTURER'S DATA AND PARTIAL DATA REPORTS

(23)

HLW-601.1 Manufacturer's Data Report.

(a) Each manufacturer of a vessel to which the Certification Mark with HLW designator is to be applied shall complete a Manufacturer's Data Report Form for each vessel he produces. [Form HLW-6](#) shall

be used. The Manufacturer's Data Report may cover a single vessel or may include the serial numbers in uninterrupted sequence of identical vessels completed, inspected, and marked in a continuous 8-hr period.

A Manufacturer's Master Data Report Form shall be created when a completed vessel or an uninterrupted sequence of identical vessels completed, inspected, and marked in a continuous 8-hr period as defined in [HLW-602](#) has more than one associated Manufacturer's Data Report. The Manufacturer's Master Data Report Form shall be used to summarize all applicable Manufacturer's Data Reports, Partial Data Reports, and Supplementary Sheets for the items comprising the completed vessel or completed sequence of vessels as defined in [HLW-602](#). The "YES" box next to "Manufacturer's Master Data Report" shall be checked to create the Manufacturer's Master Data Report Form. [Form HLW-6](#) shall be used.

(b) The manufacturer shall have the responsibility of furnishing a copy of the completed Manufacturer's Master Data Report or Manufacturer's Data Report at the place of installation to the inspection agency, the purchaser, and the state, municipal, or provincial authority. The manufacturer shall either keep a copy of the Manufacturer's Master Data Report or Manufacturer's Data Report on file for at least 5 yr, or the vessel may be registered and the original Manufacturer's Master Data Report or Manufacturer's Data Report filed with the National Board of Boiler and Pressure Vessel Inspectors, 1055 Crupper Avenue, Columbus, Ohio 43229.

HLW-601.2 Manufacturer's Partial Data Reports.

(a) Manufacturer's Partial Data Reports for those parts of a vessel requiring inspection under this Code, which are furnished by other than the shop of the manufacturer responsible for the completed vessel, shall be completed by the parts manufacturer and shall be forwarded in duplicate to the manufacturer of the completed vessel.

(b) Manufacturer's Partial Data Report Forms, [Form HLW-7](#), shall be completed for all parts that require inspection under this Code that are fabricated by a manufacturer other than the manufacturer of the completed vessel, regardless of whether individual Manufacturer's Data Report Forms are completed for the completed vessels.. These Manufacturer's Partial Data Reports, together with his own inspection, shall be the final Inspector's authority to witness the application of a Certification Mark to the completed vessel.

(c) Manufacturers with multiple locations, each with its own Certificate of Authorization, may transfer parts from one of their locations to another without Manufacturer's Partial Data Reports, provided the Quality Control System describes the method of identification, transfer, and receipt of the parts.

HLW-601.3 Manufacturer's Data Report Supplementary Sheet.

A Manufacturer's Data Report Supplementary Sheet, [Form H-6](#), shall be used to record additional data where space was insufficient on a Manufacturer's Data Report Form. This Manufacturer's Data Report Supplementary Sheet shall be attached to the Manufacturer's Data Report Form where used.

HLW-601.4 Multiple Page Data Reports.

Requirements for completing multiple pages of Manufacturer's Data Report Forms are shown in [Mandatory Appendix 4](#).

HLW-602 MARKING OF WATER HEATERS AND STORAGE TANKS (23)

HLW-602.1 Marking Requirements for Vessels.

(a) All vessels to which the Certification Mark is to be applied shall be built according to the rules of this Part by a manufacturer who is in possession of a Certification Mark and a valid Certificate of Authorization per procedure of [HG-540](#). Each vessel shall be marked with the Certification Mark with the HLW designator shown in [Figure HLW-602.1](#). The marking shall include the following data, as shown in [Figure HLW-602.2](#):

(1) the manufacturer's name, preceded by the words "Certified by."

(2) maximum allowable working pressure.

(3) maximum water temperature.

(4) maximum allowable input in Btu/hr; electric heaters may use kW or Btu/hr (expressed at the rate of 3,500 Btu/hr/kW) or both. In lieu of the input markings storage tanks shall be marked "Storage Only."

(5) manufacturer's serial number (this may be a serial number or a combination model and serial number).

(6) year built (the year built may be incorporated into the serial number as a prefix containing the last two digits of the year).

(b) When the Certification Mark and marking required in (a) is applied directly to the water heater vessel, it shall be marked with letters and figures at least $\frac{5}{16}$ in. (8 mm) high.

(c) Nameplates at least $\frac{3}{64}$ in. (1.2 mm) thick bearing the marking required in (a) may be used in lieu of marking this information directly on the water heater vessel if the nameplates are permanently attached to the water heater vessel. In this case, the required data on the nameplate shall be in characters not less than $\frac{5}{16}$ in. (8 mm) high [except as permitted in (e)].

(d) When a nameplate is used, the information listed in (a), including the Certification Mark, shall be applied by stamping, etching, engraving, dot peening, laser annealing, or another process that leaves a permanent, legible mark. No coating that obscures the marking shall be allowed. For

Figure HLW-602.1
Official Symbol to Denote The American Society of
Mechanical Engineers' Standard

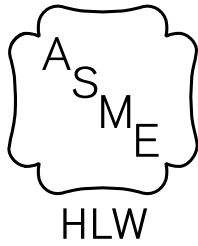

processes other than direct stamping, the following additional requirements apply:

(1) The process controls shall be described in the Quality Control System and shall be acceptable to the Authorized Inspector.

(2) For any process that removes or displaces material, controls shall be established so that the characters shall be at least 0.004 in. (0.10 mm) deep.

(3) Processes that do not remove or displace material (e.g., etching, laser annealing) shall be used only on clean, uncoated, and unpainted surfaces.

(4) Laser annealing shall be allowed only on stainless steel and aluminum.

(e) When there is insufficient space for the nameplate required in (c), smaller letter dimensions may be used, provided

(1) marking shall be as required in (a)

(2) character size shall be no smaller than $\frac{5}{32}$ in. (4 mm), and

(3) the information, including the Certification Mark, shall be marked as described in (d)

(f) If the required marking is to be covered by insulation, jacket, or other form of casing, one of the following shall be provided:

(1) an opening with a removal cover for viewing the marking or stamping.

(2) a nameplate, located in a conspicuous place on the jacket, duplicating the required Certification Mark and data. This plate shall be at least 3 in. × 4 in. (75 mm × 100 mm) in size marked with letters and numerals at least $\frac{1}{8}$ in. (3 mm) high and of either metallic material attached by mechanical means or of any material attached by an adhesive system meeting the requirements of [Mandatory Appendix 3](#).

HLW-602.2 Marking a Proof-Tested Vessel. A completed vessel or one tested prior to lining may have the required Certification Mark and marking applied, provided

(a) the proof test was stopped before any visible yielding

(b) all welding was qualified as required by [HLW-451](#)

(c) the MAWP is calculated by the method of [HLW-502.1\(d\)\(2\)](#)

(d) the interior of a lined vessel must be inspected to verify that it was not damaged, and

(e) the completed vessel is subjected to the hydrostatic test provisions of [HLW-505](#)

HLW-602.3 Marking of Parts and Accessories

(a) Parts for which a Manufacturer's Partial Data Report, [Form HLW-7](#), is required by [HLW-601.2](#) shall be marked with the following:

(1) the official Certification Mark shown in [Figure HLW-602.1](#) with the HLW designator above the word "Part." The HLW designator and the word "Part" may be replaced with the PRT IV designator.

(2) the part manufacturer's name.

(3) the part manufacturer's serial number.

(b) In lieu of marking the information described in (a) directly on the vessel, a nameplate as described in [HLW-602.1](#) may be used.

(c) Small parts [5-in. (125-mm) O.D. and under] may be marked with an identification acceptable to the Inspector (e.g., a bar code, etching, or paint stencil) and traceable to the Manufacturer's Partial Data Report in lieu of the marking described in (a). Such marking shall be of a type that will remain visible until the part is installed. The Certification Mark is not required.

(d) A nameplate furnished with the Certification Mark on parts may be removed during the completion of the vessel if all of the following conditions are satisfied:

Figure HLW-602.2
Form of Marking on Completed Water Heaters

 HLW	Certified by

	(Name of Manufacturer)
	Max. Allowable W. P. [Note (1)] _____
	Max. Water Temp. [Note (2)] _____
	Max. Allowable Input [Note (3)] _____
	Manufacturer's Serial No. _____
	Year built _____

GENERAL NOTE: Acceptable abbreviations of any of the marked wording may be used.

NOTES:

(1) May be listed as psi or kPa.

(2) May be listed as °F or °C.

(3) Kilowatt (kW) power input for electric boilers.

(1) The nameplate interferes with further fabrication or service.

(2) The Manufacturer of the completed vessel has agreement from the Authorized Inspector to remove the nameplate.

(3) The removal of the nameplate shall be noted in the Remarks section of the Manufacturer's Data Report.

(4) The removed nameplate shall be destroyed.

ARTICLE 7 CONTROLS

HLW-700 CONTROLS

HLW-701 Temperature Control

HLW-701.1 Each individual automatically fired water heater shall have a high temperature limit control that is separate from the operating control used for normal water heater operation. The temperature range of the high temperature limit control. The high temperature limit control shall cut off the fuel supply at or below the designed maximum water temperature as indicated on the water heater's Manufacturer's Data Report. This control shall be constructed to prevent a temperature setting above the maximum.

(a) On gas-fired water heaters, the high temperature limit control when actuated shall shut off the fuel supply with a shutoff means other than the operating control valve. Separate valves may have a common body.

(b) On electrically heated water heaters, the high temperature limit control when actuated shall cut off all power to the operating controls.

(c) On oil-fired water heaters, the high temperature limit control when actuated shall cut off all current flow to the burner mechanism.

(d) On indirect water heating systems, the high temperature limit control when activated shall cut off the source of heat.

HLW-702 Limit Controls

Limit controls used with electric circuits should break the hot or line sides of the control circuit.

HLW-703 Controls and Heat Generating Apparatus

(a) All water heaters should be equipped with suitable primary (flame safeguard) safety controls, safety limit switches, and burners, or electric elements as required by a nationally recognized standard.³⁰

(b) The symbol of the certifying organization¹⁴ that has investigated such equipment as having complied with a nationally recognized standard shall be affixed to the equipment and shall be considered as evidence that the controls and heat generating apparatus were manufactured in accordance with that standard.

HLW-704 Electrical Wiring

HLW-704.1 Electrical Code Compliance. All field wiring for controls, heat generating apparatus, and other appurtenances necessary for the operation of the water heater should be installed in accordance with the provisions of the National Electrical Code and/or should comply with the applicable local electrical codes. All water heaters supplied with factory mounted and wired controls, heat generating apparatus, and other appurtenances necessary for the operation of the water heaters should be installed in accordance with the provisions of the nationally recognized standards such as those of [HLW-703](#).³⁰

ARTICLE 8

INSTALLATION REQUIREMENTS

HLW-800 PRESSURE RELIEF VALVES

(23) **HLW-800.1 Pressure Relief Valve Requirements for Water Heaters.**

(a) Each water heater shall have at least one temperature and pressure relief valve or at least one pressure relief valve. Pressure relief valves shall be of the spring-loaded safety relief valve type. The valve or valves shall be marked either with the Certification Mark and HV Designator in accordance with Section XIII or with the Certification Mark and V Designator in accordance with Section I.

(b) The pressure setting shall be less than or equal to the maximum allowable working pressure (MAWP) of the water heater. However, if any of the other components in the hot water supply system (e.g., valves, pumps, expansion or storage tanks, or piping) have a lesser working pressure rating than the water heater, the pressure setting for the pressure relief valve or valves shall be based on the component with the lowest MAWP rating. If more than one pressure relief valve is used, the additional valve or valves may be set within a range not to exceed 10% over the set pressure of the first valve. The set pressure tolerances shall not exceed 3 psi (20 kPa) for pressures up to and including 60 psig (400 kPa) and $\pm 5\%$ for set pressures above 60 psig (400 kPa).

(c) The required relieving capacity in Btu/hr of the pressure relief valve shall not be less than the maximum allowable input. Alternatively, if the rated burner input capacity of the water heater is visibly marked on the water heater casing, the rated burner input capacity may be used as a basis for sizing the pressure relief valve. The relieving capacity for electric water heaters shall be 3,500 Btu/hr (1.0 kW) per kilowatt of input. In every case, the following requirements shall be met. Pressure relief valve capacity for each water heater shall be such that, with the fuel-burning equipment installed and operated at maximum capacity, the pressure cannot rise more than 10% of MAWP.

(d) If operating conditions are changed or additional heater heating surface is installed, the pressure relief valve capacity shall be increased, if necessary, to meet the new conditions and shall be in accordance with the above provisions. In no case shall the increased input capacity exceed the maximum allowable input capacity. The

additional valves required to account for changed conditions may be installed on the outlet piping provided there is no intervening valve.

HLW-801 MOUNTING PRESSURE RELIEF VALVES

HLW-801.1 Installation. Pressure relief valves shall be installed by either the installer or the manufacturer before a water heater is placed in operation.

HLW-801.2 Permissible Mountings. Pressure relief valves shall be connected to the top of water heaters or directly to a tapped or flanged opening in the water heater, to a fitting connected to the water heater by a short nipple, to a Y-base, or to a valveless header connecting water outlets on the same heater. Pressure relief valves shall be installed with their spindles upright and vertical with no horizontal connecting pipe, except that, when the pressure relief valve is mounted directly on the water heater vessel with no more than 4 in. (100 mm) maximum interconnecting piping, the valve may be installed in the horizontal position with the outlet pointed down. The center line of the pressure relief valve connection shall be no lower than 4 in. (100 mm) from the top of the shell. No piping or fitting used to mount the pressure relief valve shall be of a nominal pipe size less than that of the valve inlet.

HLW-801.3 Requirements for Common Connection for Two or More Valves. (23)

(a) When a water heater is fitted with two or more pressure relief valves on one connection, this connection shall have a cross-sectional area not less than the combined areas of inlet connections of all the pressure relief valves with which it connects.

(b) A Y-base shall not be used with temperature and pressure relief valves.

(c) When a Y-base is used, the inlet area shall be not less than the combined outlet areas. When the size of the water heater requires a pressure relief valve larger than 4½ in. (114 mm) diameter, two or more valves having the required combined capacity shall be used. When two or more valves are used on a water heater, they may be single, directly attached, or mounted on a Y-base.

HLW-801.4 Threaded Connections. A threaded connection may be used for attaching a valve.

HLW-801.5 Prohibited Mountings. Pressure relief valves shall not be connected to an internal pipe in the water heater or a cold water feed line connected to the water heater.

HLW-801.6 Use of Shutoff Valves Prohibited. No shutoff of any description shall be placed between the pressure relief valve and the water heater, or on discharge pipes between such valves and the atmosphere.

(23) **HLW-801.7 Pressure Relief Valve Discharge Piping.**

(a) When a discharge pipe is used, its internal cross-sectional area shall be not less than the full area of the valve outlet or of the total of the valve outlets discharging thereinto, and shall be as short and straight as possible and so arranged as to avoid undue stress on the valve or valves. When an elbow is placed on a pressure relief discharge pipe, it shall be located close to the valve outlet.

(b) The discharge from pressure relief valves shall be so arranged that there will be no danger of scalding attendants. When the pressure relief valve discharge is piped away from the water heater to the point of discharge, there shall be provisions for properly draining the piping and valve body. The size and arrangement of discharge piping shall be such that it will not reduce the relieving capacity of the pressure relief valves below that required to protect the water heater.

HLW-805 WATER SUPPLY

HLW-805.1 Connections. Water supply shall be introduced into a water heater through an independent water supply connection. Feedwater shall not be introduced through openings or connections provided for cleaning, pressure relief valves, drain, pressure gage, or temperature gage.

HLW-805.2 Pressure. If the water supply pressure to a water heater exceeds 75% of the set pressure of the pressure relief valve, a pressure reducing valve is required.

HLW-805.3 Stop Valves. Stop valves should be placed in the supply and discharge pipe connections of a water heater installation to permit draining the water heater without emptying the system.

HLW-809 PROVISIONS FOR THERMAL EXPANSION IN HOT WATER SYSTEMS

HLW-809.1 Expansion Tank. If a system is equipped with a check valve or pressure reducing valve in the cold water inlet line, consideration should be given to the installation of an airtight expansion tank or other suitable air cushion. Otherwise, due to the thermal expansion of the water, the pressure relief valve may open periodically. If an expansion tank is provided, it shall be constructed in accordance with Section VIII, Division 1 or Section X. See [Figure HLW-809.1](#) for a typical acceptable installation (and [Table HLW-809.1](#) for expansion tank capacities). Except for prepressurized diaphragm type tanks, which should be installed on the cold water side, provisions shall be made for draining the tank without emptying the system.

HLW-809.2 Piping. Provisions shall be made for the expansion and contraction of hot water mains connected to water heaters by providing substantial anchorage at suitable points and by providing swing joints when water heaters are installed in batteries, so that there will be no undue strain transmitted to the water heaters. See [Figures HLW-809.1](#) and [HLW-809.2](#) for typical schematic arrangements of piping incorporating strain absorbing joints.

HLW-810 BOTTOM DRAIN VALVE

(23)

(a) Each water heater shall have a bottom drain pipe connection at the lowest practicable point on the water heater. A valve or cock shall be fitted to the bottom drain pipe connection or to the lowest point on piping connected to the water heater at the bottom drain pipe connection. The minimum size bottom drain valve shall be NPS $\frac{3}{4}$ (DN 20).

(b) Any discharge piping connected to the bottom drain connection shall be full size to the point of discharge.

(c) The bottom drain valve of a potable water heater may be installed in a storage vessel piped directly to the water heater, provided the following requirements are met:

(1) The entire assembly, comprising a single water heater and a single storage tank, including all controls, safety devices, piping, and fittings, has a common frame or enclosure and shall be listed and labeled for use by a nationally recognized testing agency.

(2) The water heater shall be installed directly on top of the storage vessel.

(3) The drain valve shall be installed at the lowest practical point on the storage vessel.

(4) The minimum size of the bottom drain valve shall be NPS $\frac{3}{4}$ (DN 20).

(5) The drain on the storage vessel shall meet the requirements of (b).

HLW-820 THERMOMETER

Each installed water heater shall have a thermometer so located and connected that it shall be easily readable. The thermometer shall be so located that it shall at all times indicate the temperature of the water in the water heater at or near the outlet.

**Figure HLW-809.1
A Typical Acceptable Piping Installation for Storage Water Heaters in Battery**

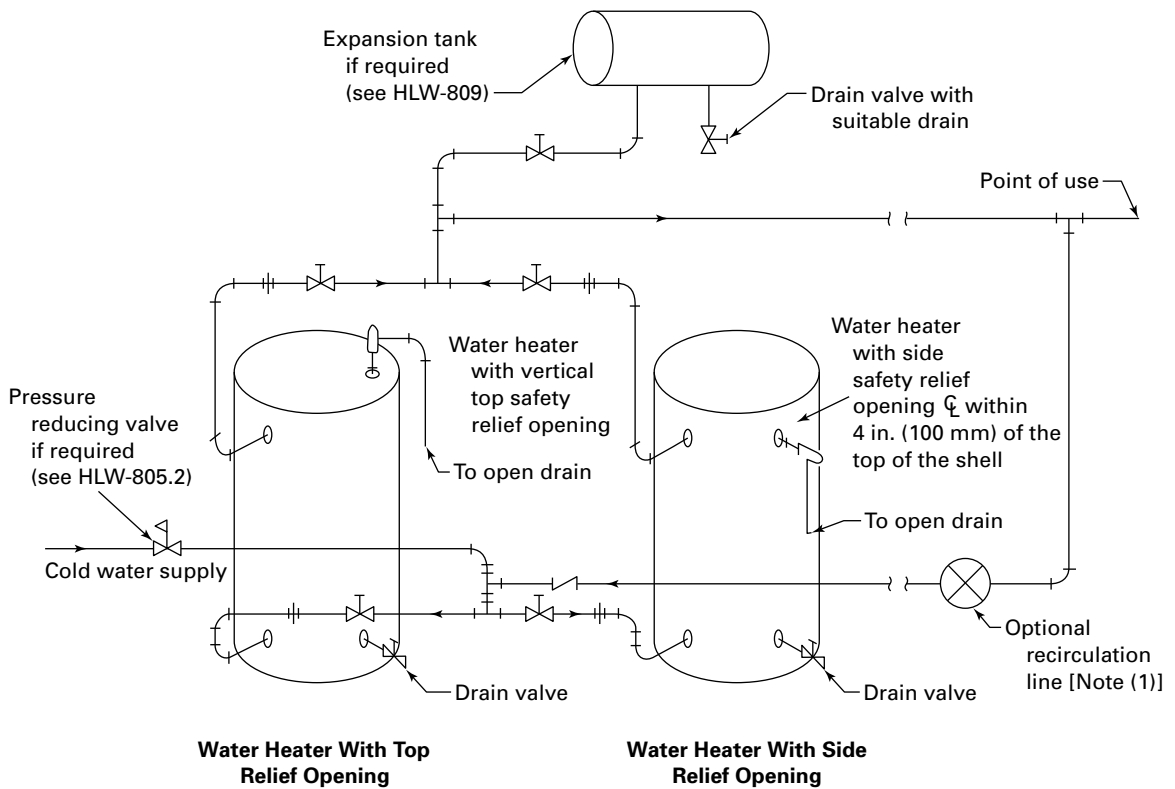

GENERAL NOTE: Thermometer requirements are in HLW-820.

NOTE: (1) Recirculation system may be gravity or pump actuated.

**Table HLW-809.1
Expansion Tank Capacities for a Water Heater**

System Volume, gal (m ³)	Tank Capacities, gal (m ³)	
	Prepressurized Diaphragm Type	Nonprepressurized Type
50 (0.19)	1 (0.004)	3 (0.011)
100 (0.38)	2 (0.006)	6 (0.023)
200 (0.76)	3 (0.011)	12 (0.045)
300 (1.14)	4 (0.015)	18 (0.068)
400 (1.51)	5 (0.019)	24 (0.091)
500 (1.89)	6 (0.023)	30 (0.114)
1,000 (3.79)	12 (0.045)	60 (0.227)
2,000 (7.57)	24 (0.091)	120 (0.454)

GENERAL NOTES:

- (a) Capacities in this Table are given as a guide to reduce or eliminate pressure relief valve weeping under conditions of partial water system demands or occasional water draw during recovery.
- (b) System volume includes water heater capacity plus all piping capacity for a recirculation system or water heater capacity only for a nonrecirculation system.
- (c) The capacities are based upon a water temperature rise from 40°F to 180°F (4°C to 82°C), 60 psi (400 kPa) fill pressure, maximum operating pressure of 125 psi (850 kPa), 20% water recovery, and an acceptance factor of 0.465 for prepressurized types and 0.09156 for nonprepressurized types. A procedure for estimating system volume and for determining expansion tank sizes for other design conditions may be found in Chapter 12 of the 1996 HVAC Systems and Equipment Volume of the ASHRAE Handbook.

**Figure HLW-809.2
A Typical Acceptable Piping Installation for Flow Through Water Heater With Provisions for Piping Expansion**

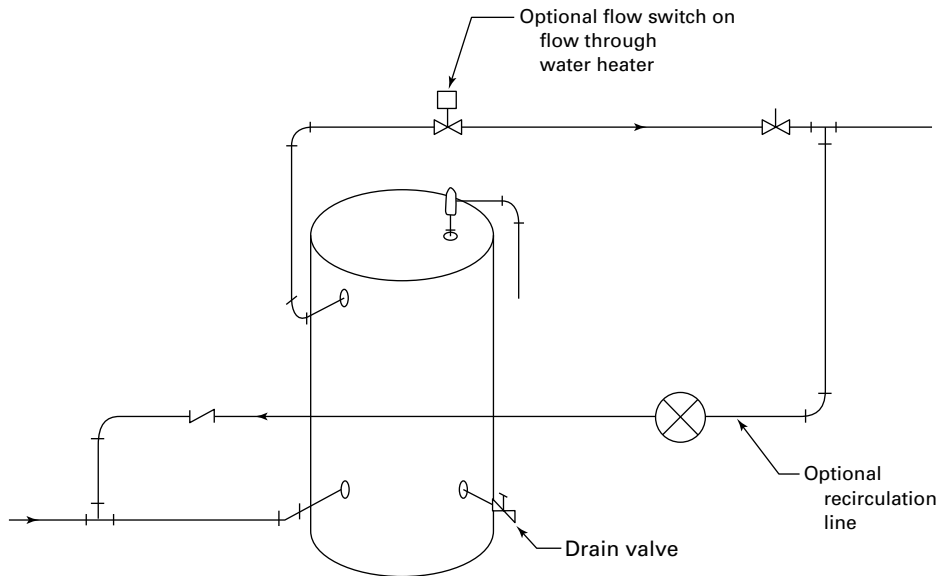

GENERAL NOTE: Thermometer requirements are in [HLW-820](#).

ARTICLE 9

MODULAR WATER HEATER REQUIREMENTS

(23)

HLW-900 GENERAL

The requirements of this Article are applicable to modular water heaters and parts thereof and shall be used in conjunction with the general requirements in [Part HLW](#) that are not replaced by the special modular water heater requirements in this Section.

HLW-901 MARKING

Modular water heaters shall be marked and certified using one of the following methods:

(a) Individual water heaters are marked and certified as complete water heaters as follows:

(1) Individual water heaters shall have their own markings applied per the requirements of [HLW-602](#). Each individual water heater shall have its own Manufacturer's Master Data Report or Manufacturer's Data Report, per the requirements of [HLW-601.1\(a\)](#). [Form HLW-6](#) shall be used.

(2) The common supply and return headers are exempt from Section IV requirements.

(3) The Manufacturer's Modular Master Data Report shall summarize specific information for each water heater, including the applicable Manufacturer's Data Reports. [Form H-1](#) shall be used.

(b) Multiple individual unmarked modules are combined together and certified as a complete modular water heater as follows:

(1) The assembled modular water heater shall have a single nameplate per the requirements of [HLW-602](#) and a Manufacturer's Modular Master Data Report.

(2) Individual modules shall bear the manufacturers name and be permanently identified using one of the methods in [HLW-602.3](#) in a manner traceable to the assembled modular water heater nameplate and Manufacturer's Master Data Report or Manufacturer's Data Report per the requirements of [HLW-601.1\(a\)](#). [Form HLW-6](#) shall be used.

(3) The supply and return headers shall be constructed in accordance with Section IV and recorded on a Manufacturer's Data Report. [Form HLW-6](#) shall be used.

(4) The aggregate maximum input in Btu/hr (kW) shall be marked on the nameplate.

(5) The Manufacturer's Modular Master Data Report shall summarize specific information for each module, including the applicable Manufacturer's Data Reports. [Form H-1](#) shall be used.

HLW-902 INSTRUMENTS, FITTINGS, AND CONTROLS

(a) Each individual water heater of a modular hot water heater shall be equipped with

(1) a thermometer (see [HLW-820](#))

(2) an operating control used for normal water heater operation (see [HLW-701](#))

(b) The assembled modular water heater shall also be equipped with a high-temperature limit control that shall cut off the fuel supply at or below the maximum water temperature marked on the water heaters (see [HLW-602](#) and [HLW-701](#)).

(c) When the assembled modular water heater is certified as a single water heater in accordance with [HLW-901\(b\)](#), the water heater assembly shall be equipped with

(1) a thermometer, which may be located in the supply (i.e., distribution) header (see [HLW-820](#))

(2) an operating control used for normal water heater operation (see [HLW-701](#))

(3) a high-temperature limit control that shall cut off the fuel supply at or below the maximum water temperature marked on the water heater (see [HLW-602](#) and [HLW-701](#))

HLW-903 INSTALLATION REQUIREMENTS

(a) The assembled modular water heater shall be installed without stop valves between modules and shall be provided with a single set of stop valves on the common supply (i.e., distribution) and return or makeup water headers in accordance with [HLW-805.3](#).

(b) The stop valves required by (a) may be eliminated when the modular water heater can be drained without draining the system. Means to allow draining the modular water heater without emptying the system may include locating the modular water heater above the system or isolating the modular water heater from the system by equipment.

(c) Flow control valves and circulating pumps may be located in the makeup water lines of the individual modules.

(d) Modular water heaters that are installed side by side, front to back, or by stacking in accordance with the Manufacturer's recommendations shall have their nameplate marking located to provide access for inspection in the assembled position.

(e) Each individual water heater of a modular water heater shall be equipped with

(1) one or more pressure relief valves (see [HLW-800](#) and [HLW-801](#))

(2) a bottom drain valve, which may be replaced by one or more bottom drain valves located on the return header or piping connected to the water heater drain pipe connection provided the arrangement of the modules is such as to allow the drain valve or valves to drain the entire water heater [see [HLW-810\(a\)](#) and [HLW-810\(b\)](#)]

(f) The assembled modular water heater shall also be equipped with

(1) a makeup water connection (see [HLW-805](#))

(2) provision for thermal expansion, if required (see [HLW-809](#))

(g) When the assembled modular water heater is certified as a single water heater in accordance with [HLW-901\(b\)](#), it shall be equipped with

(1) one or more pressure relief valves, which may be located on the supply header (see [HLW-800](#) and [HLW-801](#))

(2) one or more bottom drain valves located on the return header or piping connected to the water heater drain pipe connection provided the arrangement of the modules is such as to allow the drain valve or valves to drain the entire water heater [see [HLW-810\(a\)](#) and [HLW-810\(b\)](#)]

(3) a makeup water connection (see [HLW-805](#))

(4) provision for thermal expansion, if required (see [HLW-809](#))

MANDATORY APPENDIX 2

CODES, STANDARDS, AND SPECIFICATIONS REFERENCED IN TEXT

2-100 REFERENCE STANDARDS

Specific editions of standards incorporated in this Code are shown in [Table 2-100](#). It is not practical to refer to a specific edition of each standard throughout the Code text, so edition references are centralized here. [Table 2-100](#) will be revised at intervals and reissued as needed.

Listed below are the names, acronyms, and addresses of specific organizations referred to in this Code.

Publisher: American National Standards Institute (ANSI),
25 West 43rd Street, New York, NY 10036 (212) 642-4900 (<http://www.ansi.org>)

Publisher: American Society for Testing and Materials (ASTM International), 100 Barr Harbor Drive, P.O. Box C700, West Conshohocken, PA 19428-2959 (877) 909-2726 (<http://www.astm.org>)

Publisher: American Society of Heating, Refrigerating and Air-Conditioning Engineers, Inc. (ASHRAE), 180 Technology Parkway NW, Peachtree Corners, GA 30092 (800) 527-4734, (404) 636-8400 (<http://www.ashrae.org>)

Publisher: Canadian Standards Association (CSA), 5060 Spectrum Way, Mississauga, Ontario L4W 5N6, Canada (416) 747-4000 (404) 636-8400 (<http://www.csa.ca>)

Publisher: German Institute for Standardization (DIN),
DIN Deutsches Institut für Normung e. V., Am DIN-Platz, Burggrafenstrasse 6, 10787 Berlin, Germany +49 30 2601-0 (<http://www.din.de>)

Publisher: National Fire Protection Association (NFPA), 1 Batterymarch Park, Quincy, MA 02169 (617) 770-3000 (404) 636-8400 (<http://www.nfpa.org>)

Publisher: National Sanitation Foundation (NSF International), 789 North Dixboro Road, Ann Arbor, MI 48113 (800) 673-6275 (734) 769-8010 (<http://www.nsf.org>)

Publisher: Underwriters Laboratories, Inc. (UL), 333 Pfingsten Road, Northbrook, IL 60062-2096 (847) 272-8800 (734) 769-8010 (<http://www.ul.com>)

2-200 ORGANIZATIONS

For names, acronyms, and addresses of specific organizations referred to in this Code, see [Nonmandatory Appendix H](#).

Table 2-100
Codes, Standards, and Specifications Referenced in Text

(23)

Document Designator	Document Title
ASME Standards	
B16.1	Gray Iron Pipe Flanges and Flanged Fittings: Classes 25, 125, and 250
B16.3	Malleable Iron Threaded Fittings: Classes 150 and 300
B16.4	Gray Iron Threaded Fittings: Classes 125 and 150
B16.5	Pipe Flanges and Flanged Fittings: NPS ½ Through NPS 24 Metric/Inch Standard
B16.9	Factory-Made Wrought Butt-welding Fittings
B16.11	Forged Fittings, Socket-Welding and Threaded
B16.15	Cast Copper Alloy Threaded Fittings: Classes 125 and 250
B16.20	Metallic Gaskets for Pipe Flanges
B16.21	Nonmetallic Flat Gaskets for Pipe Flanges
B16.24	Cast Copper Alloy Pipe Flanges, Flanged Fittings, and Valves:: Classes 150, 300, 600, 900, 1500, and 2500
B16.42	Ductile Iron Pipe Flanges and Flanged Fittings: Classes 150 and 300
B36.10M	Welded and Seamless Wrought Steel Pipe
B36.19M	Stainless Steel Pipe
CA-1	Conformity Assessment Requirements
QAI-1	Qualifications for Authorized Inspection
National Sanitation Foundation (NSF) International Standard	
NSF/ANSI 14	Plastic Piping System Components and Related Materials
Underwriters Laboratories Standards for Safety	
UL 353	Standard for Limit Controls
UL 969	Standard for Marking and Labeling Systems
American Society for Testing and Materials (ASTM)	
ASTM A126	Standard Specification for Gray Iron Castings for Valves, Flanges, and Pipe Fittings
ASTM B6	Standard Specification for Zinc
ASTM B733	Standard Specification for Autocatalytic (Electroless) Nickel-Phosphorus Coatings on Metal
ASTM D570	Standard Test Method for Water Absorption of Plastics
ASTM E8/E8M	Standard Test Methods for Tension Testing of Metallic Materials
ASTM E9	Standard Test Methods of Compression Testing of Metallic Materials at Room Temperature
Deutsches Institut für Normung e. V. (DIN)	
DIN 443	Sealing Push-in Caps

GENERAL NOTE: Unless otherwise noted, the latest edition shall apply.

MANDATORY APPENDIX 3

ADHESIVE ATTACHMENT OF NAMEPLATES TO CASING

3-100 SCOPE

This Appendix covers the qualification of procedures for the adhesive attachment of nameplates. The use of adhesive systems for the attachment of nameplates shall be permitted only under the following conditions:

(a) The adhesive used is a pressure-sensitive acrylic adhesive that has been preapplied by the nameplate manufacturer.

(b) The nameplate material has a minimum thickness of 0.002 in. (0.05 mm).

(c) The adhesive is protected with a moisture-stable release liner.

(d) The nameplate is applied to a clean surface.

(e) The nameplate application procedure is qualified as outlined in 3-101.

(f) The preapplied adhesive is used within 2 yr of its application.

3-101 NAMEPLATE APPLICATION PROCEDURE QUALIFICATION

(a) Each nameplate manufacturer's construction shall be qualified in accordance with ANSI/UL 969, Marking and Labeling Systems, for a surface temperature rating greater than that achieved on the surface of the casing in the area

where the nameplate is applied during operation. The exposure conditions shall be for high humidity or occasional exposure to water. In addition if the boiler or water heater is designed and marked for outdoor installation, indoor-outdoor qualification shall be obtained with a cold box temperature of -40°F (-40°C).

(b) Each lot or package of nameplates shall be marked with the adhesive application date.

(c) The manufacturer's quality control system shall define that written procedures, acceptable to the Authorized Inspector (or ASME Designee for cast iron boilers), for the application of adhesive backed nameplates shall be prepared and qualified. The application procedure qualification shall include the following essential variables:

(1) each nameplate manufacturer's material and construction, including thickness range, UL File No., and rated substrate temperature(s) and finish

(2) the maximum temperature achieved on the surface of the casing in the area at which the nameplate is applied

(3) cleaning requirements for the surface to which the nameplate is applied

(4) application temperature range and pressure technique

MANDATORY APPENDIX 4

GUIDE TO MANUFACTURER'S DATA REPORT FORMS

(23)

4-100 INTRODUCTION

(a) The following pages are a guide for completing the Manufacturer's Data Report Forms. The explanations included in the guide are keyed to the Manufacturer's Data Report Forms in the following manner:

(1) Circled numbers on each of the Manufacturer's Data Report Forms refer to the items listed on the guide (Table 4-1). The parenthesized numbers on the guide (Table 4-1) correspond to the circled numbers on the Manufacturer's Data Report Forms.

(2) Numbers without circles appearing in the guide identify specific lines on the Manufacturer's Data Report Forms.

(b) Any quantity to which units apply shall be entered on the Manufacturer's Data Report Forms with the chosen units. Manufacturer's Data Report Forms appearing in this section may be obtained from The American Society of Mechanical Engineers (ASME), Two Park Avenue, New York, NY 10016-5990 (www.asme.org).

4-200 MANUFACTURER'S DATA REPORT FORMS

(a) Manufacturer's Data Report Forms may be preprinted or computer-generated. Manufacturer's Data Report Forms shall be identical in size, arrangement, and content as purchased Manufacturer's Data Report Forms or to those shown in this Appendix, except that additional lines may be added as necessary.

(b) When using Manufacturer's Data Report Forms that result in multiple pages, each page shall be marked to be traceable to the first page of the form as follows:

(1) For Forms H-1, H-2, H-3, and HLW-6, each page shall show, at the top of the page, as a minimum, the Manufacturer's name and serial number and National Board number as shown on the first page.

(2) For Forms H-4 and HLW-7, each page shall show, at the top of the page, as a minimum, the Manufacturer's name and Manufacturer's Data Report Form ID number as shown on the first page.

(3) For Forms H-5 and H-5A, each page shall show, at the top of the page, as a minimum, the Manufacturer's name and Boiler type or model number as shown on the first page.

(c) Additionally on all Manufacturer's Data Report Forms, each sheet shall contain the page number of that page and the total number of pages that comprise the complete form.

(d) These requirements do not apply to the Manufacturer's Data Report Supplementary Sheet (Form H-6) since that form is intended to be a single-page form attached to a Manufacturer's Data Report Form (see HG-520.3 or HLW-601.3).

(e) These requirements do not apply to Form HLW-8 since that form is intended to be a single-page form.

4-300 CERTIFICATE OF CONFORMANCE FORMS

(a) Certificate of Conformance Forms are intended to be single-page forms. This includes Forms HC-1, HC-2, HA-1, and HA-2.

(b) Certificate of Conformance Forms may be preprinted or computer-generated. Certificate of Conformance Forms shall be identical in size, arrangement, and content to purchased Certificate of Conformance Forms or to those shown in this Appendix.

Table 4-1
Guide for the Preparation of Section IV Manufacturer’s Data Report Forms

(23)

Applies to Form										Reference to Circled Numbers in the Forms	Instructions
H-1	H-2	H-3	H-4	H-5	H-5A	H-6	HLW-6	HLW-7	HLW-8		
X	X	X	X	X	X	X	X	X	X	(1)	Name and address of manufacturer (i.e., maker of all components not covered by Partial Data Reports).
X	X	X	X	X	X	X	...	(2)	Name and address of purchaser and/or owner.
X	X	X	X	X	X	(3)	Name and address of location where unit is to be installed. If not known, so indicate (e.g., “not known — built for stock”).
X	X	X	...	X	X	X	X	(4)	Show type or model of unit documented by this Manufacturer’s Data Report.
X	X	X	X	X	X	X	...	(5)	Identification of unit by applicable numbers. If intended for installation in Canada, indicate the Canadian design registration number and drawing number.
X	X	X	X	X	X	X	...	(6)	Year in which fabrication was completed in shop.
X	X	X	X	X	X	...	(7)	Date (year) of Section IV edition to which boiler or part was designed.
X	X	X	X	X	X	...	(8)	Issue date of most recent addenda to Section IV to which boiler or part was designed (e.g., “December 1997”).
X	X	X	X	X	(9)	Code Case number, if applicable.
...	X	(10)	Show quantity and inside dimensions. If more than two shells or drums are used, enter data in line 14.
...	X	X	X	X	X	X	(11)	Show the complete ASME material specification number and grade as listed in the appropriate stress allowance table in Section IV (e.g., “SA- 285-B”) Exception: A specification number for a material not identical to an ASME Specification may be shown only if such material has been approved for Section IV construction by an ASME interpretation case ruling and provided the applicable case number is also shown.
...	X	X	X	...	(12)	Indicate type of joint(s).
...	X	X	X	...	(13)	Show joint efficiency for welded joints.
...	X	(14)	Show number of furnaces in boiler.
...	X	(15)	For cylindrical furnaces of the Adamson, ring-reinforced, and combined types, show total length only.
...	X	(16)	For stayed (firebox) type furnace, complete line 12 also.
...	X	(17)	If threaded, show diameter at root of thread.
...	X	(18)	Minimum cross-sectional area after deducting for telltale hole.
...	X	(19)	Maximum allowable working pressure for the stayed area calculated according to the rules contained in Part HG of Section IV.
...	X	(20)	Type of stay or brace (e.g., diagonal, gusset, girder, through, etc.).
...	X	(21)	Minimum cross-sectional area of the stay or brace multiplied by the number of stays or braces supporting the area under consideration.
...	X	(22)	See applicable paragraphs and figures in Part HG of Section IV.
...	X	(23)	List parts not covered elsewhere on the Manufacturer’s Data Report. If insufficient space, attach a supplementary sheet.
...	X	(24)	Tabulate data for parts listed on line 14.
...	X	X	X	X	(25)	Show data for main and auxiliary inlets and outlets, nozzles, inspection openings, pressure relief valve openings, drains, and blowoffs. This does not apply to small openings for water column, controls, vents, etc.
X	X	X	X	(26)	Maximum allowable working pressure.
X	X	(27)	Show Section IV paragraph that applies to the weakest part of the unit as established by calculation or deformation test.
...	X	(28)	Boiler heating surface calculated in accordance with HG-403A of Section IV.

**Table 4-1
Guide for the Preparation of Section IV Manufacturer's Data Report Forms (Cont'd)**

Applies to Form										Reference to Circled Numbers in the Forms	Instructions
H-1	H-2	H-3	H-4	H-5	H-5A	H-6	HLW-6	HLW-7	HLW-8		
X	X	(29)	Hydrostatic or pneumatic pressure applied in accordance with HG-510 or HG-511 and witnessed by the Authorized Inspector.
...	X	X	X	X	...	(30)	To be completed when one or more components comprising the unit are furnished by others and certified by the applicable Manufacturer's Partial Data Report(s).
X	X	X	X	X	X	X	X	X	X	(31)	The manufacturer's ASME Certificate of Authorization number and date of expiration of said authorization.
X	X	X	X	X	X	X	X	(32)	This line is to be completed and signed by an authorized representative of the manufacturer.
X	X	X	X	X	X	X	(33)	This certificate is to be completed by the Authorized Inspection Agency representative who performs the in-shop inspection.
...	X	X	X	(34)	Indicate the data items covered on the applicable form by line numbers.
X	X	X	X	(35)	Indicate by line numbers those items furnished by others and for which the applicable Manufacturer's Partial Data Reports have been examined.
X	X	X	X	X	X	X	X	(36)	The Inspector's National Board Authorized Inspector commission number must be shown.
X	X	X	(37)	The assembler's ASME Certificate of Authorization number and date of expiration of said authorization.
X	X	X	(38)	This line to be completed, when applicable, and signed by an authorized representative of the organization responsible for field assembly of the boiler.
X	X	X	(39)	This certificate to be completed by the Authorized Inspection Agency representative who performs the field assembly inspection.
X	X	X	(40)	Indicate by line numbers from the applicable Manufacturer's Data Report those items inspected in the field that were not inspected in the shop.
...	X	X	X	X	X	X	(41)	Nominal thickness of plate.
...	...	X	X	(42)	Minimum thickness after forming.
...	...	X	X	(43)	Radius on concave side of dish.
...	...	X	X	(44)	Shop hydrostatic test, if any, applied to individual part prior to test applied to the assembled boiler (see lines 33 and 35).
...	...	X	X	(45)	This line for headers not covered as items 7 through 10. It is intended primarily for sectional headers on straight tub watertube boilers.
...	...	X	X	X	X	...	(46)	Indicate shape as flat, dished, ellipsoidal, torispherical, or hemispherical.
...	...	X	X	(47)	Use inside dimensions for size.
...	...	X	X	(48)	Indicate shape as square, round, etc.
...	...	X	X	(49)	Outside diameter.
...	...	X	(50)	Minimum thickness of tubes.
...	...	X	X	(51)	Size.
...	...	X	X	(52)	Describe type as flanged, welding neck, etc.
...	X	X	...	(53)	Show name of part (e.g., steam drum, waterwall header).
...	X	X	...	(54)	Show data line number on applicable Manufacturer's Partial Data Report for the named part.
...	X	X	X	X	X	...	(55)	Any additional information to clarify the Manufacturer's Data Report should be entered here.
...	X	X	(56)	List each individual section that makes up boiler assembly. Show pattern and/or part number for each section. Show drawing number for each section. Show metal thickness for each section as indicated on the drawings. List each section of the complete boiler.
...	X	X	(57)	Show bursting pressure of each section of boiler. Show thickness measured at the break or fracture of each section. Indicate weight of each section.

**Table 4-1
Guide for the Preparation of Section IV Manufacturer's Data Report Forms (Cont'd)**

Applies to Form										Reference to Circled Numbers in the Forms	Instructions
H-1	H-2	H-3	H-4	H-5	H-5A	H-6	HLW-6	HLW-7	HLW-8		
...	X	(58)	Indicate minimum specified tensile strength for the class of iron as set forth in Table HC-300.
...	X	X	(59)	Indicate sections of boiler that represent specimen test bars. Show results of each specimen tested (tensile strength).
X	X	(60)	Show maximum allowable working pressure as determined by Formula HC-402 and by values allowed by Formula HC-402.
...	X	X	X	(61)	The individual designated to conduct tests, the designated manufacturer's representative who witnesses test and date or dates on which destruction tests were conducted.
...	X	X	(62)	Designated responsible engineering head certifying the tests and date.
...	X	(63)	Show quantity and dimensions.
...	X	X	...	(64)	Type of lining, if applicable.
X	X	X	X	(65)	Maximum allowable working pressure established in accordance with HLW-300 or HLW-500 of Section IV.
...	X	X	...	(66)	Indicate maximum allowable input, _____. For tanks used for storage, indicate "storage only."
X	X	X	...	(67)	Maximum temperature in accordance with HLW-300 of Section IV.
X	X	X	...	(68)	Hydrostatic pressure applied in accordance with HLW-505 of Section IV and witnessed by the Authorized Inspector.
...	X	(69)	Part of vessel yielding first should be indicated.
...	X	(70)	Pressure at which yielding occurs as evidenced by flaking of the brittle coating or by appearance of strain lines.
...	X	(71)	Show yield strength for each of the three specimens and average of the three.
...	...	X	X	...	(72)	This ID number is a unique identifying number for this form, which may be assigned by the Certificate Holder if desired.
X	X	X	X	(73)	Maximum water temperature.
...	X	(74)	Fill in information identical to that shown on the Manufacturer's Data Report Form to which this sheet is supplementary.
...	X	(75)	Indicate minimum specified tensile strength for the aluminum alloy as set forth in Section II, Part D, Table 6B.
...	X	(76)	Show maximum allowable working pressure as determined by Formula HA-402.

GENERAL NOTE: Any quantity to which units apply shall be entered on the Manufacturer's Data Report With the chosen units.

(23)

FORM H-1 MANUFACTURER'S MODULAR MASTER DATA REPORT FOR MODULAR BOILERS OR MODULAR WATER HEATERS As Required by the Provisions of the ASME Code Rules, Section IV

CERTIFIED AS (check one) H [] HLW []

Page ____ of ____

1. Manufactured and certified by _____ (name and address of manufacturer)

2. Manufactured for _____ (name and address of purchaser)

3. Location of installation _____ (name and address)

4. Identification of individual marked and certified boilers or water heaters combined to form a modular unit

- a) (boiler or water heater) (manufacturer's serial no.) (CRN) (National Bd. no.) (year built)
b) (boiler or water heater) (manufacturer's serial no.) (CRN) (National Bd. no.) (year built)
c) (boiler or water heater) (manufacturer's serial no.) (CRN) (National Bd. no.) (year built)
d) (boiler or water heater) (manufacturer's serial no.) (CRN) (National Bd. no.) (year built)
e) (boiler or water heater) (manufacturer's serial no.) (CRN) (National Bd. no.) (year built)
f) (boiler or water heater) (manufacturer's serial no.) (CRN) (National Bd. no.) (year built)

5. Identification of modular boiler or water heater with individual unmarked modules combined and certified as a complete modular boiler or water heater with associated Manufacturer's Data Reports listed in 9. below.

- a) (boiler or water heater) (manufacturer's serial no.) (CRN) (National Bd. no.) (year built)

6. The design conforms to ASME Code, Section IV, _____ (year) _____ [addenda (as applicable)(date)] _____ (Code Case no.)

7. MAWP 26 60 65 76 Maximum water temperature 67 73 Maximum input _____

8. (a) Shop hydro or pneumatic test 29 (boiler) Shop hydro test 68 (water heater)

8. (b) Field hydro test 29 (boiler) 68 (water heater)

9. Other items or remarks _____

(07/23)

FORM H-1 (BACK)

Page ____ of ____

CERTIFICATE OF SHOP COMPLIANCE

We certify that the statements made in this Manufacturer's Modular Master Data Report are correct and that all details of design, material, construction, and workmanship of this modular boiler or water heater conform to Section IV of the ASME BOILER AND PRESSURE VESSEL CODE.

"H" or "HLW" Certificate of Authorization no. ³¹ expires _____ , _____
Date ³² Signed _____ Name _____
(by representative) (manufacturer that constructed and certified boiler)

³³ CERTIFICATE OF SHOP INSPECTION

Modular boiler or water heater constructed by _____ at _____ .

I, the undersigned, holding a valid commission issued by the National Board of Boiler and Pressure Vessel Inspectors and employed by _____

have inspected this modular boiler or water heater and have examined the Manufacturer's Master Data/Data Reports for items and state that, to the best of my knowledge and belief, the manufacturer has constructed this modular boiler or water heater in accordance with the applicable sections of the ASME BOILER AND PRESSURE VESSEL CODE.

By signing this certificate neither the Inspector nor his employer makes any warranty, expressed or implied, concerning the modular boiler or water heater described in this Manufacturer's Modular Master Data Report. Furthermore, neither the Inspector nor his employer shall be liable in any manner for any personal injury or property damage or a loss of any kind arising from or connected with this inspection.

Date _____ Signed _____ Commission _____ ³⁶
(Authorized Inspector) (National Board Authorized Inspector Commission Number)

CERTIFICATE OF FIELD ASSEMBLY COMPLIANCE

We certify that the field assembly construction of all parts of this modular boiler or water heater conforms with the requirements of Section IV of the ASME BOILER AND PRESSURE VESSEL CODE.

"H" or "HLW" Certificate of Authorization no. ³⁷ expires _____ , _____ .
Date ³⁸ Signed _____ Name _____
(by representative) (assembler that certified and constructed field assembly)

³⁹ CERTIFICATE OF FIELD ASSEMBLY INSPECTION IF REQUIRED

I, the undersigned, holding a valid commission issued by the National Board of Boiler and Pressure Vessel Inspectors and employed by _____

have compared the statements in this Manufacturer's Modular Master Data Report with the described modular boiler or water heater and state that the parts referred to as related items ⁴⁰

_____, not included in the certificate of shop inspection, have been inspected by me and that to the best of my knowledge and belief the manufacturer and/or the assembler has constructed and assembled this modular boiler or water heater in accordance with the applicable sections of the ASME BOILER AND PRESSURE VESSEL CODE. The described modular boiler or water heater was inspected and subjected to a hydrostatic test of ²⁹ ⁶⁸ .

By signing this certificate neither the Inspector nor his employer makes any warranty, expressed or implied, concerning the modular boiler or water heater described in this Manufacturer's Data Report. Furthermore, neither the Inspector nor his employer shall be liable in any manner for any personal injury or property damage or a loss of any kind arising from or connected with this inspection.

Date _____ Signed _____ Commission _____ ³⁶
(Authorized Inspector) (National Board Authorized Inspector Commission Number)

(07/23)

(23)

**FORM H-2 MANUFACTURER'S DATA REPORT FOR ALL TYPES OF BOILERS
EXCEPT WATERTUBE AND THOSE MADE OF CAST IRON OR CAST ALUMINUM
As Required by the Provisions of the ASME Code Rules, Section IV
MANUFACTURER'S MASTER DATA REPORT (check one) YES NO Page _____ of _____**

1. Manufactured and certified by _____ (1)
(name and address of manufacturer)

2. Manufactured for _____ (2)
(name and address of purchaser)

3. Location of installation _____ (3)
(name and address)

4. Unit identification _____ (4) _____ (5) _____ (6) _____ (7) _____ (8) _____ (9)
(complete boiler, superheater, (manufacturer's serial no.) (CRN) (drawing no.) (National Bd. no.) (year built)
waterwall, etc.)

5. The chemical and physical properties of all parts meet the requirements of material specifications of the ASME BOILER AND PRESSURE VESSEL CODE. The design conforms to ASME Code, Section IV, _____ (7) _____ (8) _____ (9)
(year) [addenda (as applicable)(date)] (Code Case no.)

Manufacturer's Partial Data Reports properly identified and signed by Commissioned Inspectors have been furnished for the following items of this report _____ (10) _____ (11)
(name of part, item number, manufacturer's name, and identifying stamp)

6. Shells or drums _____ (10) _____ (11) _____ (12) _____ (13) _____ (14) _____ (15) _____ (16)
(no.) (material spec., gr.) (thickness) (inside diameter) [length (overall)] (inside diameter) [length (overall)]

7. Joints _____ (17) _____ (18) _____ (19) _____ (20)
[long. (seamless, welded)] [eff. (compared to seamless)] [girth (seamless, welded)] (no. of shell courses)

8. Tubesheet _____ (21) _____ (22) Tube holes _____ (23) _____ (24)
(material spec., grade) (thickness) (number and diameter)

9. Tubes: No. _____ (25) _____ (26) Diameter _____ (27) Length _____ (28) Gauge _____ (29)
(material spec., grade) (straight or bent) (if various, give max. and min.) (or thickness)

10. Heads _____ (30) _____ (31) _____ (32) _____ (33)
(material spec. no.) (thickness) (flat, dished, ellipsoidal) (radius of dish)

11. Furnace _____ (34) _____ (35) _____ (36) _____ (37) _____ (38) _____ (39) _____ (40) _____ (41) _____ (42) _____ (43) _____ (44) _____ (45) _____ (46) _____ (47) _____ (48) _____ (49) _____ (50)
(material spec., gr.) (thickness) (no.) [size (O.D. or W x H)] [length (each section)] (total) [type (plain, corrugated, etc.)] Seams [type (seamless, welded)]

12. Staybolts _____ (51) _____ (52) _____ (53) _____ (54) _____ (55) _____ (56) _____ (57) _____ (58)
(no.) [size (diameter)] (material spec., gr.) (size) (telltale) (net area) [pitch (horizontal and vertical)] (MAWP)

13. Stays or braces:

Location	Material Spec.	Type	Number and Size	Pitch	Total Net Area	Fig. HG-343 L/I	Dist. Tubes to Shell	MAWP
(a) F.H. above tubes	(11)	(20)			(21)	(22)		
(b) R.H. above tubes								
(c) F.H. below tubes								
(d) R.H. below tubes								
(e) Through stays								

14. Other parts: 1. _____ (23) 2. _____ (24) 3. _____ (25)
(brief description, i.e., dome, boiler piping)

1. _____ (26) _____ (27)
(material spec., grade, size, material thickness, MAWP)

2. _____ (28)

3. _____ (29)

15. Nozzles, inspection, and pressure relief valve openings: _____ (25)

Purpose (inlet, outlet, drain, etc.)	No.	Diameter or Size	Type	How Attached	Material	Nominal Thickness	Reinforcement Material	Location
Handhole					NA		NA	
Manhole					(11)			

(07/23)

Manufactured by _____ ①

Mfr's Serial No. _____ ⑤ National Board No. _____ ⑤

16. Boiler supports _____ (no.) _____ [type (saddles, legs, lugs)] _____ [attachment (bolted or welded)]

17. MAWP _____ ②⑥ Based on _____ ②⑦ Heating surface _____ ②⑧ Shop hydro. test _____ ②⑨
(Code par. and/or formula) (total) (complete boiler)

18. Maximum water temperature _____ ⑦③

19. Remarks _____

CERTIFICATE OF SHOP COMPLIANCE
We certify that the statements made in this data report are correct and that all details of design, material, construction, and workmanship of this boiler conform to Section IV of the ASME BOILER AND PRESSURE VESSEL CODE. "H" Certificate of Authorization no. _____ ③① expires _____, _____. Date _____ ③② Signed _____ Name _____ <small>(by representative) (manufacturer that constructed and certified boiler)</small>
③③ CERTIFICATE OF SHOP INSPECTION
Boiler constructed by _____ at _____ I, the undersigned, holding a valid commission issued by the National Board of Boiler and Pressure Vessel Inspectors and employed by _____ _____ have inspected parts of this boiler referred to as data items _____ ③④ and have examined Manufacturer's Partial Data Reports for items _____ ③⑤ and state that, to the best of my knowledge and belief, the manufacturer has constructed this boiler in accordance with the applicable sections of the ASME BOILER AND PRESSURE VESSEL CODE. By signing this certificate neither the Inspector nor his employer makes any warranty, expressed or implied, concerning the boiler described in this Manufacturer's Data Report. Furthermore, neither the Inspector nor his employer shall be liable in any manner for any personal injury or property damage or a loss of any kind arising from or connected with this inspection. Date _____ Signed _____ Commission _____ ③⑥ <small>(Authorized Inspector) (National Board Authorized Inspector Commission Number)</small>
CERTIFICATE OF FIELD ASSEMBLY COMPLIANCE
We certify that the field assembly construction of all parts of this boiler conforms with the requirements of Section IV of the ASME BOILER AND PRESSURE VESSEL CODE. "H" Certificate of Authorization no. _____ ③⑦ expires _____, _____. Date _____ ③⑧ Signed _____ Name _____ <small>(by representative) (assembler that certified and constructed field assembly)</small>
③⑨ CERTIFICATE OF FIELD ASSEMBLY INSPECTION
I, the undersigned, holding a valid commission issued by the National Board of Boiler and Pressure Vessel Inspectors and employed by _____ _____ have compared the statements in this Manufacturer's Data Report with the described boiler and state that the parts referred to as data items _____ ④①, not included in the certificate of shop inspection, have been inspected by me and that to the best of my knowledge and belief the manufacturer and/or the assembler has constructed and assembled this boiler in accordance with the applicable sections of the ASME BOILER AND PRESSURE VESSEL CODE. The described boiler was inspected and subjected to a hydrostatic test of _____ ②⑨ By signing this certificate neither the Inspector nor his employer makes any warranty, expressed or implied, concerning the boiler described in this Manufacturer's Data Report. Furthermore, neither the Inspector nor his employer shall be liable in any manner for any personal injury or property damage or a loss of any kind arising from or connected with this inspection. Date _____ Signed _____ Commission _____ ③⑩ <small>(Authorized Inspector) (National Board Authorized Inspector Commission Number)</small>

(07/17)

(23)

**FORM H-3 MANUFACTURER'S DATA REPORT FOR WATERTUBE BOILERS
AND ECONOMIZERS**
As Required by the Provisions of the ASME Code Rules, Section IV
MANUFACTURER'S MASTER DATA REPORT (check one) YES NO

Page _____ of _____

1. Manufactured and certified by _____ (1)
(name and address of manufacturer)
2. Manufactured for _____ (2)
(name and address of purchaser)
3. Location of installation _____ (3)
(name and address)
4. Unit identification _____ (4) _____ (5) _____ (6) _____ (7)
(complete boiler, superheater, waterwall, economizer, etc.) (manufacturer's serial no.) (CRN) (drawing no.) (National Bd. no.) (year built)
5. The chemical and physical properties of all parts meet the requirements of material specifications of the ASME BOILER AND PRESSURE VESSEL CODE. The design conforms to ASME Code, Section IV, _____ (7) _____ (8) _____ (9)
(year) [addenda (as applicable)(date)] (Code Case no.)

6. (a) Drums:

No.	Inside Diameter	Inside Length	Shell Plates			Tube Sheets		Tube Hole Ligament Efficiency, %	
			Material Spec. Grade	Thickness	Inside Radius	Thickness	Inside Radius	Longitudinal	Circumferential
1			(11)	(41)		(41)			
2									

No.	Longitudinal Joints		Circum. Joints		Heads				Hydro-static Test
	No. & Type*	Efficiency	No. & Type	Efficiency	Material Spec. Grade	Thickness	Type**	Radius of Dish	
1					(11)	(42)		(43)	(44)
2									

*Indicate if (1) seamless, (2) fusion welded.

**Indicate if (1) flat, (2) dished, (3) ellipsoidal, (4) hemispherical.

6. (b) Boiler tubes:

Diameter	Thickness	Material Spec. No. Grade	No.	How Attached

6. (c) Headers no _____ (45) _____ (11) _____ (41) or (42)
(box or sinuous or round, material spec. no., thickness)
- Heads or ends _____ (46) _____ (11) _____ (42) Hydro. test _____ (44)
(shape, material spec. no., thickness)

6. (d) Staybolts _____ (11)
(material spec. no., diameter, size telltale, net area)
- Pitch _____ Net area _____ Design pressure _____
(supported by one bolt)
6. (e) Mud drum _____ (47) _____ (48) _____ (11) _____ (41) or (42) Heads or ends _____ (48) _____ (11) _____ (42) Hydro. test _____ (44)
(for sect. header boilers state size, shape, material spec. no., thickness) (shape, material spec. no., thickness)

7. Waterwall headers:

No.	Size and Shape	Material Spec. No. Gr.	Thickness	Shape	Thickness	Material Spec. No. Gr.	Hydro. Test	Diameter	Thickness	Material Spec. No. Gr.
1	(47) (48)	(11)	(41) or (42)	(48)	(42)	(11)	(44)	(48)	(50)	(11)
2										
3										

8. (a) Other parts or economizers (1) _____ (2) _____ (3) _____ (b) Tubes for other parts or economizers _____
- | | | | | | | | | | | |
|---|--|--|--|--|--|--|--|--|--|--|
| 1 | | | | | | | | | | |
| 2 | | | | | | | | | | |
| 3 | | | | | | | | | | |

9. Nozzles, inspection, and pressure relief valve openings: (29)

Purpose (inlet, outlet, drain, etc.)	No.	Diameter or Size	Type	How Attached	Material	Nom. Thickness	Reinforcement Material	Location
Handhole		(61)	(62)		NA		NA	
Manhole					(11)			

(07/23)

Manufactured by _____ ①

Mfr's Serial No. _____ ⑤ National Board No. _____ ⑤

10.

		MAWP	Maximum water temp.	Shop Hydro. Test	Heating Surface
a	Boiler	②⑥	⑦③		
b	Waterwall				
c	Superheater				
d	Other parts				
e	Economizers				

Heating surface to be stamped on drum heads. This heating surface not to be used for determining minimum pressure relief valve capacity.

11. Field Hydro. Test

12. Manufacturer's Partial Data Reports properly identified and signed by Commissioned Inspectors have been furnished for the following items of this report _____ ③① ③⑤

(name of part, item number, manufacturer's name, and identifying stamp)

13. Remarks _____

CERTIFICATE OF SHOP COMPLIANCE

We certify that the statements made in this data report are correct and that all details of design, material, construction, and workmanship of this boiler conform to Section IV of the ASME BOILER AND PRESSURE VESSEL CODE.

"H" Certificate of Authorization No. _____ ③① expires _____, _____.

Date _____ ③② Signed _____ Name _____
(by representative) (manufacturer that constructed and certified boiler)

③③ CERTIFICATE OF SHOP INSPECTION

Boiler constructed by _____ at _____.

I, the undersigned, holding a valid commission issued by the National Board of Boiler and Pressure Vessel Inspectors and employed by _____

_____ have inspected parts of this boiler referred to as data items _____ ③④ and have examined Manufacturer's Partial Data Reports for items _____ ③⑤ and state that, to the best of my knowledge and belief, the manufacturer has constructed this boiler in accordance with Section IV of the ASME BOILER AND PRESSURE VESSEL CODE.

By signing this certificate neither the inspector nor his employer makes any warranty, expressed or implied, concerning the boiler described in this Manufacturer's Data Report. Furthermore, neither the inspector nor his employer shall be liable in any manner for any personal injury or property damage or a loss of any kind arising from or connected with this inspection.

Date _____ Signed _____ Commission _____ ③⑥
(Authorized Inspector) (National Board Authorized Inspector Commission Number)

CERTIFICATE OF FIELD ASSEMBLY COMPLIANCE

We certify that the field assembly construction of all parts of this boiler conforms with the requirements of Section IV of the ASME BOILER AND PRESSURE VESSEL CODE.

"H" Certificate of Authorization no. _____ ③⑦ expires _____, _____.

Date _____ ③⑧ Signed _____ Name _____
(by representative) (assembler that certified and constructed field assembly)

③⑨ CERTIFICATE OF FIELD ASSEMBLY INSPECTION

I, the undersigned, holding a valid commission issued by the National Board of Boiler and Pressure Vessel Inspectors and employed by _____

_____ have compared the statements in this Manufacturer's Data Report with the described boiler and state that the parts referred to as data items _____ ④① not included in the certificate of shop inspection, have been inspected by me and that to the best of my knowledge and belief the manufacturer and/or the assembler has constructed and assembled this boiler in accordance with Section IV of the ASME BOILER AND PRESSURE VESSEL CODE. The described boiler was inspected and subjected to a hydrostatic test of _____.

By signing this certificate neither the inspector nor his employer makes any warranty, expressed or implied, concerning the boiler described in this Manufacturer's Data Report. Furthermore, neither the inspector nor his employer shall be liable in any manner for any personal injury or property damage or a loss of any kind arising from or connected with this inspection.

Date _____ Signed _____ Commission _____ ③⑩
(Authorized Inspector) (National Board Authorized Inspector Commission Number)

(07/21)

(23)

FORM H-4 MANUFACTURER'S PARTIAL DATA REPORT
As Required by the Provisions of the ASME Code Rules
(Attach to the Applicable Data Report, Section IV)

Page _____ of _____

1. Manufactured and certified by _____ (1) _____ H-4 ID# _____ (72)
(name and address of manufacturer)
2. Manufactured for _____ (2) _____
(name and address of purchaser)
3. Location of installation _____ (3) _____
(name and address)

4. Identification of part(s):

Name of Part (53)	Line No. (54)	Manufacturer's Serial No. (5)	Manufacturer's Drawing No.	CRN	National Bd. No.	Year Built (6)

5. The chemical and physical properties of all parts meet the requirements of material specifications of the ASME BOILER AND PRESSURE VESSEL CODE. The design, construction, and workmanship conform to ASME Code, Section IV, _____ (7) _____ (8) _____ (9)
(year) [addenda (as applicable)](date) (Code Case no.)

6. (a) Drums:

No.	Inside Diameter	Inside Length	Shell Plates			Tube Sheets		Tube Hole Ligament Efficiency, %	
			Material Spec. No. Grade (11)	Thickness (41)	Inside Radius	Thickness (41) or (42)	Inside Radius	Longitudinal	Circumferential
1									
2									

No.	Longitudinal Joints		Circum. Joints		Heads				Hydro-static Test (44)
	No. & Type* (1)	Efficiency	No. & Type (1)	Efficiency	Material Spec. No. Grade (11)	Thickness (41) or (42)	Type**	Radius of Dish (43)	
1									
2									

*Indicate if (1) seamless, (2) fusion welded.

**Indicate if (1) flat, (2) dished, (3) ellipsoidal, (4) hemispherical.

6. (b) Boiler tubes:

Diameter	Thickness	Material Spec. No. Grade	No.	How Attached

6. (c) Headers no _____ (45) _____ (11) _____ (41) or (42)
(box or sinuous or round, material spec. no., thickness)

Heads or ends _____ (48) _____ (11) _____ (41) or (42) Hydro. test _____ (44)
(shape, material spec. no., thickness)

6. (d) Staybolts _____ (11)
(material spec. no. diameter, size telltale; net area)

Pitch _____ Net area _____ Design pressure _____
(supported by one bolt)

6. (e) Mud drum _____ (47) _____ (48) _____ (11) _____ (41) or (42) Heads or ends _____ (48) _____ (11) _____ (41) or (42) Hydro. test _____ (44)
(for sect. header boilers, state size, shape, material spec. no., thickness) (shape, material spec. no., thickness)

7. Waterwall headers:

No.	Size and Shape (47)	Material Spec. No. Gr. (11)	Thickness (41) or (42)	Heads or Ends			Hydro Test (44)	Waterwall Tubes		
				Shape (48)	Thickness (41) or (42)	Material Spec. No. Gr. (11)		Diameter (49)	Thickness (50)	Material Spec. No. Gr. (11)
1										
2										
3										

8. (a) Other parts (1) _____ (2) _____ (3) _____ (b) Tubes for other parts _____

1										
2										
3										

(07/17)

FORM H-4 (Back)

Manufactured by _____ ①

H-4 ID# _____ ②

9. Nozzles, inspection and pressure relief valve openings: ③

Purpose (inlet, outlet, drain, etc.)	No.	Diameter or Size	Type	How Attached	Material	Nom. Thickness	Reinforcement Material	Location
Handhole		④	⑤		NA		NA	

10.

		MAWP	Maximum Water Temp.	Shop Hydro. Test	Heating Surface		11. Field Hydro. Test
a	Boiler	⑥	⑦			{ Heating surface or kW to be stamped on drum heads This heating surface not to be used for determining minimum pressure relief valve capacity.	
b	Waterwall						
c	Other parts						

12. Remarks _____ ⑧

CERTIFICATE OF SHOP COMPLIANCE

We certify that the statements made in this partial data report are correct and that all details of design, material, construction, and workmanship of these parts conform to Section IV of the ASME BOILER AND PRESSURE VESSEL CODE.

"H" or "PRT IV" Certificate of Authorization no. _____ ⑨ expires _____.

Date _____ ⑩ Signed _____ Name _____
(by representative) (manufacturer that constructed and certified boiler)

⑪ CERTIFICATE OF SHOP INSPECTION

I, the undersigned, holding a valid commission issued by the National Board of Boiler and Pressure Vessel Inspectors and employed by _____

_____ have inspected the part of a boiler described in this Manufacturer's Partial Data Report on _____, _____, and state that to the best of my knowledge and belief, the manufacturer has constructed this part in accordance with Section IV of the ASME BOILER AND PRESSURE VESSEL CODE. By signing this certificate neither the Inspector nor his employer makes any warranty, expressed or implied, concerning the part described in this Manufacturer's Partial Data Report. Furthermore, neither the Inspector nor his employer shall be liable in any manner for any personal injury or property damage or a loss of any kind arising from or connected with this inspection.

Date _____ Signed _____ Commission _____ ⑫
(Authorized Inspector) (National Board Authorized Inspector Commission Number)

(07/23)

(23)

**FORM H-5 MANUFACTURER'S MASTER DATA REPORT FOR BOILERS
CONSTRUCTED FROM CAST IRON
As Required by the Provisions of the ASME Code Rules, Section IV**

Page _____ of _____

1. Manufactured and certified by _____ ①
(name and address of manufacturer) (foundry identification)

2. Boiler type or model no. _____ ④

3. Boiler section data: ⑤⑥

Section Designation (list each individual section in boiler assembly)	Pattern and/or Part No.	Metal Thickness According to Drawing
(a) _____	_____	_____
(b) _____	_____	_____
(c) _____	_____	_____
(d) _____	_____	_____
(e) _____	_____	_____

4. Boiler section bursting data: ⑤⑦

Section Designation	Bursting Pressure, Metal Thickness Measured at <i>Break or Fracture, and Weight of Section</i>		
	Test No. 1	Test No. 2	Test No. 3
(a) _____	_____	_____	_____
(b) _____	_____	_____	_____
(c) _____	_____	_____	_____
(d) _____	_____	_____	_____
(e) _____	_____	_____	_____

5. Minimum specified tensile strength _____ ⑤⑧ .

6. Tensile strength of associated test bars: ⑤⑨

Section Designation	Bar for Test No. 1	Bar for Test No. 2	Bar for Test No. 3
(a) _____	_____	_____	_____
(b) _____	_____	_____	_____
(c) _____	_____	_____	_____
(d) _____	_____	_____	_____
(e) _____	_____	_____	_____

7. Specification no. and class of gray iron _____

8. Maximum Allowable working pressure of boiler* _____ ⑥⑩

*Determined by using formula in HC-402 and by selection of lowest values of bursting pressure from tests recorded in item 4 of this report.

(07/15)

Manufactured by _____ ① _____

Boiler type or model no. _____ ④ _____

9. Sketch of section with lowest bursting pressure:

Show location of failure and indicate whether principally in bending or tension.

10. Examination data: ⑥

(a) Test engineer _____ (name)

(b) Witness of test(s) _____ (name)

(c) Date(s) of destruction tests _____

11. Manufacturer's certification: ⑦

Date _____, _____

Certified to be true record

(name and title)

12. ASME Certificate of Authorization no. _____ ⑧ _____ to use the Certification Mark with H designator (cast iron).

Certificate expires _____, _____

(23)

Page _____ of _____

**FORM H-5A MANUFACTURER'S MASTER DATA REPORT FOR BOILERS
CONSTRUCTED FROM CAST ALUMINUM**
As Required by the Provisions of the ASME Boiler and Pressure Vessel Code Rules, Section IV

1. Manufactured and certified by _____ (1)
(name and address of manufacturer) (foundry identification)

2. Boiler type or model no. _____ (4)

3. Boiler section data: (56)

Section Designation (List Each Individual Section in Boiler Assembly)	Pattern and/or Part No.	Metal Thickness According to Drawing
(a) _____	_____	_____
(b) _____	_____	_____
(c) _____	_____	_____
(d) _____	_____	_____
(e) _____	_____	_____

4. Boiler section bursting data: (57)

Section Designation	Bursting Pressure, Metal Thickness Measured at Break or Fracture, and Weight of Section		
	Test No. 1	Test No. 2	Test No. 3
(a) _____	_____	_____	_____
(b) _____	_____	_____	_____
(c) _____	_____	_____	_____
(d) _____	_____	_____	_____
(e) _____	_____	_____	_____

5. Minimum specified tensile strength _____ (75)

6. Tensile strength of associated test bars: (59)

Section Designation	Bar for Test No. 1	Bar for Test No. 2	Bar for Test No. 3
(a) _____	_____	_____	_____
(b) _____	_____	_____	_____
(c) _____	_____	_____	_____
(d) _____	_____	_____	_____
(e) _____	_____	_____	_____

7. Specification no. of aluminum alloy _____

8. Maximum allowable working pressure of boiler¹ _____ (76)

¹ Determined by using formula in HA-402 and by selection of lowest values of bursting pressure from tests recorded in item 4 of this report.

Manufactured by _____ ① _____

Boiler type or model no. _____ ④ _____

9. Sketch of section with lowest bursting pressure (show location of failure)

10. Examination data: ⑩

(a) Test engineer _____ (name)

(b) Certified Individual _____ (name)

(c) Date(s) of destruction tests _____

11. Manufacturer's certification: ⑫

Date _____ , _____

Certified to be true record

(name and title)

12. ASME Certificate of Authorization no. _____ ⑬ _____ to use the Certification Mark with H designator (cast aluminum).

Certificate expires _____ , _____

(07/23)

FORM HLW-6 MANUFACTURER'S DATA REPORT FOR WATER HEATERS OR STORAGE TANKS
As Required by the Provisions of the ASME Code Rules, Section IV
MANUFACTURER'S MASTER DATA REPORT (check one) YES NO Page _____ of _____

1. Manufactured and certified by _____
(name and address of manufacturer)
2. Manufactured for _____
(name and address of purchaser)
3. Location of installation _____
(name and address)
4. Identification _____
(manufacturer's serial no.) (CRN) (drawing no.) (National Board no.) (year built)
5. The chemical and physical properties of all parts meet the requirements of material specifications of the ASME BOILER AND PRESSURE VESSEL CODE. The design conforms to Part HLW, Section IV _____
(year) [addenda (as applicable)](date)] (Code Case no.)
6. Shell _____
(no.) (material spec., gr.) thickness (lining) (diameter) [length (overall)]
7. Joints _____
[long. (seamless, welded)] [eff. (compared to seamless)] [girth (seamless, welded)] (no. of shell courses)
8. Heads _____

Location	Material Spec., Gr., Thickness	Crown Radius	Knuckle Radius	Elliptical Ratio	Flat Diameter	Side Pressure (concave, convex)

9. Tubesheet _____ Tubes _____
(material spec., gr.) (no.) (size) [length (overall)] (material spec., gr.) (thickness) (rolled or welded)

10. Nozzles, inspection, and pressure relief valve openings: _____

Purpose (inlet, outlet, drain, etc.)	No.	Diameter or Size	Type	How Attached	Material	Nominal Thickness	Reinforcement Material	Location
Handhole			NA		NA		NA	

11. MAWP _____ Max. input _____ Max. temp. _____ Hydrostatic test _____

12. Manufacturer's Partial Data Reports properly identified and signed by Commissioned Inspectors have been furnished for the following items of this report _____

(name of part, item no., manufacturer's name, identification stamps)

13. Remarks _____
- _____
- _____
- _____
- _____
- _____
- _____
- _____
- _____

(07/23)

FORM HLW-6 (Back)

Page _____ of _____

CERTIFICATE OF SHOP COMPLIANCE

We certify that the statements made in this data report are correct and that all details of design, material, construction, and workmanship of this water heater or storage tank conform to Section IV of the ASME BOILER AND PRESSURE VESSEL CODE.

"HLW" Certificate of Authorization no. _____⁽³¹⁾ expiration date _____.

Date _____⁽³²⁾ Name _____⁽³³⁾ Signed _____
(manufacturer that constructed and certified water heater or storage tank) (by representative)

CERTIFICATE OF SHOP INSPECTION

Constructed by _____⁽³³⁾ at _____
I, the undersigned, holding a valid commission issued by the National Board of Boiler and Pressure Vessel Inspectors and employed by _____

have inspected parts referred to as data items _____⁽³⁴⁾

and have examined Manufacturer's Partial Data Reports for items _____⁽³⁵⁾
and state that, to the best of my knowledge and belief, the manufacturer has constructed this water heater or storage tank in accordance with Section IV of the ASME BOILER AND PRESSURE VESSEL CODE.

By signing this certificate, neither the Inspector nor his employer makes any warranty, expressed or implied, concerning the water heater or storage tank described in this Manufacturer's Data Report. Furthermore, neither the Inspector nor his employer shall be liable in any manner for any personal injury or property damage or a loss of any kind arising from or connected with this inspection.

Date _____ Signed _____
(Authorized Inspector) Commission _____⁽³⁶⁾
(National Board Authorized Inspector Commission Number)

FORM HLW-7 MANUFACTURER'S PARTIAL DATA REPORT FOR WATER HEATERS AND STORAGE TANKS
As Required by the Provisions of the ASME Code Rules (Attach to the Applicable Form HLW-6 Data Report)

Page _____ of _____

(23)

1. Manufactured and certified by _____ (1) _____ HLW-7 ID# _____ (12)
(name and address of manufacturer)

2. Manufactured for _____ (2) _____
(name and address of purchaser)

3. Identification of part(s):

Name of Part	Line No.	Identifying No.	Manufacturer's Drawing No.	Year Built
(53)	(54)	(5)		(6)

4. The chemical and physical properties of all parts meet the requirements of material specifications of the ASME BOILER AND PRESSURE VESSEL CODE. The design conforms to Part HLW, Section IV _____ (7) _____ and Addenda (as applicable) to _____ (8) _____
(year) (date)

5. Shell _____ (63) _____ (11) _____ (41) _____ (64) _____ (63) _____
(no.) (material spec., gr.) (thickness) (lining) (diameter) [length (overall)]

6. Joints _____ (12) _____ (13) _____ (12) _____
[long. (seamless, welded)] [eff. (compared to seamless)] [girth (seamless, welded)] (no. of shell courses)

7. Heads _____ (46) _____

Location	Material Spec., Gr., Thickness	Crown Radius	Knuckle Radius	Elliptical Ratio	Flat Diameter	Side Pressure (concave, convex)

8. Tubesheet _____ (11) _____ Tube holes _____
(material spec., gr.) (no. and diameter)

9. Tubes _____ (no.) Size _____ Length _____ Material spec., gr. _____ (11) Thickness _____

10. Connections:

Purpose	No.	Size or Diameter	Material Spec., Gr.	Thickness	Reinforcement Material

11. MAWP _____ (65) Max. input _____ (66) Max. temp. _____ (67) Hydrostatic test _____ (68)

12. Remarks _____ (69) _____

FORM HLW-7 (Back)

CERTIFICATE OF SHOP COMPLIANCE

We certify the statements in this Manufacturer's Partial Data Report to be correct and that all details of material, construction, and workmanship of this water heater or storage tank conform to Section IV of the ASME BOILER AND PRESSURE VESSEL CODE.

Certificate of Authorization no. _____³¹_____ to use the Certification Mark with HLW or PRT IV designator expires _____ .

Date _____³²_____ Signed _____ by _____
(manufacturer that constructed and certified parts) (authorized representative)

³³ CERTIFICATE OF SHOP INSPECTION

I, the undersigned, holding a valid commission issued by the National Board of Boiler and Pressure Vessel Inspectors and/or the state or province of _____ and employed by _____ have inspected the part described in this Manufacturer's Partial Data Report on _____ and state that, to the best of my knowledge and belief, the manufacturer has constructed this part in accordance with Section IV of the ASME BOILER AND PRESSURE VESSEL CODE.

By signing this certificate, neither the inspector nor his employer makes any warranty, expressed or implied, concerning the part described in this Manufacturer's Partial Data Report. Furthermore, neither the inspector nor his employer shall be liable in any manner for any personal injury or property damage or a loss of any kind arising from or connected with this inspection.

Date _____ Signed _____ Commission _____
(Authorized Inspector) (National Board Authorized Inspector Commission Number)

(07/23)

**FORM HLW-8 MANUFACTURER'S MASTER DATA PROOF TEST REPORT
FOR WATER HEATERS OR STORAGE TANKS
As Required by the Provisions of the ASME Code Rules, Section IV**

1. Manufactured and certified by _____ ^①
(name and address)

2. Vessel type or model no. (HLW-500) _____ ^④

3. Vessel proof test data:

Vessel Parts	Description or Part No.	Material Spec., Gr., Thickness According to Drawing	Specified Yield Strength	Minimum Tensile
(a) _____		^① ^④		
(b) _____				
(c) _____				
(d) _____				
(e) _____				

4. Type of coating _____
(lime wash or other brittle coating)

5. Test data to determine yielding:

Part Designation Yielding	Yielding Pressure by Flaking of Coating or by Strain Lines	Location of Yielding Whether Bending or Tension (indicate on sketch)
^⑥	^⑦	^⑧

6. Yield strength of test specimens [HLW-502.1(c)]: (a) _____ ^⑦ (b) _____ (c) _____ Average _____

7. Maximum allowable working pressure of vessel _____ ^⑥ [determined by formulas in HLW-502.1(d)]

8. Examination data: ^⑥
 (a) Test engineer _____
 (b) Witness of test _____
 (c) Date(s) of proof test _____

MANUFACTURER'S CERTIFICATION

We certify that the above data is correct and that the proof test procedure conforms with HLW-500 of Section IV of the ASME BOILER AND PRESSURE VESSEL CODE.

ASME Certificate of Authorization no. _____ ^③ to use the Certification Mark with HLW designator expiration date _____

Date _____ ^③ Certified to be true record _____
(authorized representative)* (manufacturer)

*NOTE: Signature of manufacturer's designated responsible engineering representative is required.

^③ PROOF TEST CERTIFICATE

I, the undersigned, holding a valid commission issued by the National Board of Boiler and Pressure Vessel Inspectors and employed by _____
 have witnessed the proof test and the procedures conforming to HLW-500 of Section IV of the ASME BOILER AND PRESSURE VESSEL CODE.

By signing this certificate, neither the Inspector nor his employer makes any warranty, expressed or implied, concerning the water heater or storage tank described in this Manufacturer's Proof Test Report. Furthermore, neither the Inspector nor his employer shall be liable in any manner for any personal injury or property damage or a loss of any kind arising from or connected with the witnessing of this proof test.

Date _____ Signed _____ Commission _____ ^③
(Authorized Inspector) (National Board Authorized Inspector Commission Number)

MANDATORY APPENDIX 5

VACUUM BOILERS

5-100 SCOPE

Section IV Rules permit a boiler to operate with internal pressure or with a vacuum. Rules in this Appendix cover the minimum requirements for the design, fabrication, and inspection of a boiler for vacuum operation only. Exemptions from certain Section IV requirements are provided. All other requirements of Section IV shall be met.

5-200 MAXIMUM PRESSURE AND TEMPERATURE

(a) *Maximum Allowable Working Pressure.* The boiler shall be designed for 15 psi vacuum (100 kPa vacuum) [0 psi (0 kPa)]. This value shall be used in all calculations, in lieu of the requirements of [HG-300\(a\)](#).

(b) Maximum temperature shall not exceed 210°F (99°C).

5-300 DESIGN PARAMETERS

(a) The thickness of cylindrical shells under external pressure shall be calculated in accordance with [HG-312](#), except that, when boilers are designed for noncorrosive service at a maximum pressure difference between outside and inside of 15 psi (100 kPa), the thickness shall be not less than $\frac{1}{8}$ in. (3 mm).

(b) Rectangular boilers under external pressure shall have thicknesses calculated in accordance with Section VIII, Division 1, Mandatory Appendix 13, 13-8 and 13-9. For noncorrosive service only, the thickness shall be not less than $\frac{1}{8}$ in. (3 mm).

(c) Stays in compression shall meet the requirements of the following:

$$l/r \leq 50$$

where

l = length

r = radius of gyration

(d) The furnace thickness shall be calculated in accordance with [HG-301](#), using 15 psi (100 kPa) design pressure. For noncorrosive service only, the thickness shall be not less than $\frac{1}{8}$ in. (3 mm).

(e) Head thickness shall be calculated in accordance with [HG-305](#), [HG-306](#), or [HG-307](#), using 15 psi (100 kPa) design pressure, except that, when boilers are designed for noncorrosive service at a maximum pressure difference between outside and inside of 15 psi (100 kPa), the thickness shall be not less than $\frac{1}{8}$ in. (3 mm).

(f) Tube thickness shall be calculated in accordance with [HG-315](#).

(g) As an alternative to the calculations in (a) through (f), the vessel may be

(1) designed and constructed to Code requirements for an internal pressure of 30 psig (200 kPa) using the proof test requirements of [HG-501](#) or [HG-502](#). However, no external pressure rating may be shown with the Code marking unless Code requirements for external pressure are met (see [HG-503](#)).

(2) designed and constructed as a vacuum vessel for an external pressure of 15 psia (100 kPa) using the proof test requirements of [HG-503](#).

5-400 WELDING

(a) *Joint Efficiency.* No factor has to be used for parts designed for external pressure ($E = 1$). For the furnace joint, efficiencies shall be in accordance with [HW-702](#).

(b) Corner or tee joints shall be in accordance with [HW-701.3](#).

(c) Attachment welds shall be in accordance with [HW-731](#).

(d) Welding Qualifications shall be in accordance with ASME Section IX.

5-500 ALTERNATIVE TO HYDROTEST

A helium leak test, conducted at the maximum vacuum to which the boiler will be exposed, may be used in lieu of the hydrostatic test requirements specified in [HG-510](#). This test shall be witnessed by the authorized inspector. The test shall be conducted in accordance with Section V, Article 10, Mandatory Appendix IV or Mandatory Appendix V. Maximum acceptable leakage rate shall be as follows:

Appendix	Maximum Acceptable Leakage Rate, std cm ³ /sec
IV — Detector Probe	1×10^{-4}
V — Tracer Probe	1×10^{-5}
V — Hood	1×10^{-6}

5-600 INSTRUMENTS, FITTINGS, AND CONTROLS

Vacuum boilers shall be provided with instruments, fittings, and controls in accordance with [Articles 6](#) and [7](#) of [Part HG](#), but they are exempt from the following requirements if pressure and temperature controls are provided as described in [\(a\)](#), [\(b\)](#), and [\(c\)](#) below:

Paragraph	Title
HG-603	Gauge Glass
HG-604	Water Column
HG-605	Pressure Control (second control only)
HG-606	Low Water Cut-Off
HG-703.2	Return Pipe Connection
HG-705	Feedwater Connection
HG-715	Blowoff and Drain Valves

These exemptions are applicable only when the following devices are installed:

(a) Pressure Control. A pressure control that interrupts the burner operation in response to boiler pressure, and is set at 2.5 psig vacuum (12.2 psia) (17 kPa).

(b) Temperature Control. Two temperature controls responsive to boiler temperature that can interrupt burner operation, one shall operate at a temperature below 210°F (99°C), and the other shall prevent the temperature from exceeding 210°F (99°C) with no automatic recycle. The use of a fusible plug to perform the second of these two functions is permissible.

(c) Pressure Relief Valve. A pressure relief valve without a test lever, set at 7.1 psig (22 psia) (49 kPa gage) maximum pressure and sized in accordance with [HG-402A](#).

5-700 INSPECTION OPENINGS

Heat exchanger coil openings may be used to satisfy the requirements for inspection and access.

MANDATORY APPENDIX 6

STANDARD UNITS FOR USE IN EQUATIONS

Table 6-1
Standard Units for Use in Equations

Quantity	U.S. Customary Units	SI Units
Linear dimensions (e.g., length, height, thickness, radius, diameter)	inches (in.)	millimeters (mm)
Area	square inches (in. ²)	square millimeters (mm ²)
Volume	cubic inches (in. ³)	cubic millimeters (mm ³)
Section modulus	cubic inches (in. ³)	cubic millimeters (mm ³)
Moment of inertia of section	inches ⁴ (in. ⁴)	millimeters ⁴ (mm ⁴)
Mass (weight)	pounds mass (lbm)	kilograms (kg)
Force (load)	pounds force (lbf)	newtons (N)
Bending moment	inch-pounds (in.-lb)	newton-millimeters (N·mm)
Pressure, stress, stress intensity, and modulus of elasticity	pounds per square inch (psi)	megapascals (MPa)
Energy (e.g., Charpy impact values)	foot-pounds (ft-lb)	joules (J)
Temperature	degrees Fahrenheit (°F)	degrees Celsius (°C)
Absolute temperature	Rankine (°R)	kelvin (K)
Fracture toughness	ksi square root inches (ksi√in.)	MPa square root meters (MPa√m)
Angle	degrees or radians	degrees or radians
Boiler capacity	Btu/hr	watts (W)

MANDATORY APPENDIX 7

RULES FOR MASS-PRODUCTION OF HEATING BOILERS

7-100 INTRODUCTION

This Appendix provides detailed requirements for the mass-production of boilers with the Certification Mark with the H designator or vessels with the Certification Mark with the HLW designator at a rate of production that makes it impracticable for the Inspector to perform the duties normally assigned under [HG-515.3](#), [HG-515.4\(a\)](#), and [HLW-600.3](#). The provisions of this Appendix allow the Manufacturer to assume responsibility for carrying out some of the Inspector's normally assigned duties by the development, acceptance, and implementation of a detailed inspection and quality control procedure as described in [HG-515.4\(b\)](#) and [HLW-600.3\(f\)](#). The objective of such a procedure is to ensure that Code compliance and pressure integrity of mass-produced boilers with the Certification Mark with the H designator and vessels with the Certification Mark with the HLW designator remains essentially identical to boilers with the Certification Mark with the H designator constructed under [HG-515.4\(a\)](#) or vessels with the Certification Mark with the HLW designator constructed under [HLW-600.3\(a\)](#) through [HLW-600.3\(c\)](#). The Inspector must be satisfied the inspection and quality control procedure and the Quality Control System are being fully implemented, and completed boilers with the Certification Mark with the H designator or vessels with the Certification Mark with the HLW designator meet the applicable requirements of [HG-515](#) for boilers with the Certification Mark with the H designator and [HLW-600](#) for vessels with the Certification Mark with the HLW designator.

7-200 SCOPE

This Appendix provides rules allowing the Manufacturer to assume responsibility for carrying out some of the Inspector's duties of mass-produced boilers with the Certification Mark with the H designator normally assigned under [HG-515.3](#) and [HG-515.4\(a\)](#) or vessels with the Certification Mark with the HLW designator normally assigned under [HLW-600.3\(a\)](#) through [HLW-600.3\(c\)](#), in addition to the responsibilities normally assigned to the Manufacturer in [HG-515.2](#) and [HLW-600.2](#). A mass-production program for boiler with the Certification Mark with the H designator or vessels with the Certification Mark with the HLW designator fabri-

cation may be implemented when the requirements of this Appendix are met.

7-300 GENERAL

(a) Mass-production is defined as the construction of multiple boilers with the Certification Mark with the H designator or vessels with the Certification Mark with the HLW designator at a rate of production that makes it impracticable for the Inspector to perform all of the duties normally assigned. The Inspector and/or the Authorized Inspection Agency (AIA) shall determine the acceptability of applying the mass-production inspection and quality control procedure to the construction of any boiler with the Certification Mark with the H designator or vessels with the Certification Mark with the HLW designator or series of boilers with the Certification Mark with the H designator or vessels with the Certification Mark with the HLW designator.

(b) Construction of two or more boilers with the Certification Mark with the H designator or vessels with the Certification Mark with the HLW designator per shift at a rate of production that affords the Inspector sufficient opportunity to perform the required duties does not qualify for mass-production.

(c) Boilers with the Certification Mark with the H designator or vessels with the Certification Mark with the HLW designator constructed under this Appendix shall be identical, except for differences in fitting sizes and locations, shell lengths, and the location and configuration of nonpressure attachments.

(d) The design and construction of boilers with the Certification Mark with the H designator or vessels with the Certification Mark with the HLW designator fabricated under this Appendix shall be reviewed and accepted by the Inspector in accordance with the Certificate Holder's Quality Control System.

(e) There is no size limitation on mass-produced boilers with the Certification Mark with the H designator or vessels with the Certification Mark with the HLW designator.

7-400 QUALITY CONTROL PROCEDURES

(a) The Manufacturer and the Authorized Inspection Agency (AIA) of record shall collaborate on the preparation of a detailed inspection and quality control procedure

describing how some of the duties, of the Inspector, will be assumed by the Manufacturer. The inspection and quality control procedure, along with the Quality Control System Manual, shall be submitted to the AIA of record for review and acceptance in writing prior to implementation. The AIA of record shall submit the accepted inspection and quality control procedure and the Quality Control System Manual to the legal jurisdiction concerned, and to an ASME Designee for review and acceptance. The final approved version of the inspection and quality control procedure shall be included in the Manufacturer's written Quality Control System.

(b) The inspection and quality control procedure shall be implemented at the location of the Manufacturer named on the Certificate of Authorization. An Inspector employed and designated by the AIA of record shall be assigned at each Manufacturer's location where mass-production is being performed. The assigned Inspector shall perform the required duties, including verification and oversight of implementation of the inspection and quality control procedure as stated in (c) below. A minimum of one full-time (40 hr per week) Inspector shall be present during mass-production operations to perform the required duties. The Inspector shall be present at all times during mass production operations when operating less than 40 hr per week. When multiple shift mass-production operations are taking place, the required inspection frequency beyond the full-time requirement shall be a matter of agreement between the AIA of record and the Manufacturer, as set forth in the accepted inspection and quality control procedure. Manufacturing personnel who implement the inspection and quality control procedure shall be trained and qualified for their assigned duties in accordance with the Manufacturer's Quality Control System. All training and qualification documentation shall be maintained in accordance with the Manufacturer's Quality Control System.

(c) The Inspector shall perform all duties specifically assigned, and any necessary intermittent and unannounced in-process inspections and other inspection activities required to ensure boilers with the Certification Mark with the H designator or vessels with the Certification Mark with the HLW designator have been designed and constructed in accordance with the requirements of this Section prior to applying the Certification Mark. The Inspector's duties shall, as a minimum, include verifying that

- (1) the Manufacturer has a valid Certificate of Authorization and is working to a Quality Control System
- (2) the applicable design calculations are available
- (3) materials used in the construction shall comply with the requirements of this Section
- (4) all welding and brazing procedures have been qualified
- (5) all welders, welding operators, brazers, and brazing operators have been qualified

(6) material imperfections repaired by welding were acceptably repaired

(7) the inspection and quality control procedure is being implemented effectively, by monitoring all aspects of its implementation completely each calendar year

(8) the boiler with the Certification Mark with the H designator or vessels with the Certification Mark with the HLW designator is in compliance with all the provisions of this Code, to the best of their knowledge and belief, prior to signing the Certificate of Inspection on the Manufacturer's Data Report

(d) In addition to the responsibilities of the Manufacturer found in [HG-515.2](#), the Manufacturer is responsible for the following duties, as provided in the inspection and quality control procedure described in (a) above:

(1) verifying that weld defects were acceptably repaired

(2) making a visual examination of the vessel to confirm that the material identification numbers have been properly transferred

(3) making a visual examination of the vessel to confirm that there are no material or dimensional defects

(4) verifying that required surface examinations and other tests have been performed and that the results are acceptable

(5) performing internal and external examinations, and verifying that the hydrostatic test has been performed

(6) verifying that the nameplate has been attached to the boiler with the Certification Mark with the H designator or vessels with the Certification Mark with the HLW designator

(e) When the Manufacturer wishes to make changes to the accepted inspection and quality control procedure affecting compliance with the requirements of [HG-515.4\(b\)](#), the changes shall be subjected to review and acceptance, prior to implementation, by all parties required for a joint review, including the AIA of record, the jurisdiction concerned, and an ASME Designee. The AIA of record shall forward the accepted revisions, to the inspection and quality control procedure, to the legal jurisdiction, and the ASME Designee for their written acceptance.

7-500 MANUFACTURER'S DATA REPORTS (23)

(a) The Manufacturer's Data Report prepared by the Manufacturer for boilers with the Certification Mark with the H designator or vessels with the Certification Mark with the HLW designator constructed under a mass-production program shall include under "Remarks" the statement: "Constructed under the provisions of [HG-515.4\(b\)](#)." The Manufacturer's Data Report Forms shall be certified by the Manufacturer and Inspector when the completed heating boilers or

vessels are found to be in compliance with the requirements of this Section.

(b) Same-day construction of identical mass-produced boilers with the Certification Mark with the H designator or vessels with the Certification Mark with the HLW designator

may be reported on a single Manufacturer's Data Report when the requirements of [HG-515.4\(b\)](#) are met.

MANDATORY APPENDIX 8
(23) CRITERIA FOR REAPPLICATION OF A CERTIFICATION MARK

Reapplication of the ASME Single Certification Mark shall be in accordance with ASME CA-1.

MANDATORY APPENDIX 9

ESTABLISHING GOVERNING CODE EDITIONS, ADDENDA, AND CASES FOR HEATING BOILERS AND REPLACEMENT PARTS

9-100 GENERAL

After Code revisions are approved by ASME, they may be used beginning with the date of issuance shown on the Code. Except as noted below, revisions become mandatory 6 months after the date of issuance. Code Cases are permissible and may be used beginning with the date of approval by ASME. Only Code Cases that are specifically identified as being applicable to this Section may be used. At the time a Code Case is applied, only the latest revision may be used. Code Cases that have been incorporated into this Section or have been annulled shall not be used.

Changes to the Code and Code Cases related to design, material, fabrication, examination, inspection, testing, overpressure protection, and field assembly made prior to completion of the boiler or replacement part may be critical to the intended service conditions of the boiler. These changes must be considered by the Manufacturer. Application of such changes shall be a matter of agreement between the Manufacturer and the user.

As used in this Mandatory Appendix, the term "Authorized Inspector" shall be considered to include "Qualified Inspector" and "Certified Individual."

9-200 DESIGN

The Manufacturer of the completed boiler shall establish the Code edition, addenda, and Code Cases to be used for design of a boiler, including parts thereof, or a replacement part to be marked with the ASME Certification Mark required by this Section.

(a) Except as provided in (b) and (c), the Code edition and addenda used to design a boiler, parts thereof, and replacement parts shall be either those that are mandatory on the date the boiler or replacement part is contracted or those that have been approved and issued by ASME prior to the contract date but are not yet mandatory (refer to 9-100 above).

(b) Existing pressure parts that have been marked and certified to an earlier or later edition and addenda than those used for design and that have never been placed in service (i.e., placed in stock for future use) may be used, provided they are acceptable to the Manufacturer.

(c) It is permitted to provide a replacement part "in kind" (i.e., identical in fit and material to the part being replaced) for an existing boiler and to certify the part as meeting the Code edition and addenda to which the existing boiler is certified.

9-300 MATERIALS

For pressure-containing parts, the Manufacturer shall use material conforming to one of the specifications listed as approved for use in the edition and addenda specified for design. Also, the material specification edition must be listed as approved for use in the Guideline for Acceptable ASTM Editions or in the Guideline for Acceptable Non-ASTM Editions in Section II, Part A or Part B.

For replacement parts provided "in kind," the material shall be produced in accordance with the material specification revision listed as approved in Section II as described above at the time the part is certified.

9-400 FABRICATION

The edition and addenda used to govern fabrication shall be either those governing design or the edition and addenda approved and issued at the time the activity is performed.

9-500 EXAMINATION

Examination refers to activities performed by the Manufacturer that include nondestructive examination. The edition and addenda used to govern examination shall be either those governing design or the edition and addenda approved and issued at the time the activity is performed.

9-600 INSPECTION

Inspection refers to activities performed by the Inspector. The Code edition and addenda used to govern inspection shall be the same as those governing design.

9-700 TESTING

The Code edition and addenda used to govern testing of the item shall be the same as those governing design.

9-800 OVERPRESSURE PROTECTION

The Code edition and addenda used to govern overpressure protection shall be the same as those governing design.

9-900 FIELD ASSEMBLY

The edition and addenda used to govern field assembly shall be either those governing design or the edition and addenda approved and issued at the time the activity is performed.

9-1000 CERTIFICATION

The edition and addenda used to govern Code certification shall be the same as those governing design.

MANDATORY APPENDIX 10

REQUIREMENTS FOR FEEDWATER ECONOMIZERS

(23) 10-100 GENERAL

A feedwater economizer is a heat exchanger in which feedwater to be supplied to a boiler or water heater is heated by flue gasses exiting the boiler or water heater. When such an economizer is supplied with a Section IV boiler or water heater, it shall be a certified pressure vessel, which may be constructed in accordance with Section IV or in accordance with Section VIII, Division 1. Manufacturer's Data Reports for Section IV economizers shall be documented on [Form H-3](#).

10-200 DESIGN

(a) The maximum allowable working pressure (MAWP) of the primary (feedwater) side of the economizer shall not be less than the maximum feedwater supply pressure under any operating conditions.

(b) When used with a water heater certified in accordance with [Part HLW](#), water-wetted surfaces shall be corrosion resistant material.

10-300 PRESSURE RELIEF

(a) The Section IV economizer shall be provided with pressure relief valves sized in accordance with [HG-402A.2](#). Nonisolable economizers shall be provided with pressure relief valves in accordance with [HG-402A.2](#) or the required economizer relief valve capacity shall be included in the total capacity of the relief valves on the boiler or water heater. The total relief valve capacity need not exceed the input of the boiler. Isolable economizers shall have the pressure relief valve installed on the economizer.

(b) Economizers constructed to Section VIII, Division 1 shall be provided with overpressure protection in accordance with the requirements of Section VIII, Division 1, UG-150 through UG-156.

(c) In all cases, for both Section IV and Section VIII, Division 1 economizers, the heat absorption of the economizer shall be included in the economizer nameplate marking.

NONMANDATORY APPENDIX A

ESTIMATING PRESSURE RELIEF VALVE CAPACITY REQUIREMENTS

A-100 GUIDE FOR ESTIMATING PRESSURE RELIEF VALVE CAPACITY BASED ON HEATING SURFACE

The minimum pressure relief valve relieving capacity, when provided in accordance with [HG-402A](#), may be estimated on the basis of the pounds of steam generated per hour per square foot (kilogram per hour per square meter) of boiler or heating surface, as given in [Table A-100](#). In many cases, a greater relieving capacity of pressure relief valves will have to be provided than that estimated using [Table A-100](#), in order to meet the requirements of [HG-402A.1\(c\)](#) and [HG-402A.1\(i\)](#) or [HG-402A.2\(d\)](#) and [HG-402A.2\(f\)](#).

Table A-100
Guide for Estimating Steaming Capacity Based on Heating Surface

U.S. Customary Units		
Type of Surface	Pounds of Steam/(hr × ft ²)	
	Firetube Boilers	Watertube Boilers
Boiler heating surface		
Hand fired	5	6
Stoker fired	7	8
Oil, gas, or pulverized fuel fired	8	10
Waterwall heating surface		
Hand fired	8	8
Stoker fired	10	12
Oil, gas, or pulverized fuel fired	14	16
SI Units		
Type of Surface	Kilograms of Steam/(h × m ²)	
	Firetube Boilers	Watertube Boilers
Boiler heating surface		
Hand fired	24	29
Stoker fired	34	39
Oil, gas, or pulverized fuel fired	39	49
Waterwall heating surface		
Hand fired	39	39
Stoker fired	49	59
Oil, gas, or pulverized fuel fired	68	78

GENERAL NOTES:

- (a) When a boiler is fired only by a gas having a heat value not in excess of 200 Btu/ft³ (7 400 kJ/m³), the minimum pressure relief valve relieving capacity may be based on the values given for hand-fired boilers above.
- (b) The minimum pressure relief valve relieving capacity for electric boilers shall be 3½ lb/hr/kW (1.6 kg/h/kW) input.
- (c) For heating surface determination, see [HG-403A](#).

NONMANDATORY APPENDIX B

METHOD OF CHECKING PRESSURE RELIEF VALVE CAPACITY BY MEASURING MAXIMUM AMOUNT OF FUEL THAT CAN BE BURNED

B-100 PROCEDURE

The maximum quantity of fuel C that can be burned per hour at the time of maximum forcing is determined by a test. The maximum number of heat units per hour, or CH , is then determined, using the values of H given in B-102. The weight of steam generated per hour is found by the formula:

(U.S. Customary Units)

$$W = \frac{C \times H \times 0.75}{1,000}$$

(SI Units)

$$W = \frac{C \times H \times 0.75}{2\,326}$$

where

C = total weight or volume of fuel burned/hr at time of maximum forcing, lb or ft³

H = heat of combustion of fuel, Btu/lb or Btu/ft³ (see B-102)

W = weight of steam generated/hr, lb

The sum of the pressure relief valve capacities marked on the valves shall be equal to or greater than W .

B-101 EXAMPLES

Example 1. A boiler at the time of maximum forcing uses 2,150 lb of Illinois coal/hr of 12,100 Btu/lb.

$$C \times H = 2,150 \times 12,100 = 26,015,000$$

$$W = (C \times H \times 0.75) \div 1,000 = 19,511$$

Example 2. Wood shavings of heat of combustion of 6,400 Btu/lb are burned under a boiler at the maximum rate of 2,000 lb/hr.

$$C \times H = 2,000 \times 6,400 = 12,800,000$$

$$W = (C \times H \times 0.75) \div 1,000 = 9,600$$

Example 3. An oil-fired boiler at maximum forcing uses 1,000 lb of crude oil (Texas)/hr.

$$C \times H = 1,000 \times 18,500 = 18,500,000$$

$$W = (C \times H \times 0.75) \div 1,000 = 13,875$$

Example 4. A boiler fired with natural gas consumes 3,000 ft³/hr.

$$C \times H = 3,000 \times 960 = 2,880,000$$

$$W = (C \times H \times 0.75) \div 1,000 = 2,160$$

B-102 HEATS OF COMBUSTION OF FUELS

For the purpose of checking the pressure relief valve capacity as described in [B-100](#), the following values of heats of combustion of various fuels may be used:

Material	<i>H</i> = Btu/lb
Semibituminous coal	14,500
Anthracite	13,700
Screenings	12,500
Coke	13,500
Wood, hard or soft, kiln dried	7,700
Wood, hard or soft, air dried	6,200
Wood shavings	6,400

Table continued

Material	<i>H</i> = Btu/lb
Peat, air dried, 25% moisture	7,500
Lignite	10,000
Kerosene	20,000
Petroleum, crude oil, Pennsylvania	20,700
Petroleum, crude oil, Texas	18,500
Natural gas	960
Blast-furnace gas	100
Producer gas	150
Water gas, uncarbureted	290

NONMANDATORY APPENDIX C

EXAMPLES OF METHOD OF CALCULATING A WELDED RING REINFORCED FURNACE

C-100 FOR A STEAM OR HOT WATER BOILER

(a) Design Data [HG-300(a)]. 30 psi pressure (250°F); 36 in. (D_o) O.D.; 15 in. (L) center-to-center distance of reinforcing rings. Material is SA-285-C.

Use formulas from HG-312 where

D_o = outside diameter of furnace, in.

H_r = height of stiffening ring, in.

L = center-to-center distance between two adjacent stiffening rings, in.

P = design pressure, psi (30 psi min.) (per HG-300)

T_r = thickness of stiffening ring, in.

t = wall thickness of furnace, in.

(b) Selection of t and L (First Trial). Assume

$t = 1/4$ in. and $L = 15$ in.

$L/D_o = 15/36 = 0.417$, $D_o/t = 36/0.25 = 144$

Temperature: 500°F [see HG-312.1(b)]

Factor $A = 0.0025$ (from Section II, Part D, Subpart 3, Figure G)

Factor $B = 12,000$ (from Section II, Part D, Subpart 3, Figure CS-2)

$$P_a = \frac{B}{D_o/t} = \frac{12,000}{144} = 83 \text{ psi}$$

(c) Selection of T_r and H_r (First Trial) [HG-312.4(b)]. Assume

$$T_r = \frac{5}{16} \text{ in. and } H_r = 1.5 \text{ in.}$$

$$I = \frac{0.3125 \times 1.5^3}{12} = 0.0879 \text{ in.}^4$$

$$A_s = 0.3125 \times 1.5 = 0.469 \text{ in.}^2$$

(d) Determination of I_s (First Trial)

$$\text{Factor } B = \frac{PD_o}{t + \frac{A_s}{L}} = \frac{30 \times 36}{0.25 + \frac{0.469}{15}} = 3,840$$

From Figure CS-2,

Factor $A = 0.00028$

$$\begin{aligned} I_s &= \frac{D_o^2 L \left(t + \frac{A_s}{L} \right) A}{14} \\ &= \frac{36^2 \times 15 \left(0.25 + \frac{0.469}{15} \right) 0.00028}{14} \\ &= 0.109 \text{ in.}^4 \end{aligned}$$

Since I_s is greater than I (0.0879 in.^4), the assumed reinforcing ring is not acceptable. (A ring with a greater I must be selected or L must be reduced.)

(e) Selection of T_r and H_r (Second Trial). Assume

$$T_r = 0.3125 \text{ in., } H_r = 2.5 \text{ in., and } L = 15 \text{ in.}$$

$$\frac{H_r}{T_r} = \frac{2.5}{0.3125} = 8.0$$

$$I = \frac{0.3125 \times 2.5^3}{12} = 0.407 \text{ in.}^4$$

$$A_s = 0.3125 \times 2.5 = 0.781 \text{ in.}^2$$

(f) Determination of I_s (Second Trial)

$$\text{Factor } B = \frac{30 \times 36}{0.25 + \frac{0.781}{15}} = 3,575$$

From Figure CS-2,

Factor $A = 0.00026$

$$\begin{aligned} I_s &= \frac{36^2 \times 15 \left(0.25 + \frac{0.781}{15} \right) 0.00026}{14} \\ &= 0.109 \text{ in.}^4 \end{aligned}$$

Since I (0.407 in.^4) is greater than I_s , the assumed reinforcing ring is acceptable.

C-101 FOR A HOT WATER BOILER

(a) *Design Data.* 100 psi working pressure (250°F); 30 in. (D_o) O.D.; 30 in. (L) center-to-center distance of reinforcing rings. Material is SA-285-C.

Use formulas from HG-312 and same notation as in C-100(a).

(b) *Selection of t and L (First Trial).* Assume $t = \frac{1}{2}$ in. and $L = 30$ in.

$$L/D_o = 30/30 = 1 \text{ and } D_o/t = 30/0.500 = 60$$

Temperature: 500°F [see HG-312.1(b)]

Factor $A = 0.003$ (from Figure G)

Factor $B = 12,300$ (from Figure CS-2)

$$P_a = \frac{B}{D_o/t} = \frac{12,300}{60} = 205 \text{ psi}$$

(c) *Selection of T_r and H_r (First Trial).* Assume

$$T_r = \frac{3}{8} \text{ in. and } H_r = 2.25 \text{ in.}$$

$$I = \frac{0.375 \times 2.25^3}{12} = 0.356 \text{ in.}^4$$

$$A_s = 0.375 \times 2.25 = 0.843 \text{ in.}^2$$

(d) *Determination of I_s (First Trial)*

$$\begin{aligned} \text{Factor } B &= \frac{PD_o}{t + \frac{A_s}{L}} \\ &= \frac{100 \times 30}{0.500 + \frac{0.843}{30}} \\ &= 5,681 \end{aligned}$$

From Figure CS-2,

$$\text{Factor } A = 0.00042$$

$$\begin{aligned} I_s &= \frac{D_o^2 L \left(t + \frac{A_s}{L} \right) A}{14} \\ &= \frac{30^2 \times 30 \left(0.50 + \frac{0.843}{30} \right) (0.00042)}{14} \\ &= 0.428 \text{ in.}^4 \end{aligned}$$

Since I_s is greater than I (0.356 in.⁴), the assumed reinforcing ring is not acceptable. (A ring with a greater I must be selected or L must be reduced.)

(e) *Selection of L (Second Trial).* Assume

$$L = 22 \text{ in., } T_r = \frac{3}{8} \text{ in., and } H = 2.25 \text{ in.}$$

$$\frac{H_r}{T_r} = \frac{2.25}{0.375} = 6.0$$

$$L/D_o = \frac{22}{30} = 0.734$$

$$D_o/t = \frac{30}{0.500} = 60$$

(f) *Determination of I_s (Second Trial).* From Figure CS-2,

Factor $B = 13,250$

$$P_a = 13,250/60 = 221 \text{ psi}$$

$$I = 0.356 \text{ in.}^4 \text{ (as above)}$$

$$A_s = 0.843 \text{ in.}^2 \text{ (as above)}$$

$$\text{Factor } B = \frac{100 \times 30}{0.500 + \frac{0.843}{22}} = 5,573$$

From Figure CS-2,

$$\text{Factor } A = 0.00041$$

$$\begin{aligned} I_s &= \frac{30^2 \times 22(0.500 + \frac{0.843}{22})0.00041}{14} \\ &= 0.312 \text{ in.}^4 \end{aligned}$$

Since I_s is less than I (0.356 in.⁴), the assumed reinforcing ring is acceptable.

NONMANDATORY APPENDIX D

EXAMPLES OF METHODS OF COMPUTATION OF OPENINGS IN BOILER SHELLS

D-100 PAD REINFORCED OPENING

(a) *Design Data.* A boiler shell has a 6 in. connection as shown in [Figure D-100](#). The shell has an inside diameter of 60 in., a thickness of $\frac{9}{16}$ in. and a working pressure of 160 psi. The shell and pad material are in accordance with SA-285 Grade C.

(b) *Wall Thickness Required (See HG-301)*

$$t_r = \frac{P \times R}{S \times E - 0.6P}$$

$$= \frac{160 \times 30}{11,000 \times 1.0 - 0.6 \times 160} = 0.440 \text{ in.}$$

(c) *Size of Welds Required (See HW-731)*

$$\text{Inner fillet weld} = 1.41 \times 0.7 \times t_r = w_1$$

$$w_1 = 1.41 \times 0.7 \times 0.440 = 0.434 \text{ in.}$$

$$\text{Outer fillet weld} = 1.41 \times 0.5 \times t_r = w_2$$

$$w_2 = 1.41 \times 0.5 \times 0.440 = 0.310 \text{ in.}$$

A $\frac{1}{2}$ in. inner fillet weld and a $\frac{7}{16}$ in. outer fillet weld meet these minimum requirements.

(d) *Area of Reinforcement Required (See HG-321)*

$$A = d \times t_r \times F$$

$$= 7.50 \times 0.440 \times 1.0 = 3.300 \text{ in.}^2$$

(e) *Area of Reinforcement Provided (See HG-326)*

$$A_1 = (E_1 t - F t_r) d$$

$$= (1.0 \times 0.563 - 1.0 \times 0.440) 7.5 = 0.922 \text{ in.}^2$$

$$A_2 = t_e (d_p - d_o)$$

$$= 0.437 (12.50 - 6.00) = 2.841 \text{ in.}^2$$

$$A_3 = 2 \times \frac{1}{2} \times w_1^2 + 2 \times \frac{1}{2} \times w_2^2$$

$$= 2 \times \frac{1}{2} \times 0.500^2 + 2 \times \frac{1}{2} \times 0.437^2 = 0.441 \text{ in.}^2$$

Total area (0.922 + 2.841 + 0.441) provided = 4.204 in.²

(f) *Load to Be Carried by Welds (See HG-327.2)*

$$W = (d \times t_r - A_1) \times S$$

$$= (7.50 \times 0.440 - 0.922) \times 11,000 = 26,160 \text{ lb}$$

(g) *Unit Stresses (See HW-730.2)*

$$\text{Shear in fillet weld} = 0.49 \times 11,000$$

$$= 5,390 \text{ psi} = S_s$$

(h) *Strength of Connection Elements*

(1) *Inner Weld w_1 in Shear*

$$\frac{\pi}{2} d \times w_1 \times S_s = 1.57 \times 7.50 \times 0.500 \times 5,390$$

$$= 31,750 \text{ lb}$$

(2) *Outer Weld w_2 in Shear*

$$\frac{\pi}{2} d_p \times w_2 \times S_s = 1.57 \times 12.50 \times 0.437 \times 5,390$$

$$= 46,200 \text{ lb}$$

D-101 NOZZLE REINFORCED OPENING

(a) *Design Data.* A 4 in. SA-53 schedule 80 pipe is welded into a shell as shown in [Figure D-101](#). The shell has an inside diameter of 36 in., a thickness of

Figure D-100
Computation of Typical Pad Reinforcement

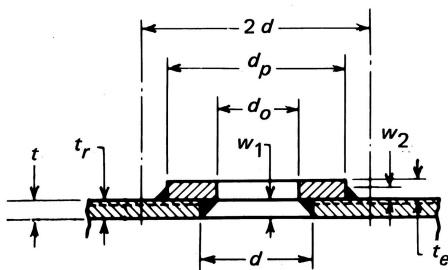
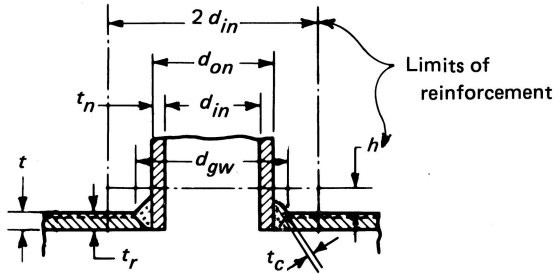

Figure D-101
Computation of a Typical Nozzle Fitting



$\frac{7}{16}$ in., and a working pressure of 160 psi. The shell material is in accordance with SA-285 Grade C.

(b) *Wall Thickness Required* (See HG-301)

$$t_r = \frac{PR}{SE - 0.6P}$$

$$= \frac{160 \times 18}{11,000 \times 1.0 - 0.6 \times 160} = 0.264 \text{ in.}$$

(c) *Nozzle Thickness Required*

$$t_{rn} = \frac{PR}{SE - 0.6P}$$

$$= \frac{160 \times 1.913}{9,600 \times 1.0 - 0.6 \times 160} = 0.032 \text{ in.}$$

(d) *Size Weld Required* (See HW-731)

$$t_c = t_{\min} \times 0.7$$

$$= 0.337 \times 0.7 = 0.236 \text{ in.}$$

(e) *Area of Reinforcement Required* (See HG-321)

$$A = dt_r F + 2t_n t_r F \left(1 - \frac{S_n}{S_v}\right)$$

$$= 3.826 \times 0.264 \times 1.0$$

$$+ 2(0.337)(0.264)(1.0) \left(1 - \frac{9,600}{11,000}\right)$$

$$= 1.033 \text{ in.}^2$$

(f) *Area of Reinforcement Provided* (See HG-326)

$$A_1 = (E_1 t - Ft_r) d - 2t_n (Et - Ft_r) \left(1 - \frac{S_n}{S_v}\right)$$

$$= (1.0 \times 0.438 - 1.0 \times 0.264) 3.826$$

$$- 2.0 \times 0.337 (1.0 \times 0.438 - 1.0 \times 0.264)$$

$$\times (0.127)$$

$$= 0.651 \text{ in.}^2$$

$$A_2 = (t_n - t_{rn})(5t_n + 2t_e) \left(\frac{S_n}{S_v}\right)$$

$$= (0.337 - 0.032)(5.0 \times 0.337 + 2.0 \times 0)(0.873)$$

$$= 0.449 \text{ in.}^2$$

$$A_3 = \text{leg}^2$$

$$= 0.337 \times 0.337 = \underline{0.114 \text{ in.}^2}$$

$$A_T = \text{total reinforcement} = 1.214 \text{ in.}^2$$

$A_T > A$ (opening is reinforced)

(g) *Load to Be Carried by the Welds* (see HG-327.2)

$$W = [(d_{on} \times t_r) - (2d_{in} - d_{on})(t - t_r)] S(\text{shell})$$

$$= [(4.50 \times 0.264) - (2.0 \times 3.826 - 4.50)$$

$$\times (0.437 - 0.264)] 11,000$$

$$= 7,035 \text{ lb}$$

(h) *Unit Stresses* (See HW-730.2)

$$\text{Shear in fillet weld} = 0.49 \times 11,000$$

$$= 5,390 \text{ psi} = S_s$$

$$\text{Tension in groove weld} = 0.74 \times 11,000$$

$$= 8,140 \text{ psi} = S_t$$

$$\text{Shear in nozzle wall} = 0.70 \times 11,000$$

$$= 7,700 \text{ psi} = S_n$$

(i) *Strength of Connection Elements* (See HW-730.1)

(1) *Fillet Weld in Shear*

$$\frac{\pi}{2} \times d_{on} \times \text{weld leg} \times S_s = 1.57 \times 4.5 \times 0.337 \times 5,390$$

$$= 12,833 \text{ lb}$$

(2) Groove Weld in Tension

$$\begin{aligned} \frac{\pi}{2} \times d_{on} \times t \times S_t &= 1.57 \times 4.5 \times 0.437 \times 8,140 \\ &= 25,100 \text{ lb} \end{aligned}$$

(3) Nozzle Wall Shear

$$\begin{aligned} \frac{\pi}{2} \times \text{mean nozzle diam.} \times t_n \times S_n \\ &= 1.571 \times 4.163 \times 0.337 \times 7,700 \\ &= 16,971 \text{ lb} \end{aligned}$$

Possible paths of failure are

(-a) through (1) and (2) above with a strength of 37,933 lb

(-b) through (1) and (3) above with a strength of 29,804 lb

Both paths are stronger than the required strength of 7,035 lb.

NONMANDATORY APPENDIX E TERMINOLOGY

(23) E-100 TERMS RELATING TO CERTIFICATION

Data Report, Manufacturer's: a properly completed and certified document, in hard copy or electronic form, using the H-2, H-3 or HLW-6 Manufacturer's Data Report Form that documents the construction of a pressure vessel of wrought materials or series of identical pressure vessels of wrought materials as defined in this Code.

Data Report, Manufacturer's Master:

(a) a properly completed and certified document, in hard copy or electronic form, using the H-2, H-3 or HLW-6 Manufacturer's Data Report Form with the Manufacturer's Master Data Report "YES" checkbox checked that summarizes the construction of a pressure vessel of wrought materials or series of identical pressure vessels of wrought materials having more than one associated Manufacturer's Data Report as defined in this Code.

(b) a properly completed and certified document, in hard copy or electronic form, using the H-5 or H-5A Manufacturer's Data Report Form that records the design pressure test results of a boiler or boiler parts made from cast iron or cast aluminum as defined in this Code.

Data Report, Manufacturer's Modular Master: a properly completed and certified document, in hard copy or electronic form, using the H-1 Manufacturer's Modular Master Data Report Form that summarizes specific information for each module including the applicable associated manufacturer's data reports related to the individual boiler or water heater modules.

Data Report, Manufacturer's Partial: a properly completed and certified document, in hard copy or electronic form, using the H-4 or HLW-7 Manufacturer's Partial Data Report Form that documents all parts that require inspection under this Code that are fabricated by a manufacturer other than the manufacturer of a completed boiler or water heater constructed of wrought materials.

Form, Manufacturer's Data Report: a hard copy or electronic form used to generate one of the types of Manufacturer's Data Reports per the requirements of this Code.

E-101 TERMS RELATING TO DESIGN

(23)

boiler, automatically fired: a boiler equipped with a means of introducing heat or of causing fuel, whether solid, liquid, gaseous, or electric, to be introduced into the boiler or boiler furnace, the means being so regulated by the rate of flow, the generating pressure, or temperature of the boiler fluid or of a vessel or space being heated as to maintain a determined, desired condition within a designated tolerance.

boiler, electric, resistance heating element type: electric boilers of the resistance heating element type are either:

(a) of a design where the electric resistance element is directly attached to the external surface of the pressure vessel; or

(b) an immersed type where the electric resistance element is inserted through an opening in the pressure vessel so that the element is in direct contact with the water.

boiler, horizontal-return tubular: a firetube boiler consisting of a cylindrical shell, with tubes inside the shell attached to both end closures. The products of combustion pass under the bottom half of the shell and return through the tubes.

boiler, hot water heating: a boiler designed to heat water for circulation through an external space heating system.

boiler, hot water supply: a boiler used to heat water for purposes other than space heating.

boiler, modular: a steam or hot-water heating assembly consisting of a grouping of individual boilers or individually fired sections called modules, intended to be installed and operated as a unit, with no intervening stop valves between the modules, with a single inlet and a single outlet. Modules may be under one jacket or may be individually jacketed.

boiler, steam heating: a boiler designed to convert water into steam that is supplied to an external space heating system.

boiler, vacuum: a factory-sealed steam boiler that is operated below atmospheric pressure.

bottom blowoff valve: a valve or cock located in the bottom blowoff connection of a boiler that, when opened, permits free passage of scale and sediment during the blowoff operation.

column, fluid relief: that piping, connected to the top of a hot water heating boiler, which is provided for the thermal expansion of the water. It will connect to either an open or a closed expansion tank.

drain valve: a valve or cock located in a boiler connection that, when opened, will drain the lowest water space practicable.

electric boiler, submerged electrode type: a submerged electrode type electric boiler incorporates a design wherein two or more metallic electrodes are directly suspended in the boiler water. When a source of electric power is connected to the electrodes, current will flow between the electrodes and through the water, thus raising the temperature of the water to produce steam.

feedwater: water introduced into a boiler during operation. Feedwater includes makeup and return condensate or return water.

flue: passage through which gases pass from the combustion chamber or furnace to the venting system.

furnace: that part of a boiler in which combustion of fuel takes place or in which primary furnace gases are conveyed.

gases, primary furnace: gases in a zone where the anticipated temperature of the gas exceeds 850°F (450°C).

joints, swing: threaded, flanged, welded, or brazed pipe and fittings so arranged that the piping system that they comprise, when connected to a boiler, can expand and contract without imposing excessive force on it.

makeup water: water introduced into the boiler to replace that lost or removed from the system.

pressure, design: the pressure used in the design of a boiler for the purpose of calculating the minimum permissible thickness or physical characteristics of the different parts of the boiler.

pressure, maximum allowable working: the maximum gage pressure permissible in a completed boiler. The MAWP of the completed boiler shall be less than or equal to the lowest design pressure determined for any of its parts. This pressure is based upon either proof tests or calculations for every pressure part of the boiler using nominal thickness exclusive of allowances for corrosion and thickness required for loadings other than pressure.

pressure, operating: the pressure of a boiler at which it normally operates. It shall not exceed the maximum allowable working pressure and it is usually kept at a suitable level below the setting of the pressure-relieving devices to prevent their frequent opening.

siphon: a bent pipe or tube, between a steam pressure gage and the steam connection on a boiler, so fabricated that it contains a water seal that prevents steam entering the Bourdon tube of the gage.

stress, maximum allowable: the maximum unit stress permitted in a given material used under these rules.

surface, heating, square feet of: that area of the boiler surface exposed to the products of combustion. In computing the heating surface for the purpose of determining the pressure relief valve requirements, only the tubes, fireboxes, shells, tubesheets, and the projected area of the headers need be considered, except that for vertical firetube boilers only that portion of the tube surface up to the middle point of the gage glass is to be computed.

thickness, required: the minimum thickness determined by the formulas in this Code.

tube, fire: a hollow cylinder used for the conveyance of gases, flame, or hot air.

tube, water: a hollow cylinder used for the conveyance of liquids.

valve, relief: a spring-loaded pressure relief valve actuated by the static pressure upstream of the valve. The valve opens normally in proportion to the pressure increase over the opening pressure. A relief valve is used primarily with incompressible fluids.

valve, safety: a pressure relief valve characterized by rapid opening (i.e., popping) and normally used to relieve compressible fluids (i.e., gas or vapor).

valve, safety relief: a pressure relief valve characterized by rapid opening (i.e., popping) or by gradual opening that is generally proportional to the increase in pressure. It can be used for compressible or incompressible fluids.

valve, temperature and pressure relief: a pressure relief valve that may be actuated by pressure at the valve inlet or by temperature at the valve inlet.

water heater: a vessel in which potable water is heated by the combustion of fuel, by electricity, or by any other source, and withdrawn for external use.

water heater, lined: a water heater with a corrosion resistant lining designed to heat potable water.

water heater, modular: a water heater assembly consisting of a grouping of individual water heaters called modules, intended to be installed and operated as a unit with no intervening stop valves between the modules, with a single inlet and a single outlet. Modules may be under one jacket or may be individually jacketed.

water heater, unlined: a water heater made from corrosion resistant materials designed to heat potable water.

water temperature, maximum: the maximum water temperature permissible in a completed boiler or water heater.

wet-bottom boiler: any type of boiler that has a stayed or self-supporting, partially or fully water-cooled, shell or furnace bottom.

E-102 TERMS RELATING TO WELDING

arc stud welding: an arc welding process wherein coalescence is produced by heating with an arc drawn between a metal stud, or similar part, until the surfaces to be joined are properly heated, when they are brought together under pressure. Partial shielding may be obtained by the use of a ceramic ferrule surrounding the stud. Shielding gas or flux may or may not be used.

arc welding: a group of welding processes wherein coalescence is produced by heating with an electric arc or arcs, with or without the application of pressure and with or without the use of filler metal.

atomic hydrogen welding: an arc welding process wherein coalescence is produced by heating with an electric arc maintained between two metal electrodes in an atmosphere of hydrogen. Shielding is obtained from the hydrogen. Pressure may or may not be used and filler metal may or may not be used.

automatic welding: welding with equipment that performs the entire welding operation without constant observation and adjustment of the controls by an operator. The equipment may or may not perform the loading and unloading of the work.

backing: material (metal, weld metal, asbestos, carbon, granular flux, etc.) backing up the joint during welding to facilitate obtaining a sound weld at the root.

base metal: the metal to be welded or cut.

brazing: a group of metal-joining processes wherein coalescence is produced by heating to suitable temperatures above 800°F (425°C) and by using a nonferrous filler metal, having a melting point below that of the base metals. The filler metal is distributed between the closely fitted surfaces of the joint by capillary attraction.

butt joint: a joint between two members lying approximately in the same plane.

corner joint: a joint between two members located approximately at right angles to each other in the form of an L.

double-welded butt joint: a butt joint welded from both sides.

double-welded lap joint: a lap joint in which the overlapped edges of the members to be joined are welded along the edges of both members.

edge joint: a joint between the edges of two or more parallel or nearly parallel members.

filler metal: metal to be added in making a weld.

fillet weld: a weld of approximately triangular cross section joining two surfaces approximately at right angles to each other in a lap joint, tee joint, or corner joint.

flux cored arc welding (FCAW): a gas metal arc welding process that produces coalescence of metals by heating them with an arc between a continuous filler metal (consumable) electrode and the work. Shielding is provided by a flux contained within the tubular electrode. Additional shielding may or may not be obtained from an externally supplied gas or gas mixture.

flux cored arc welding-electrode (FCAW-EG): a variation of the flux cored arc welding process in which molding shoes are used to confine the molten weld metal for vertical position welding. Additional shielding may or may not be obtained from an externally supplied gas or gas mixture.

flux cored electrode: a composite filler metal electrode consisting of a metal tube or other hollow configuration containing ingredients to provide such functions as shielding atmosphere, deoxidation, arc stabilization, and slag formation. Alloying materials may be included in the core. External shielding may or may not be used.

full fillet weld: a fillet weld whose size is equal to the thickness of the thinner member joined.

gas metal arc welding-electrode (GMAW-EG): a variation of the gas metal arc welding process using molding shoes to confine the molten weld metal for vertical position welding.

gas tungsten-arc welding: an arc welding process wherein coalescence is produced by heating with an electric arc between a single tungsten (nonconsumable) electrode and the work. Shielding is obtained from a gas or gas mixture (which may contain an inert gas). Pressure may or may not be used. Filler metal may or may not be used. (This process has sometimes been called TIG Welding.)

gas welding: a group of welding processes wherein coalescence is produced by heating with a gas flame or flames with or without the application of pressure, and with or without the use of filler metal.

joint efficiency: the efficiency of a welded joint is expressed as a numerical (decimal) quantity and is used in the design of a joint as a multiplier of the appropriate allowable stress taken from Section II, Part D, Table 6A or Table 6B.

joint penetration: the minimum depth a groove weld extends from its face into a joint, exclusive of reinforcement.

lap joint: a joint between two overlapping members.

machine welding: welding with equipment that performs the welding operation under the observation and control of an operator. The equipment may or may not perform the loading and unloading of the work.

manual welding: welding wherein the entire welding operation is performed and controlled by hand.

oxyacetylene welding: a gas welding process wherein coalescence is produced by heating with a gas flame or flames obtained from the combustion of acetylene with oxygen, with or without the application of pressure and with or without the use of filler metal.

oxygen cutting: a group of cutting processes wherein the severing of metals is affected by means of the chemical reaction of oxygen with the base metal at elevated temperatures. In the case of oxidation resistant metals, the reaction is facilitated by use of a flux or metal powder.

oxyhydrogen welding: a gas welding process wherein coalescence is produced by heating with a gas flame or flames obtained from the combustion of hydrogen with oxygen, without the application of pressure and with or without the use of filler metal.

plasma arc welding: a gas tungsten arc welding process wherein coalescence is produced by heating with a constricted arc between an electrode and workpiece (transferred arc) or the electrode and the constricting nozzle (nontransferred arc). Shielding is obtained from hot ionized gas issuing from the orifice that may be supplemented by an auxiliary source of shielding gas. Shielding gas may be an inert gas or a mixture of gases, pressure may or may not be used, and filler metal may or may not be used.

pressure gas welding: a gas welding process wherein coalescence is produced simultaneously over the entire area of abutting surfaces, by heating with a gas flame or flames obtained from combustion of hydrogen with oxygen, without the application of pressure, and with or without the use of filler metal.

pressure welding: any welding process or method wherein pressure is used to complete the weld.

projection welding (PW): a resistance welding process that produces coalescence by the heat obtained from the resistance of the flow of welding current. The resulting welds are localized at predetermined points by projections, embossments, or intersections. The metals to be joined lap over each other.

reinforcement of weld: weld metal on the face of a groove weld in excess of the metal necessary for the specified weld size.

resistance seam welding (RSEW): a resistance welding process that produces coalescence of overlapped parts at the faying surfaces progressively along the length of a joint. The weld may be made with overlapping nuggets, a continuous weld nugget, or by forging the joint as it is heated to the welding temperature by resistance to the flow of welding current.

resistance spot welding (RSW): a resistance welding process that produces coalescence at the faying surfaces of overlapped parts by the heat obtained from resistance of the work to the flow of welding current in a circuit of

which the work is a part, and by the application of pressure.

resistance stud welding: a resistance welding process wherein coalescence is produced by the heat obtained from resistance to electric current at the interface between the stud and the work piece, until the surfaces to be joined are properly heated, when they are brought together under pressure.

resistance welding (RW): a group of welding processes that produces coalescence of overlapping faying surfaces with the heat obtained from resistance of the work to the flow of current in a circuit of which the work is a part, and by the application of pressure.

seal weld: any weld used primarily to obtain tightness.

semiautomatic arc welding: arc welding with equipment that controls only the filler metal feed. The advance of the welding is manually controlled.

shielded metal-arc welding: an arc welding process wherein coalescence is produced by heating with an electric arc between a covered metal electrode and the work. Shielding is obtained from decomposition of the electrode covering. Pressure is not used and filler metal is obtained from the electrode.

single-welded butt joints: a butt joint welded from one side only.

single-welded lap joint: a lap joint in which the overlapped edges of the members to be joined are welded along the edge of one member.

size of equal-leg fillet welds: the leg length of the largest isosceles right triangle that can be inscribed within the fillet weld cross section.

size of groove weld: the joint penetration (depth of chamfering plus the root penetration when specified).

size of unequal-leg fillet welds: the leg lengths of the largest right triangle that can be inscribed within the fillet weld cross section.

submerged arc welding: an arc welding process wherein coalescence is produced by heating with an electric arc or arcs between a bare metal electrode or electrodes and the work. The welding is shielded by a blanket of granular, fusible material on the work. Pressure is not used and filler metal is obtained from the electrode and sometimes from a supplementary welding rod.

tee joint: a joint between two members located approximately at right angles to each other in the form of a T.

thermit welding: a group of welding processes wherein coalescence is produced by heating with superheated liquid metal and slag resulting from a chemical reaction between a metal oxide and aluminum, with or without the application of pressure. Filler metal, when used, is obtained from the liquid metal.

throat of a fillet weld, actual: the shortest distance from the root of a fillet weld to its face.

throat of a fillet weld, theoretical: the distance from the beginning of the root of the joint perpendicular to the hypotenuse of the largest right triangle that can be inscribed within the fillet weld cross section.

undercut: a groove melted into the base metal adjacent to the toe of a weld and left unfilled by weld metal.

weld: a localized coalescence of metal wherein coalescence is produced by heating to suitable temperatures, with or without the application of pressure and with or without

the use of filler metal. The filler metal has a melting point approximately the same as the base metals.

weld metal: that portion of a weld that has been melted during welding.

welded joint: a union of two or more members produced by the application of a welding process.

welder: one who is capable of performing a manual or semiautomatic welding operation.

welding operator: one who operates machine or automatic welding equipment.

NONMANDATORY APPENDIX F QUALITY CONTROL SYSTEM

F-100 GENERAL

F-100.1 Quality Control System. The manufacturer or assembler shall have and maintain a quality control system that will establish that all Code requirements including material, design, fabrication, examination (by the manufacturer), and inspection (by the Authorized Inspector) for boilers and water heaters constructed primarily of wrought materials will be met.

Provided that Code requirements are suitably identified, the system may include provisions for satisfying any requirements by the manufacturer or user that exceed minimum Code requirements and may include provisions for quality control of non-Code work. In such systems, the manufacturer may make changes in parts of the system that do not affect the Code requirements without securing acceptance by the Authorized Inspector.

The system that the manufacturer uses to meet the requirements of this Section must be one suitable for his own circumstances. The necessary scope and detail of the system shall depend upon the complexity of the work performed and upon the size and complexity of the manufacturer's organization. A written description of the system the manufacturer will use to produce a Code item shall be available for review. Depending upon the circumstances, the description may be brief or voluminous.

The written description may contain information of a proprietary nature relating to the manufacturer's processes. Therefore, the Code does not require any distribution of this information, except for the Authorized Inspector or ASME Designee, as covered by [F-202.10](#). It is intended that information learned about the quality control system in connection with evaluation will be treated as confidential and that all loaned descriptions will be returned to the manufacturer upon completion of the evaluation.

F-202 OUTLINE OF FEATURES TO BE INCLUDED IN THE WRITTEN DESCRIPTION OF THE QUALITY CONTROL SYSTEM

The following is a guide to some of the features that should be covered in the written description of the quality control system and that is equally applicable to both shop and field work.

F-202.1 Authority and Responsibility. The authority and responsibility of those in charge of the quality control system shall be clearly established. Persons performing quality control functions shall have sufficient and well defined responsibility, the authority, and the organizational freedom to identify quality control problems and to initiate, recommend, and provide solutions.

F-202.2 Organization. An organization chart showing the relationship between management and engineering, purchasing, manufacturing, field assembling, inspection, and quality control, is required to reflect the actual organization. The purpose of this chart is to identify and associate the various organizational groups with the particular function for which they are responsible. The Code does not intend to encroach on the manufacturer's right to establish, and from time to time, alter whatever form of organization the manufacturer considers appropriate for its Code work.

F-202.3 Drawings, Design Calculations, and Specification Control. The manufacturer's or assembler's quality control system shall provide procedures that will insure that the latest applicable drawings, design calculations, specifications, and instructions required by the Code, as well as authorized changes, are used for manufacture, assembly, examination, inspection, and testing.

F-202.4 Material Control. The Manufacturer or assembler shall include a system of receiving control that requires verification that the material received conforms to order requirements and that the identification of the materials corresponds to the material certifications or material test reports. The system shall ensure that only the intended material is used in Code construction.

F-202.5 Examination and Inspection Program.

The Manufacturer's quality control system shall describe the fabrication operations, including examinations, sufficiently to permit the Authorized Inspector to determine at what stages specific inspections are to be performed.

F-202.6 Correction of Nonconformities. There shall be a system agreed upon with the Authorized Inspector for correction of nonconformities. A nonconformity condition is a condition that does not comply with the applicable rules of this Section. Nonconformities must be corrected or eliminated in some way before the completed component can be considered to comply with this Section.

F-202.7 Welding or Brazing. The quality control system shall include provisions for indicating that welding or brazing conforms to requirements of Section IX as supplemented by this Section.

F-202.8 Calibration of Measurement and Test Equipment. The Manufacturer or assembler shall have a system for the calibration of examination, measuring, and testing of equipment used in fulfillment of requirements of this Section.

F-202.9 Sample Forms. The forms used in the quality control system and any detailed procedures for their use shall be available for review. The written description shall make necessary references to these forms.

F-202.10 Authorized Inspector.

F-202.10.1 The Authorized Inspector is the ASME Code Inspector defined in [HG-515.3](#).

F-202.10.2 The written description of the quality control system shall include reference to the Authorized Inspector.

F-202.10.2.1 The Manufacturer shall make available to the Authorized Inspector at the Manufacturer's plant a copy of the written description of the quality control system.

F-202.10.2.2 The Manufacturer's quality control system shall provide for the Authorized Inspector at the Manufacturer's plant to have access to all drawings, calculations, specifications, procedures, process sheets, repair procedures, records, test results, and any other documents as necessary for the Authorized Inspector to perform his duties in accordance with this Section. The Manufacturer may provide such access either to his own files of such documents or by providing copies to the Authorized Inspector.

F-202.11 Certifications. Methods other than written signature may be used for indicating certifications, authorizations, and approval where allowed and as described elsewhere in this section. Where other methods are employed, controls and safeguards shall be provided and described to ensure the integrity of the certification, authorization, and approval.

NONMANDATORY APPENDIX H LIST OF ABBREVIATIONS AND ADDRESSES

(23)

ANSI = American National Standards Institute 25 West 43rd Street, New York, NY 10036	NEC = National Electric Code NFPA 70 National Fire Protection Association International 1 Batterymarch Park, Quincy, MA 02169
ASHRAE = American Society of Heating, Refrigerating and Air Conditioning Engineers 180 Technology Parkway NW, Peachtree Corners, GA 30092	NSFI = National Sanitation Foundation International 789 North Dixboro Road, Ann Arbor, MI 48105
ASTM = American Society for Testing and Materials 100 Barr Harbor Drive, West Conshohocken, PA 19428	UL = Underwriters Laboratories, Inc. 333 Pfingsten Road, Northbrook, IL 60062
CSA = CSA International 178 Rexdale Boulevard, Toronto, Ontario, Canada M9W 1R3; 8501 East Pleasant Valley Road, Cleveland, OH 44131	

NONMANDATORY APPENDIX K

GUIDE TO INFORMATION APPEARING ON CERTIFICATE OF AUTHORIZATION

(23)

Reference to Circled Numbers in Figure K-1	Description
(1)	Certification Mark granted by the Society, i.e., H Heating Boilers and HLW Water Heaters.
(2)	<ul style="list-style-type: none"> a. The name of the Manufacturer or Assembler. b. The full street address, city, state or province, country, and zip code.
(3)	<p>This section describes the scope and limitations, if any, on use of the Certification Mark and designators, as illustrated below by some examples of scope statements. Field site Certificate of Authorization applies to items that are fabricated or assembled at a field site and is not intended to apply to items at any shop location.</p> <p>Certification Mark With H Designator</p> <ul style="list-style-type: none"> - Heating boilers, except cast iron and cast aluminum, at the above location only. - Heating boilers, except cast iron and cast aluminum, at the above location only. (This authorization includes multiple duplicate heating boilers.) - Heating boilers, except cast iron and cast aluminum, at the above location. (This authorization does not cover welding or brazing.) - Heating boilers, except cast iron and cast aluminum, at the above location and field sites controlled by the above location. - Heating boilers, cast iron only, at the above location only. (Assembly) - Heating boilers, except cast iron and cast aluminum at field sites controlled by the above location only. - Heating boilers, except cast iron and cast aluminum, at the above location only. (This authorization includes multiple duplicate heating boilers and does not include welding or brazing.) - Heating boilers, cast iron only, at the above location only. (Foundry) - Heating boilers, cast iron only, at the above location only. (Foundry and Assembly) - Heating boilers, cast iron only, at the above location only. (Installation of nameplate only, does not include assembly and hydrostatic test.) - Heating boilers, cast aluminum only, at the above location only. (Assembly) - Heating boilers, cast aluminum only, at the above location only. (Foundry) - Heating boilers, cast aluminum only, at the above location only. (Foundry and Assembly) - Heating boilers, cast aluminum only, at the above location only. (Installation of nameplate only, does not include assembly and hydrostatic test) <p>Certification Mark With HLW Designator</p> <ul style="list-style-type: none"> - Potable water heaters at the above location only. - Potable water heaters at the above location only. (This authorization includes multiple duplicate potable water heaters.) - Potable water heaters at the above location and field sites controlled by the above location. - Potable water heaters at the above location only. (This authorization does not cover welding or brazing.) - Potable water storage tanks at the above location only. - Potable water storage tanks at the above location only (This authorization includes multiple duplicate potable water storage tanks.) - Potable water storage tanks at the above location and field sites controlled by the above location. - Potable water storage tanks at the above location only. (This authorization does not cover welding or brazing.) - Potable water heaters and potable water storage tanks at the above location only. - Potable water heaters and potable water storage tanks at the above location only. (This authorization includes multiple duplicate potable water heaters and potable water storage tanks.)

Reference to Circled Numbers in Figure K-1	Description
	<p>Certification Mark With HLW Designator (Cont'd)</p> <ul style="list-style-type: none"> - Potable water heaters and potable water storage tanks at the above location and field sites controlled by the above location. - Potable water heaters and potable water storage tanks at the above location only. (This authorization does not cover welding or brazing.) <p>Certification Mark With PRT IV Designator [Note (1)]</p> <ul style="list-style-type: none"> - Manufacture and assembly of parts without design responsibility at the above location only. - Manufacture and assembly of parts without design responsibility at the above location and field sites controlled by the above location.
(4)	The date authorization was granted by the Society to use the appropriate Certification Mark.
(5)	The date authorization to use the appropriate Certification Mark will expire.
(6)	A unique Certificate number assigned by the Society.
(7), (8)	The signatures of the current chair and managing director.

NOTE: (1) Scope statements for PRT Certificates of Authorization may include other ASME Boiler and Pressure Vessel Code Sections consistent with qualification in accordance with those Code sections.

**Figure K-1
Sample Certificate of Authorization**

CERTIFICATE OF AUTHORIZATION

CERTIFICATION MARK ①

The named company is authorized by The American Society of Mechanical Engineers (ASME) for the scope of activity shown below in accordance with the applicable rules of the ASME Boiler and Pressure Vessel Code. The use of the Certification Mark and the authority granted by this Certificate of Authorization are subject to the provisions of the agreement set forth in the application. Any construction stamped with this Certification Mark shall have been built strictly in accordance with the provisions of the ASME Boiler and Pressure Vessel Code.

COMPANY: ②

SCOPE: ③

AUTHORIZED: ④

EXPIRES: ⑤

CERTIFICATE NUMBER: ⑥

⑦

CHAIR, BOARD ON CONFORMITY ASSESSMENT

⑧

MANAGING DIRECTOR, CONFORMITY ASSESSMENT

The American Society of Mechanical Engineers



NONMANDATORY APPENDIX M

GUIDANCE FOR THE USE OF U.S. CUSTOMARY AND SI UNITS IN THE ASME BOILER AND PRESSURE VESSEL CODE

M-100 USE OF UNITS IN EQUATIONS

The equations in this Section are suitable for use with either the U.S. Customary or the SI units provided in [Mandatory Appendix 6](#), or with the units provided in the nomenclatures associated with the equations. It is the responsibility of the individual and organization performing the calculations to ensure that appropriate units are used. Either U.S. Customary or SI units may be used as a consistent set. When necessary to convert from one system of units to another, the units shall be converted to at least three significant figures for use in calculations and other aspects of construction.

M-200 GUIDELINES USED TO DEVELOP SI EQUIVALENTS

The following guidelines were used to develop SI equivalents:

(a) SI units are placed in parentheses after the U.S. Customary units in the text.

(b) In general, separate SI tables are provided if interpolation is expected. The table designation (e.g., table number) is the same for both the U.S. Customary and SI tables, with the addition of suffix “M” to the designator for the SI table, if a separate table is provided. In the text, references to a table use only the primary table number (i.e., without the “M”). For some small tables, where interpolation is not required, SI units are placed in parentheses after the U.S. Customary unit.

(c) Separate SI versions of graphical information (charts) are provided, except that if both axes are dimensionless, a single figure (chart) is used.

(d) In most cases, conversions of units in the text were done using hard SI conversion practices, with some soft conversions on a case-by-case basis, as appropriate. This was implemented by rounding the SI values to the number of significant figures of implied precision in the existing U.S. Customary units. For example, 3,000 psi has an implied precision of one significant figure. Therefore, the conversion to SI units would typically be to 20 000 kPa. This is a difference of about 3% from the “exact” or soft conversion of 20 684.27 kPa. However, the precision of the conversion was determined by the Committee on a case-by-case basis. More significant digits were

included in the SI equivalent if there was any question. The values of allowable stress in Section II, Part D generally include three significant figures.

(e) Minimum thickness and radius values that are expressed in fractions of an inch were generally converted according to the following table:

Fraction, in.	Proposed SI Conversion, mm	Difference, %
$\frac{1}{32}$	0.8	-0.8
$\frac{3}{64}$	1.2	-0.8
$\frac{1}{16}$	1.5	5.5
$\frac{3}{32}$	2.5	-5.0
$\frac{1}{8}$	3	5.5
$\frac{5}{32}$	4	-0.8
$\frac{3}{16}$	5	-5.0
$\frac{7}{32}$	5.5	1.0
$\frac{1}{4}$	6	5.5
$\frac{5}{16}$	8	-0.8
$\frac{3}{8}$	10	-5.0
$\frac{7}{16}$	11	1.0
$\frac{1}{2}$	13	-2.4
$\frac{9}{16}$	14	2.0
$\frac{5}{8}$	16	-0.8
$\frac{11}{16}$	17	2.6
$\frac{3}{4}$	19	0.3
$\frac{7}{8}$	22	1.0
1	25	1.6

(f) For nominal sizes that are in even increments of inches, even multiples of 25 mm were generally used. Intermediate values were interpolated rather than converting and rounding to the nearest mm. See examples in the following table. [Note that this table does not apply to nominal pipe sizes (NPS), which are covered below.]

Size, in.	Size, mm
1	25
$1\frac{1}{8}$	29
$1\frac{1}{4}$	32
$1\frac{1}{2}$	38
2	50
$2\frac{1}{4}$	57

Table continued

Size, in.	Size, mm
2½	64
3	75
3½	89
4	100
4½	114
5	125
6	150
8	200
12	300
18	450
20	500
24	600
36	900
40	1000
54	1350
60	1500
72	1800

Size or Length, ft	Size or Length, m
3	1
5	1.5
200	60

(g) For nominal pipe sizes, the following relationships were used:

U.S. Customary Practice		U.S. Customary Practice	
SI Practice	SI Practice	SI Practice	SI Practice
NPS ½	DN 6	NPS 20	DN 500
NPS ¾	DN 8	NPS 22	DN 550
NPS ¾	DN 10	NPS 24	DN 600
NPS 1½	DN 15	NPS 26	DN 650
NPS ¾	DN 20	NPS 28	DN 700
NPS 1	DN 25	NPS 30	DN 750
NPS 1¼	DN 32	NPS 32	DN 800
NPS 1½	DN 40	NPS 34	DN 850
NPS 2	DN 50	NPS 36	DN 900
NPS 2½	DN 65	NPS 38	DN 950
NPS 3	DN 80	NPS 40	DN 1000
NPS 3½	DN 90	NPS 42	DN 1050
NPS 4	DN 100	NPS 44	DN 1100
NPS 5	DN 125	NPS 46	DN 1150
NPS 6	DN 150	NPS 48	DN 1200
NPS 8	DN 200	NPS 50	DN 1250
NPS 10	DN 250	NPS 52	DN 1300
NPS 12	DN 300	NPS 54	DN 1350
NPS 14	DN 350	NPS 56	DN 1400
NPS 16	DN 400	NPS 58	DN 1450
NPS 18	DN 450	NPS 60	DN 1500

(h) Areas in square inches (in.²) were converted to square millimeters (mm²), and areas in square feet (ft²) were converted to square meters (m²). See examples in the following table:

Area (U.S. Customary)	Area (SI)
1 in. ²	650 mm ²
6 in. ²	4000 mm ²
10 in. ²	6500 mm ²
5 ft ²	0.5 m ²

(i) Volumes in cubic inches (in.³) were converted to cubic millimeters (mm³), and volumes in cubic feet (ft³) were converted to cubic meters (m³). See examples in the following table:

Volume (U.S. Customary)	Volume (SI)
1 in. ³	16 000 mm ³
6 in. ³	100 000 mm ³
10 in. ³	160 000 mm ³
5 ft ³	0.14 m ³

(j) Although the pressure should always be in MPa for calculations, there are cases where other units are used in the text. For example, kPa is used for small pressures. Also, rounding was to one significant figure (two at the most) in most cases. See examples in the following table. (Note that 14.7 psi converts to 101 kPa, while 15 psi converts to 100 kPa. While this may seem at first glance to be an anomaly, it is consistent with the rounding philosophy.)

Pressure (U.S. Customary)	Pressure (SI)
0.5 psi	3 kPa
2 psi	15 kPa
3 psi	20 kPa
10 psi	70 kPa
14.7 psi	101 kPa
15 psi	100 kPa
30 psi	200 kPa
50 psi	350 kPa
100 psi	700 kPa
150 psi	1 MPa
200 psi	1.5 MPa
250 psi	1.7 MPa
300 psi	2 MPa
350 psi	2.5 MPa
400 psi	3 MPa
500 psi	3.5 MPa
600 psi	4 MPa
1,200 psi	8 MPa
1,500 psi	10 MPa

(k) Material properties that are expressed in psi or ksi (e.g., allowable stress, yield and tensile strength, elastic modulus) were generally converted to MPa to three significant figures. See example in the following table:

Strength (U.S. Customary)	Strength (SI)
95,000 psi	655 MPa

(l) In most cases, temperatures (e.g., for PWHT) were rounded to the nearest 5°C. Depending on the implied precision of the temperature, some were rounded to the nearest 1°C or 10°C or even 25°C. Temperatures colder than 0°F (negative values) were generally rounded to the nearest 1°C. The examples in the table below were created by rounding to the nearest 5°C, with one exception:

Temperature, °F	Temperature, °C
70	20
100	38
120	50
150	65
200	95
250	120
300	150
350	175
400	205
450	230
500	260
550	290
600	315
650	345
700	370
750	400
800	425
850	455
900	480
925	495
950	510
1,000	540
1,050	565
1,100	595
1,150	620
1,200	650
1,250	675
1,800	980
1,900	1040
2,000	1095

Table continued

Temperature, °F	Temperature, °C
2,050	1120

M-300 SOFT CONVERSION FACTORS

The following table of “soft” conversion factors is provided for convenience. Multiply the U.S. Customary value by the factor given to obtain the SI value. Similarly, divide the SI value by the factor given to obtain the U.S. Customary value. In most cases it is appropriate to round the answer to three significant figures.

U.S. Customary	SI	Factor	Notes
in.	mm	25.4	...
ft	m	0.3048	...
in. ²	mm ²	645.16	...
ft ²	m ²	0.09290304	...
in. ³	mm ³	16,387.064	...
ft ³	m ³	0.02831685	...
U.S. gal	m ³	0.003785412	...
U.S. gal	liters	3.785412	...
psi	MPa (N/mm ²)	0.0068948	Used exclusively in equations
psi	kPa	6.894757	Used only in text and for nameplate
psi	bar	0.06894757	...
ft-lb	J	1.355818	...
°F	°C	$\frac{5}{9} \times (°F - 32)$	Not for temperature difference
°F	°C	$\frac{5}{9}$	For temperature differences only
°R	K	$\frac{5}{9}$	Absolute temperature
lbm	kg	0.4535924	...
lbf	N	4.448222	...
in.-lb	N·mm	112.98484	Use exclusively in equations
ft-lb	N·m	1.3558181	Use only in text
ksi√in.	MPa√m	1.0988434	...
Btu/hr	W	0.2930711	Use for boiler rating and heat transfer
lb/ft ³	kg/m ³	16.018463	...

NONMANDATORY APPENDIX N GUIDE TO MANUFACTURER'S CERTIFICATE OF CONFORMANCE FOR PRESSURE RELIEF VALVES

The information formerly in this Appendix has been moved to Section XIII, Nonmandatory Appendix C.

**NONMANDATORY APPENDIX P
GUIDE TO THE RELOCATION OF OVERPRESSURE PROTECTION
REQUIREMENTS**

(23)

DELETED

ENDNOTES

- 1 In order to ensure that a finished head is not less than the minimum thickness required, it is customary to use a thicker plate to take care of possible thinning during the process of forming. The neck of an opening in a head with an integrally flanged opening will thin out due to the fluing operation. This is permissible, provided the neck thickness is not less than the minimum thickness specified in [HG-301](#) or the thickness required for a cylindrical shell having a diameter equal to the maximum diameter of the opening. (See [HG-323](#).)
- 2 The formulas provide safe construction as far as stress is concerned. Greater thicknesses may be necessary if deflection would cause leakage at threaded or gasketed joints.
- 3 The rules governing openings as given in this Code are based on the stress intensification created by the existence of a hole in an otherwise symmetrical section. They are based on experience with vessels designed with a safety factor of five applied to the specified minimum tensile strength of the shell material. External loadings such as those due to thermal expansion or to unsupported weight of connecting piping have not been evaluated. These factors should be given attention in unusual designs or under conditions of cyclic loading.
- 4 Typical examples of the application of these rules are given in [Nonmandatory Appendix D](#).
- 5 The opening made by a pipe or a circular nozzle, the axis of which is not perpendicular to the boiler wall or head, may be considered an elliptical opening for design purposes.
- 6 An obround opening is one that is formed by two parallel sides and semicircular ends.
- 7 Suggested installation practices for the secondary side of heat exchangers.
- 8 The foundry that casts the boiler parts or sections and that may shop assemble.
- 9 May be etched.
- 10 May be stamped.
- 11 See [HG-515.4](#) for additional requirements applicable to multiple, duplicate pressure vessel fabrication.
- 12 Examples of these nationally recognized standards are:
 American National Standard/CSA Standard Z21.13/CSA 4.9 for Gas-Fired Low Pressure Steam and Hot Water Boilers.
 American National Standard/CSA Standard Z21.17/CSA 2.7 for Domestic Gas Conversion Burners.
 American National Standard/ASME CSD-1, Controls and Safety Devices for Automatically Fired Boilers.
 National Fire Protection Association Code/NFPA 85, Boiler and Combustion Systems Hazards Code.
 Underwriters Laboratories, Inc., UL 296, Standards for Safety, Oil Burners.
 Underwriters Laboratories, Inc., UL 726, Standards for Safety, Oil Fired Boiler Assemblies.
 Underwriters Laboratories, Inc., UL 795, Standards for Safety, Commercial-Industrial Gas-Heating Equipment.
 Underwriters Laboratories, Inc., UL 834, Electric Heating, Water Supply and Power Boilers.
- 13 See [Nonmandatory Appendix H](#).
- 14 A certifying organization is one that provides uniform testing, examination, and listing procedures under established, nationally recognized standards and that is acceptable to the authorities having jurisdiction.
- 15 The top or side of the boiler shall mean the highest practicable part of the boiler proper but in no case shall the pressure relief valve be located below the normal operating level and in no case shall the pressure relief valve be located below the lowest permissible water level.
- 16 Guidance for the design of piping systems may be found in ASME B31.9, Building Services Piping.
- 17 Plumbing codes may require the installation of a reduced pressure principle backflow preventer on a boiler when the makeup water source is from a potable water supply.
- 18 These are pressure parts that comply with some ASME product standard accepted by reference in [Mandatory Appendix 2](#). The ASME product standard establishes the basis for the pressure-temperature rating and marking.
- 19 These are pressure parts that comply with an ASME product standard not referenced in [Mandatory Appendix 2](#), or in accordance with a parts Manufacturer's or the Boiler Manufacturer's standard that defines the pressure-temperature rating described in the part literature. The part literature shall specify, as a minimum, the material specification and pressure-temperature rating. The Manufacturer of the completed vessel shall satisfy him/ herself that all such parts used comply with the applicable rules of this Section and are suitable for the design conditions of the completed vessel.

- 20 Arc and gas welded pipe for use as the shell of a boiler shall be subject to the same requirements as a shell fabricated from plate, including inspection at the point of manufacture and Manufacturer's Partial Data Reports.
- 21 The pressure differential method is described in *Materials and Research Standards*, Vol. 1, No. 7, July 1961, published by ASTM.
- 22 These minimum thicknesses for pressure shall not be less than required by design formulas in [Part HG, Article 3](#), nor less than those thicknesses established by proof testing in [Part HG, Article 5](#).
- 23 It is not the intent of this paragraph to require measurement of reductions in thickness due to the welding process. If a disagreement between the Manufacturer and the Inspector exists as to the acceptability of any reduction in thickness, the depth shall be verified by actual measurement.
- 24 Flux residues can be extremely corrosive as well as interfere with visual inspection.
- 25 Example: If Class 20, Test Bar A, castings alone are being made, one test shall be made on each melt on Test Bar A. If Class 20, controlling sections A and B castings (that is, light and medium sections) are made from the same melt (or mixture), then Test Bars A and B shall be made and tested. In all cases, test bars corresponding to the different tensile classes (Nos. 20, 30, and 40) and controlling sections (A, B, and C) must be made and tested to correspond to the classes of iron specified for the castings, and the controlling sections thereof.
- 26 The use of ball and socket holders in the tensile strength test is recommended. Tests made under conditions where eccentric loadings may occur will give erroneous results.
- 27 The specified tensile strength is the tensile strength for the class of iron set forth in [Table HC-300](#).
- 28 In [Article 5](#), the Manufacturer referred to is the foundry who casts the boiler part or section and who may shop assemble it.
- 29 Military specification is available from Standardization Documents Order Desk, Building 4D, 700 Robbins Avenue, Philadelphia, PA 19111-5094.
- 30 Examples of these nationally recognized standards that are currently effective:
ANSI/UL 732, Standard for Oil-Fired Storage Tank Water Heaters.
American National Standard/CSA Standard ANSI Z21.10.3/CSA 4.3 for Gas Water Heaters, Volume III, Storage Water Heaters With Input Ratings Above 75,000 Btu Per Hour, Circulating and Instantaneous.
Underwriters Laboratories, Inc., UL 795, Standards for Safety, Commercial-Industrial Gas-Heating Equipment.
Underwriters Laboratories, Inc., UL 1453, Standards for Safety, Electric Booster and Commercial Storage Tank Water Heaters.

INTENTIONALLY LEFT BLANK

2023 ASME Boiler and Pressure Vessel Code

AN INTERNATIONAL CODE

The ASME Boiler and Pressure Vessel Code (BPVC) is a globally recognized and trusted source of technical requirements and guidance for the design, construction, and certification of boilers, pressure vessels, and nuclear components. With each new edition, the Code continues to evolve, introducing new technologies and processes to promote safety across pressure equipment applications and disciplines. Developed through a rigorous consensus process and fueled by the foresight of leading industry experts from around the world, the ASME BPVC is an ever-evolving set of standards that meets the needs of a changing world.

ASME provides BPVC users with an integrated suite of related offerings, which includes

- referenced standards
- related standards, reports, and guidelines
- conformity assessment programs
- conferences, seminars, and other events
- learning and development solutions
- ASME Press books and journals



For additional information and to order:

Phone: 1.800.THE.ASME

(1.800.843.2763)

Email: customercare@asme.org

Website: go.asme.org/bpvc

ISBN 978-0-7918-7578-0



9 780791 875780



4 0 0 0 4 0